

## FOREWORD

---

Welcome to the growing group of value-conscious people who drive Lexus vehicles. We are proud of the advanced engineering and quality construction of each vehicle we build.

This Owner's Manual explains the features of your new Lexus. Please read it and follow the instructions carefully so that you can enjoy many years of safe motoring.

When it comes to service, remember that your Lexus dealer knows your vehicle best and is interested in your complete satisfaction. Your Lexus dealer will provide quality maintenance and any other assistance you may require.

If there is not a Lexus dealer near you, or you need emergency assistance for any reason, please call the following number:

### U.S. OWNERS

- When traveling in the U.S. mainland or Canada:  
**Lexus Roadside Assistance 1-800-25-LEXUS (Toll-Free)**  
**(1-800-255-3987)**
- HAWAII:  
**Lexus Customer Service Assistance 1-800-25-LEXUS (Toll-Free)**  
**(1-800-255-3987)**

### CANADIAN OWNERS

- **Please refer to the separate "Owner's Guide" or "Owner's Manual Supplement".**

**Please leave this Owner's Manual in this vehicle at the time of resale. The next owner will need this information also.**

**All information and specifications in this manual are current at the time of printing. However, because of the Lexus policy of continual product improvement, we reserve the right to make changes at any time without notice.**

**Please note that this manual applies to all models and explains all equipment,**

**including options. Therefore, you may find some explanations for equipment not installed on your vehicle.**

**TOYOTA MOTOR CORPORATION**

## INTRODUCTION

---

### **New vehicle warranty**

Your new vehicle is covered by the following Lexus limited warranties:

- New vehicle warranty
- Emission control systems warranty
- Others

For further information, please refer to the separate "Owner's Guide", "Owner's Manual Supplement" or "Warranty Booklet".

### **Your responsibility for maintenance**

It is the owner's responsibility to make sure the specified maintenance is performed. Section 5 of this Owner's Manual gives details of these maintenance requirements. Included in Section 6 is general maintenance. For scheduled maintenance information, please refer to the separate "Owner's Manual Supplement/Maintenance Schedule".

### **Accessories, spare parts and modification of your Lexus**

A wide variety of non-genuine spare parts and accessories for Lexus vehicles are currently available in the market. You should know that Toyota does not warrant these products and is not responsible either for their performance, repair or replacement, or for any damage they may cause to, or adverse effect they may have on, your Lexus vehicle.

This vehicle should not be modified with non-genuine Lexus products. Modification with non-genuine Lexus products could affect its performance, safety or durability, and may even violate governmental regulations. In addition, damage or performance problems resulting from the modification may not be covered under warranty.

### **Spark ignition system of your Lexus**

The spark ignition system in your Lexus meets all requirements of the Canadian Interference-Causing Equipment Standard.

### **Installation of a mobile two-way radio system**

As the installation of a mobile two-way radio system in your vehicle could affect electronic systems such as the multiport fuel injection system/sequential multiport fuel injection system, cruise control system, anti-lock brake system and Supplemental Restraint System (SRS), be sure to check with your Lexus dealer for precautionary measures or special instructions regarding installation.

### **Scrapping of your Lexus**

The Supplemental Restraint System (SRS) in your Lexus consists of driver and front passenger airbags, side airbags and seat belt pretensioners. The SRS device contains explosive chemicals. If the vehicle is scrapped with the airbags and seat belt pretensioners left as they are, it may cause an accident such as a fire. Be sure to have the SRS removed and disposed of by a qualified service shop or by your Lexus dealer before you scrap your vehicle.

### **On-pavement and off-road driving tips**

This vehicle will handle and maneuver differently from an ordinary passenger car because it is also designed for off-road use. As with other vehicles of this type, failure to operate this vehicle correctly may result in loss of control or an accident. Be sure to read "Off-road vehicle precautions" on page 316 and "Off-road driving precautions" on page 320.

## HOW TO USE THIS MANUAL

---

### HOW TO USE THIS MANUAL

The contents of this manual are explained briefly on this page to help you make the best use of the manual. Please read this page and the rest of the Owner's Manual carefully to make sure you fully understand the operation of your vehicle.

This will help you enjoy safe and comfortable driving.

#### TABLE OF CONTENTS

The table of contents and the pictorial index provide easy reference to the appropriate pages.

#### BASIC OPERATION – QUICK REFERENCE

Operation of basic equipment is briefly explained in an easily understandable way for quick reference.

#### SECTION 1 – INSTRUMENTS AND CONTROLS

The vehicle's equipment is divided into the 7 groups listed below. Use of the equipment is explained, including any points you should pay particular attention to.

1. Keys and doors
2. Switches
3. Gauges, meters and service reminder indicators
4. Interior equipment
5. Exterior equipment

#### 6. Comfort adjustment

#### 7. Theft deterrent

#### SECTION 2 – AIR CONDITIONING AND AUDIO

The features of the vehicle's air conditioning and audio are explained in detail. Be sure to read this section so that you can make full use of them.

#### SECTION 3 – STARTING AND DRIVING

Starting the engine, driving, stopping, operation of features affecting vehicle handling, hints on vehicle safety and safe driving techniques are all explained. Please read everything in this section, and remember – drive safely!

#### SECTION 4 – IN CASE OF AN EMERGENCY

This section explains what to do in the event of an urgent situation such as the engine not starting or getting a flat tire, etc. If such a problem occurs, check the contents of this Owner's Manual and follow the instructions given.

#### SECTION 5 – MAINTENANCE

This section explains the importance of regular maintenance. Regular and periodic inspection and maintenance of your Lexus will help to keep your vehicle in its best condition.

#### SECTION 6 – SERVICE PROCEDURES AND SPECIFICATIONS

Simple maintenance procedure and service data are provided here for your reference should you wish to perform inspection

and maintenance yourself.

### **INDEX**

The page number is listed for each item in the Owner's Manual so that you can rapidly find the item and page you are searching for.

### **GAS STATION INFORMATION**

The information you need to know for appropriate servicing at the gas station is provided here.

### **QUICK INDEX**

This is designed so that you can quickly find the needed information when an urgent situation arises.

### **Safety symbol**

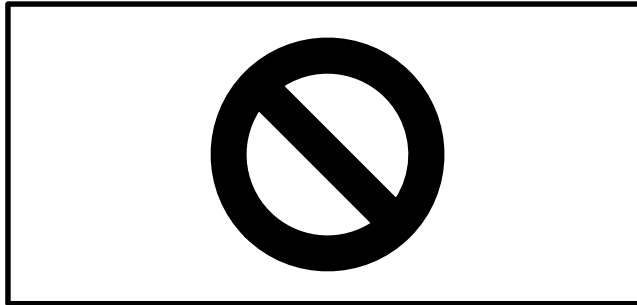

In this manual, you will also see a circle with a slash through it. This means "Do not", "Do not do this", or "Do not let this happen".

## HOW TO USE THIS MANUAL

---

### Safety and vehicle damage warnings

In this manual you will see CAUTION and NOTICE warnings. These are used in the following ways:



**This is a warning against something which may cause injury to people if the warning is ignored. You are informed what you must or must not do in order to avoid or reduce the risk to yourself and other people.**

### *NOTICE*

*This is a warning against something which may cause damage to the vehicle or its equipment if the warning is ignored. You are informed what you must or must not do in order to avoid or reduce the risk of damage to your Lexus and its equipment.*

**Your Lexus Owner's Manual provides you with a considerable amount of information. To use this information most effectively, please take the time to familiarize yourself with the contents and use of the manual.**





**PICTORIAL INDEX**

---

**INSTRUMENT PANEL**



## PICTORIAL INDEX

	<i>Page</i>		<i>Page</i>
<b>1</b> <i>Door lock switch and power window switches</i> .....	27, 41	<i>Clock</i> .....	76
<b>2</b> <i>Headlight, turn signal and fog light switch</i> .....	32	<i>Audio system</i> .....	237
<b>3</b> <i>Instrument panel light control</i> .....	69	<i>Automatic air conditioning controls</i> .....	221
<b>4</b> <i>Power rear view mirror control switch</i> .....	134	<b>13</b> <i>Car audio</i> .....	237
<b>5</b> <i>Theft deterrent system indicator light</i> .....	216	<b>14</b> <i>Front passenger's seat belt reminder light</i> .....	60
<b>6</b> <i>Driving position memory switch</i> .....	210	<b>15</b> <i>Automatic air conditioning controls</i> .....	221
<b>7</b> <i>Hood lock release lever</i> .....	103	<b>16</b> <i>Automatic transmission selector lever</i> .....	286
<b>8</b> <i>Parking brake</i> .....	283	<b>17</b> <i>Seat heater switch</i> .....	49
<b>9</b> <i>Wiper and washer switch</i> .....	37, 39	<b>18</b> <i>Traction control system off switch</i> .....	63
<b>10</b> <i>Cruise control switch</i> .....	299	<b>19</b> <i>Cigarette lighter</i> .....	80
<b>11</b> <i>Emergency flasher switch</i> .....	48	<b>20</b> <i>Driving pattern selector switch</i> .....	290
<b>12</b> <i>Multi-display</i>		<b>21</b> <i>Glove box/CD automatic changer</i> .....	84/258
<i>Cruise information display</i> .....	65		
<i>Outside temperature display</i> .....	80		

*For detailed information, refer to the description given in each section.*

**PICTORIAL INDEX**

---

**INSTRUMENT CLUSTER (Vehicles sold in U. S. A.)**



## PICTORIAL INDEX

	<i>Page</i>		<i>Page</i>
<b>1</b> <i>Traction control system off indicator/warning light</i> .....	63	<b>14</b> <i>Low fuel level warning light</i> .....	64
<b>2</b> <i>Slip indicator light</i> .....	303	<b>15</b> <i>Overdrive off indicator light</i> .....	289
<b>3</b> <i>Fuel gauge</i> .....	52	<b>16</b> <i>Snow mode indicator light</i> .....	290
<b>4</b> <i>Engine coolant temperature gauge</i> .....	54	<b>17</b> <i>Open door warning light</i> .....	63
<b>5</b> <i>Turn signal indicator light</i> .....	36	<b>18</b> <i>Driver's seat belt reminder light</i> .....	60
<b>6</b> <i>Automatic transmission indicator lights</i> .....	286	<b>19</b> <i>Brake system warning light</i> .....	59
<b>7</b> <i>Headlight indicator light</i> .....	32	<b>20</b> <i>SRS warning light</i> .....	61
<b>8</b> <i>Power mode indicator light</i> .....	290	<b>21</b> <i>Low oil pressure warning light</i> .....	62
<b>9</b> <i>ODO/TRIP knob</i> .....	56	<b>22</b> <i>Discharge warning light</i> .....	61
<b>10</b> <i>Odometer and trip meter</i> .....	56	<b>23</b> <i>Automatic transmission fluid temperature warning light</i> .....	63
<b>11</b> <i>Headlight high beam indicator light</i> .....	35	<b>24</b> <i>Low washer fluid warning light</i> .....	63
<b>12</b> <i>Tachometer</i> .....	55	<b>25</b> <i>Malfunction indicator lamp</i> .....	62
<b>13</b> <i>Cruise control indicator light</i> .....	299	<b>26</b> <i>Anti-lock brake system warning light</i> .....	62
		<b>27</b> <i>Rear light failure warning light</i> .....	63

*For detailed information, refer to the description given in each section.*

**PICTORIAL INDEX**

---

**INSTRUMENT CLUSTER (Vehicles sold in Canada)**



**PICTORIAL INDEX**

		<i>Page</i>			<i>Page</i>
1	<i>Traction control system off indicator/warning light</i>	63	14	<i>Low fuel level warning light</i>	64
2	<i>Slip indicator light</i>	303	15	<i>Overdrive off indicator light</i>	289
3	<i>Fuel gauge</i>	52	16	<i>Snow mode indicator light</i>	290
4	<i>Engine coolant temperature gauge</i>	54	17	<i>Open door warning light</i>	63
5	<i>Turn signal indicator light</i>	36	18	<i>Driver's seat belt reminder light</i>	60
6	<i>Automatic transmission indicator lights</i>	286	19	<i>Brake system warning light</i>	59
7	<i>Tail light indicator light</i>	32	20	<i>SRS warning light</i>	61
8	<i>Power mode indicator light</i>	290	21	<i>Low oil pressure warning light</i>	62
9	<i>ODO/TRIP knob</i>	56	22	<i>Discharge warning light</i>	61
10	<i>Odometer and trip meter</i>	56	23	<i>Automatic transmission fluid temperature warning light</i>	63
11	<i>Headlight high beam indicator light</i>	35	24	<i>Low washer fluid warning light</i>	63
12	<i>Tachometer</i>	55	25	<i>Malfunction indicator lamp</i>	62
13	<i>Cruise control indicator light</i>	299	26	<i>Anti-lock brake system warning light</i>	62
			27	<i>Rear light failure warning light</i>	63

*For detailed information, refer to the description given in each section.*

**PICTORIAL INDEX**

---

**SEAT AND STEERING WHEEL**

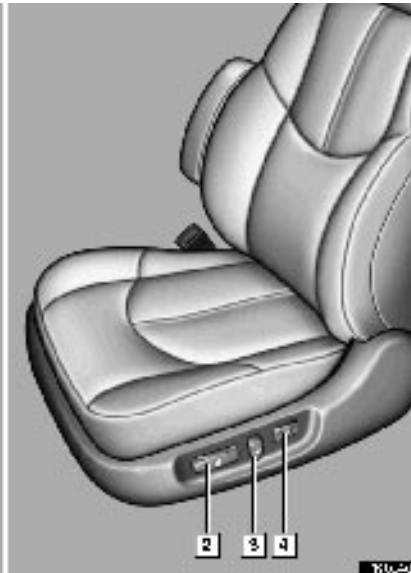

*Page*

- 1** *Tilt steering adjustment lever . . . . . 130*
- 2** *Seat position, seat cushion angle and height control switch . . . . . 116*
- 3** *Seatback angle control switch 116*
- 4** *Lumbar support control switch . . . . . 118*

*For detailed information, refer to the description given in each section.*

EXTERIOR VIEW

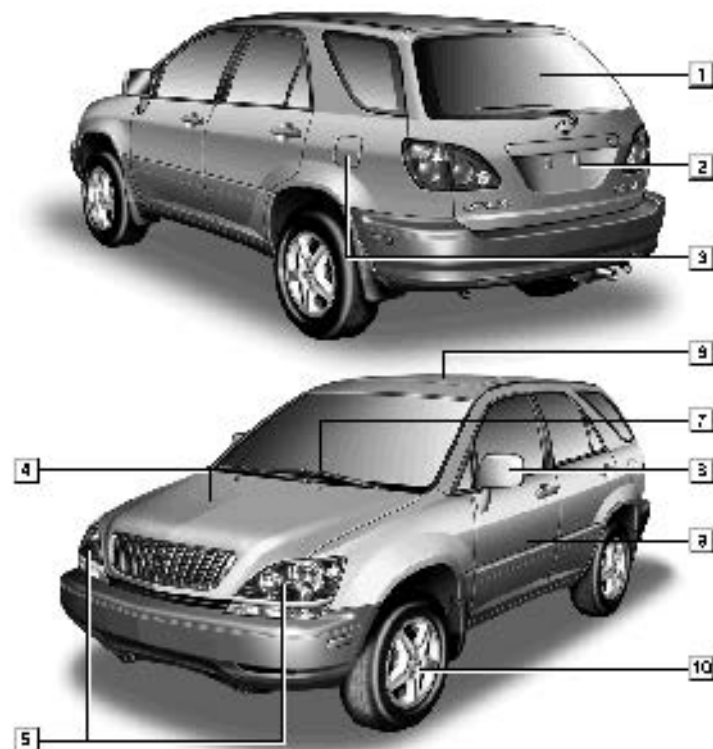

	<i>Page</i>
<b>1</b> Rear window defogger . . .	40
<b>2</b> Back door . . . . .	28
<b>3</b> Fuel filler door . . . . .	105
<b>4</b> Hood . . . . .	103
<b>5</b> Headlights . . . . .	32, 458
<b>6</b> Moon roof . . . . .	108
<b>7</b> Wiper and washer . . .	37, 458
<b>8</b> Outside rear view mirror	132
<b>9</b> Side door . . . . .	24
<b>10</b> Tire and wheel . . . . .	424

*For detailed information, refer to the description given in each section.*





## ***BASIC OPERATION***

---

### **QUICK REFERENCE**

Driver's seat .....	2
Steering wheel .....	2
Automatic transmission .....	3
Headlight and turn signal switch .....	4
Wiper switch .....	5

**BASIC OPERATION – QUICK REFERENCE**

**1. DRIVER'S SEAT**

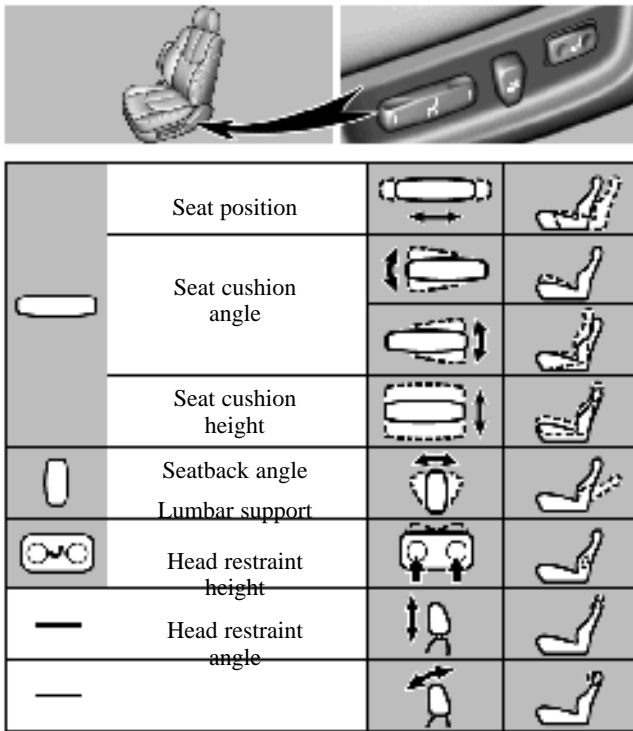

	Seat position		
	Seat cushion angle		
	Seat cushion height		
	Seatback angle		
	Lumbar support		
	Head restraint height		
	Head restraint angle		

E-001

**2. STEERING WHEEL**

**• TILT STEERING WHEEL**



To tilt the steering wheel up or down to the desired angle:

1. Pull the lever up while holding the steering wheel.
2. Push or pull the steering wheel to the desired angle.
3. Release the lever.

### 3. AUTOMATIC TRANSMISSION

**Lock release button (To prevent misshifting)**

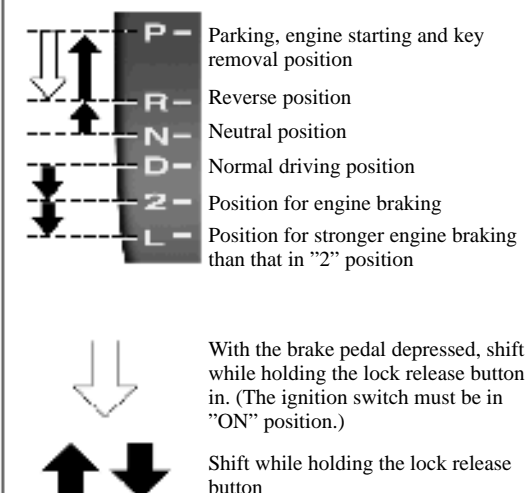

P - Parking, engine starting and key removal position

R - Reverse position

N - Neutral position

D - Normal driving position

2 - Position for engine braking

L - Position for stronger engine braking than that in "2" position

With the brake pedal depressed, shift while holding the lock release button in. (The ignition switch must be in "ON" position.)

Shift while holding the lock release button

**Overdrive switch**

For selecting either a three-speed or four-speed transmission

"ON" position (Shifting into overdrive possible)

"OFF" position (Shifting into overdrive not possible)

"O/D OFF" indicator light on the instrument cluster





Note: When the cruise control is being used, even if you downshift the transmission by turning off the overdrive switch, engine braking will not be applied because the cruise control is not cancelled. For the operation to decrease the vehicle speed, see page 302.

**BASIC OPERATION – QUICK REFERENCE**



**4. HEADLIGHT AND TURN SIGNAL SWITCH**

**● HEADLIGHT SWITCH**

**With the ignition OFF**



	Parking, tail, license plate, side marker and instrument panel lights turn on.
	Headlights also turn on.
	Automatic light control

**With the engine started and parking brake released**

	Parking, tail, license plate, side marker and instrument panel lights turn on.
	Headlights turn of at full intensity.
	Automatic light control

	High beam
	Headlight flasher

**● TURN SIGNAL SWITCH**

	Right or left turn
	Lane change (Right or left)

## 5. WIPER SWITCH

### ● Front



Intermittent operation



- 1 Low speed operation
- 2 High speed operation



Washer on

### ● Rear

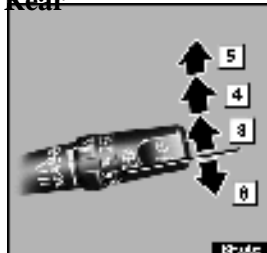

3 Wiper on (Intermittent operation)

4 Wiper on (Normal operation)

5 Washer also on

6 Washer on



# *SECTION 1 - 1*

---

## **INSTRUMENTS AND CONTROLS**

### **Keys and doors**

Keys .....	8
Engine immobiliser system .....	12
Wireless remote control .....	15
Side doors .....	24
Back door .....	28



## KEYS AND DOORS

---

### KEYS



- 1** Master key (black) – The master key works in every lock. For your Lexus dealer to make you a new key with built-in transponder chip, your dealer will need it.
- 2** Sub key (gray) – The sub key will not open the glove box.
- 3** Key number plate – Keep the plate in a safe place such as your wallet, not in the vehicle.

The master key and sub key each have a transponder chip in their key head which is very important for the immobiliser system function, so be careful not to lose these keys. If you make your own duplicate key, you will not be able to cancel the system or start the engine.

To protect things locked in the glove box when you have your vehicle parked, leave the sub key with the attendant.

Since the doors can be locked without a key, you should always carry a spare master key in case you accidentally lock your keys inside the vehicle.

If you should lose your keys or if you need additional keys, duplicates can be made by a Lexus dealer using the key number.

We recommend you to write down the key number and keep it in safe place.



Since a transponder chip is not built in this flat key, you cannot start the engine with this key. Use this key to release the lock in case you accidentally lock your keys inside the vehicle or trunk.

Insert your flat key in its key case as shown. We recommend that you always carry this with you for emergency use. Do not leave it in your vehicle.

**NOTICE**

- *Do not let the key case become bent as the key may fall out or become bent also.*
- *The flat key is designed for emergency use only.*

## KEYS AND DOORS

---



### ***NOTICE***

*When using a key containing a transponder chip, observe the following precautions:*

- *When starting the engine, do not use the key with a key ring resting on the key grip and do not press the key ring against the key grip. Otherwise the engine may not start, or may stop soon after it starts.*



- *When starting the engine, do not use the key with other transponder keys around (including keys of other vehicles) and do not press other key plates against the key grip. Otherwise the engine may not start, or may stop soon after it starts. If this happens, remove the key once and then insert it again after taking off other transponder keys (including keys of other vehicles) from the ring or while gripping or covering them with your hand to start the engine.*

## KEYS AND DOORS

---



- *Do not bend the key grip.*
- *Do not cover the key grip with any material that cuts off electromagnetic waves.*
- *Do not knock the key hard against other objects.*
- *Do not leave the key exposed to high temperatures for a long period, such as on the dashboard and hood under the direct sunlight.*
- *Do not put the key in water or wash it in an ultrasonic washer.*
- *Do not use the key with electromagnetic materials.*

## ENGINE IMMOBILISER SYSTEM



**The engine immobiliser system is a theft prevention system. When you insert the key in the ignition switch, the transponder chip in the key's head transmits an electronic code to the vehicle. The engine will start, only when the electronic code in the chip corresponds to the registered ID code for the vehicle.**

The system is automatically set when the key is removed from the ignition switch. At this time, the "SECURITY" indicator light at the bottom of the instrument cluster flashes. When you insert the key in the ignition switch, the "SECURITY" indicator light goes out and the system is canceled automatically, which enables the engine to start.

For your Lexus dealer to make you a new key with built-in transponder chip, your dealer will need your key number and master key. However, there is a limit to the number of additional keys your Lexus dealer can make for you.

**If you make your own duplicate key, you will not be able to cancel the system or start the engine.**

## KEYS AND DOORS

---

**For vehicles sold in U.S.A.**

**FCC ID: NI4TMIM-3  
MADE IN JAPAN**

This device complies with Part 15 of the FCC Rules.  
Operation is subject to the following two conditions:  
(1) This device may not cause harmful interference,  
and (2) this device must accept any interference  
received, including interference that may cause  
undesired operation.



**CAUTION**

**Changes or modifications not expressly approved by the party  
responsible for compliance could void the user's authority to  
operate the equipment.**

**For vehicles sold in Canada**

This device complies with RSS-210 of Industry Canada.  
Operation is subject to the following two conditions:  
(1) this device may not cause interference, and (2)  
this device must accept any interference, including  
interference that may cause undesired operation of  
the device.

**WIRELESS REMOTE  
CONTROL\***



## KEYS AND DOORS

---



- 1** Locking the doors
- 2** Unlocking the doors
- 3** Indicator light
- 4** Sounding an alarm

*NOTE: \*This feature can be set inoperative as vehicle theft deterrent measure in case of the loss of the wireless remote control key. Ask your Lexus dealer for details.*

When you operate any button on the key, push it slowly and surely.

The operational range of the wireless remote control is approximately 1 meter (3 ft.). The effective range may vary with different conditions. To activate the wireless remote control without fail, do it approximately 1 meter (3 ft.) from your Lexus.

In the following cases, the battery in the key may be discharged. If this is a case, replace it using a special screwdriver.

- The remote control does not work.
- The operational range of wireless remote control becomes extremely short.
- The indicator light on the key is dimmed or does not come on.

For the replacement of the battery, see "Replacing the battery" on page 21. You can also have the battery of the key replaced by your Lexus dealer.

If you lose the wireless key, contact your Lexus dealer as soon as possible to avoid the possibility of theft, or an accident.

You can use up to 4 wireless remote control keys for the same vehicle. Contact your Lexus dealer for detailed information.

**The wireless remote control key is an electronic component. Observe the following instructions in order not to cause damage to the key.**

- Do not leave the wireless remote control key on places where the temperature becomes high such as on the dashboard.
- Do not disassemble it.
- Avoid knocking it hard against other objects or dropping it.
- Avoid putting it in water.

### Locking/Unlocking the doors

**When you push the "LOCK" button on the key briefly, all the side doors and back door can be locked from outside the vehicle.**

At this time, you can hear one beep\* and the turn signal lights flash.\*\* However, when you push the "LOCK" button with any door not closed securely, the buzzer sounds for 10 seconds.\*\*\* To stop the buzzer, close all the side doors and back door securely or push the "UNLOCK" button. If the key is in the ignition switch, locking cannot be done.

Make sure all the doors are locked when you leave the vehicle. Push the "LOCK" button once again. If they were already locked, the turn signal lights will flash.

*NOTE: \*The volume of beep sound can be changed.  
\*\*The turn signal lights can be set not to flash. \*\*\*The buzzer can be set not to sound with any door not closed securely. Ask your Lexus dealer for details.*

**When you push the "UNLOCK" button, the driver's door is unlocked. Pushing that button once again within 3 seconds from the first push, all other side doors and back door are also unlocked.\***

*NOTE: \*Unlocking by a 2-time operation can be changed. Ask your Lexus dealer for details.*

## KEYS AND DOORS

---

At this time, two beeps sound.\* Together with the activation of unlocking, the interior light comes on for 15 seconds if the interior light switch is in "DOOR" position.\*\* However, this function does not work when the ignition key is in the "ON" position. For further information, see "Interior lights" on page 73.

You have 30 seconds to open a door after using the wireless remote unlock feature.\*\*\* If a door is not opened by then, all the doors will be automatically locked again.

Even if the "LOCK" or "UNLOCK" button is kept pressed in, the locking or unlocking operation is not repeated. Release the button and then push again.

*NOTE: \*The volume of beep sound can be changed.  
\*\*The interior light can be set not to come on or the duration of lighting can be changed. \*\*\*The time before automatic re-locking can be changed. Ask your Lexus dealer for details.*

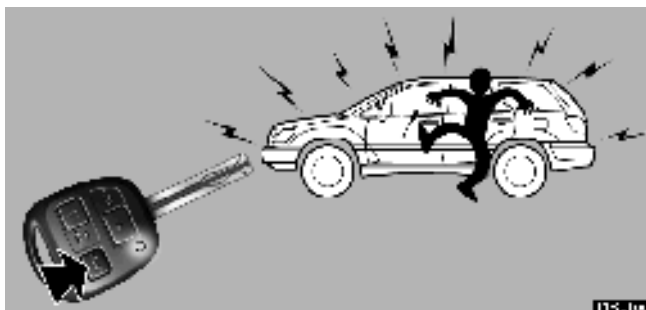

### Sounding an alarm\*

**When you push the "PANIC" button for about 1 second, an alarm sounds to deter any person trying to break into or damage your vehicle.**

If you want to stop the alarm, push any button.

This function does not work when the ignition key is in the "ON" position.

*NOTE: \*The alarm can be set not to sound. Ask your Lexus dealer for details.*



Push the "UNLOCK" button until the windows and moon roof start to move. A beep sounds just before opening. When you release the button, the windows and moon roof stop opening.

### **Operating the windows and moon roof**

**The windows and moon roof can be opened using a wireless key from outside the vehicle.\***

*NOTE: \*The windows can be set inoperative. The moon roof can be set to slide open, tilt up or inoperative. Ask your Lexus dealer for details.*

**For vehicles sold in U.S.A.**

**FCC ID: NI4TMRX-1  
MADE IN JAPAN**

This equipment has been tested and found to comply with the limits for a Class B digital device, pursuant to Part 15 of the FCC Rules. These limits are designed to provide reasonable protection against harmful interference in a residential installation. This equipment generates, uses and can radiate radio frequency energy and, if not installed and used in

## KEYS AND DOORS

---

accordance with the instructions, may cause harmful interference to radio communications. However, there is no guarantee that interference will not occur in a particular installation. If this equipment does cause harmful interference to radio or television reception, which can be determined by turning the equipment off and on, the user is encouraged to try to correct the interference by one or more of the following measures:

- Reorient or relocate the receiving antenna.
- Increase the separation between the equipment and receiver.
- Connect the equipment into an outlet on a circuit different from that to which the receiver is connected.
- Consult the dealer or an experienced radio / TV technician for help.



### CAUTION

**Changes or modifications not expressly approved by the party responsible for compliance could void the user's authority to operate the equipment.**

**FCC ID: NI4TMTX-1  
MADE IN JAPAN**

**FCC ID: NI4TMRX-1  
MADE IN JAPAN**

This device complies with Part 15 of the FCC Rules. Operation is subject to the following two conditions: (1) This device may not cause harmful interference, and (2) this device must accept any interference received, including interference that may cause undesired operation.

**For vehicles sold in Canada**

This device complies with RSS-210 of Industry Canada.  
Operation is subject to the following two conditions:  
(1) this device may not cause interference, and (2) this device must accept any interference, including interference that may cause undesired operation of the device.

**Replacing the battery**

When you replace the battery, prepare a lithium battery CR1616 and a special screwdriver.

## KEYS AND DOORS

---



### CAUTION

Special care should be taken that small children do not swallow the removed battery or components.

### NOTICE

*When replacing the battery, be careful not lose the components, screws and O-ring.*



1. Remove the screw, and then the cover while pushing it in the arrow direction.

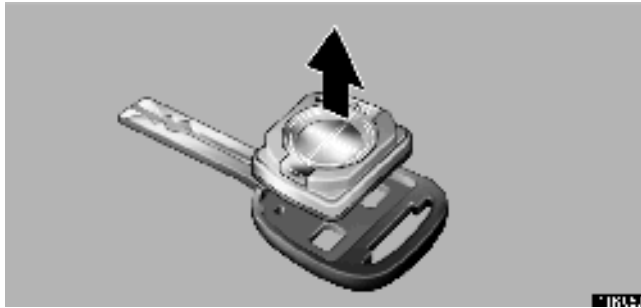

2. Remove the module from the key frame.

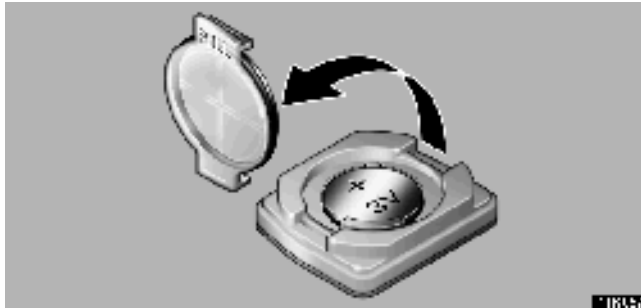

3. Remove the lid of the module.

4. Take out the discharged battery and put a new battery with the positive side up.



## KEYS AND DOORS

---

### **NOTICE**

- *Make sure the positive side and negative side of the battery should be faced correctly.*
- *Be careful not to bend the electrode of the battery insertion and that dust or oils do not adhere to the inside of the module.*
- *Take care not to lose the screws and O-ring.*

5. Install the lid.

### **NOTICE**

*Take care not to damage or bend the O-ring when installing.*

6. Install the module into the key frame and secure the cover with the screw.

7. When pushing any switch on the wireless key, make sure the indicator light comes on.

## SIDE DOORS

### Locking with key



► **1** Lock **2** Unlock

**Turn the key towards the front of the vehicle to lock and towards the back to unlock.**

All the side doors and back door lock and unlock simultaneously with either front door. In the driver's door lock, turning the key once will unlock the driver's door and twice in succession will unlock all the side doors and back door simultaneously.\* In the passenger's door lock, turning the key once will unlock all the side doors and back door simultaneously.

*NOTE: \*Unlocking by a 2-time operation can be changed. Ask your Lexus dealer for details.*

The windows and moon roof can be opened and closed from outside the vehicle using the key. For details, see "Power window switches" on page 41 and "Moon roof" on page 108.

## KEYS AND DOORS

---

### Locking with inside lock knob

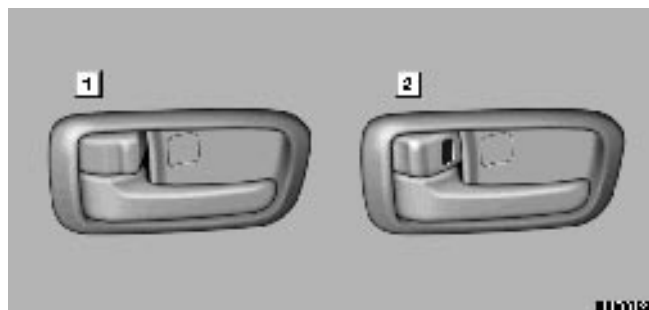

► **1** Lock **2** Unlock

**Push the knob forward to lock and pull the knob backward to unlock.**

When locked, the door cannot be opened with either the outside or inside door handle.

Closing the door with the lock button pushed in will also lock the door. Be careful not to lock your keys in the vehicle. With the key in the ignition switch and the door open, the lock knob cannot be moved in the lock position.



**CAUTION**

Before driving, make sure the doors are closed and locked, especially when small children are in the vehicle. Along with the proper use of seat belts, locking the doors helps prevent the driver and passengers from being thrown out from the vehicle during an accident. It also helps prevent the doors from being opened unintentionally.

**Locking with power door lock switch**



► **1** Lock **2** Unlock

To lock all the doors simultaneously, push the power door lock switch on the front side. Pushing on the rear side will unlock them.

The same switch is also equipped on the front passenger's side.

## KEYS AND DOORS

---

### Locking with rear door child-protector



► **1** Lock **2** Unlock

Whenever small children are in the vehicle, lock the rear door so that it does not open from the inside. To do this, move the knob to the lock position as shown on the label next to the knob.



## BACK DOOR

Locking and unlocking with key

► **1 Lock 2 Unlock 3 Open**

**Insert the master key into the keyhole and turn it.**

To lock: Turn the key clockwise.

To unlock: Turn the key counterclockwise.

The back door can be locked and unlocked together with the side doors by means of the power door lock system. (For instructions, see "Locking with power door lock switch" on page 27.)

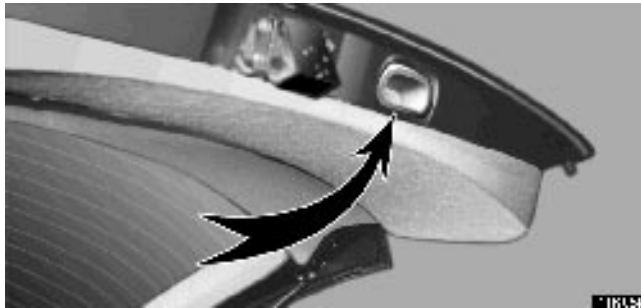

**When closing the back door, use the inside handle for easier reach to the back door.**

To close the back door, lower it and press down on it. After closing the back door, try pulling it up to make sure it is securely closed.

See "Luggage stowage precautions" on page 100 for precautions to observe in loading luggage.

## KEYS AND DOORS

---



### CAUTION

- Keep the back door closed while driving. This not only keeps the luggage from being thrown out but also prevents exhaust gases from entering the vehicle.
- If the open back door hides the rear stop and tail lights or rear turn signal lights while you are parked, other road users must be warned of the presence of your vehicle by a warning triangle or other device.

### NOTICE

*To prevent damage to the back door dampers, do not apply any force, paint or let any other foreign matter on them.*

# *SECTION 1 - 2*

---

## **INSTRUMENTS AND CONTROLS**

### **Switches**

Headlight switch .....	32
Headlight dimmer and turn signal switch .....	35
Fog light switch .....	37
Wiper and washer switch .....	37
Rear window wiper and washer switch .....	39
Rear window and outside rear view mirror defogger switch .....	40
Power window switches .....	41
Emergency flasher switch .....	48
Seat heater switch .....	49



## SWITCHES

---

### HEADLIGHT SWITCH

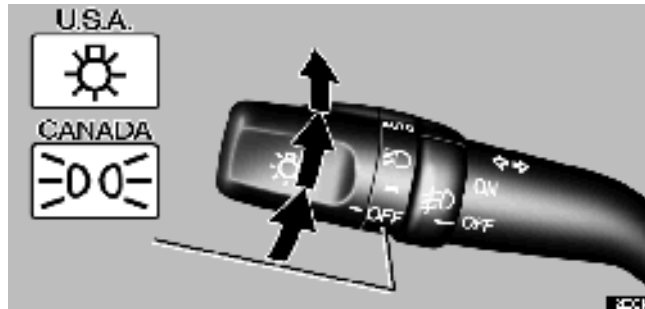

**To turn the lights on, twist the knob on the end of the lever.**

**FIRST CLICKSTOP:** Only the parking, tail, license plate, side marker and instrument panel lights turn on.

**SECOND CLICKSTOP:** Headlights also turn on.

**THIRD CLICKSTOP ("AUTO"):** The headlights and all other lights automatically turn on depending on the darkness of the surroundings.\*

**Vehicles sold in U.S.A.:** When the headlights are on, the headlight indicator lights up in the instrument cluster.

**Vehicles sold in Canada:** When the tail lights are on, the tail light indicator lights up in the instrument cluster.

**Manually twist the knob to the second clickstop to turn on the headlights if they are needed immediately when entering a dark tunnel, parking structure, etc.**

When the headlight switch is turned to the first or second clickstop, the brightness of the instrument cluster will be reduced slightly unless the instrument panel light control knob is turned fully on.

*NOTE: \*The operating condition or sensitivity can be changed. Ask your Lexus dealer for details.*

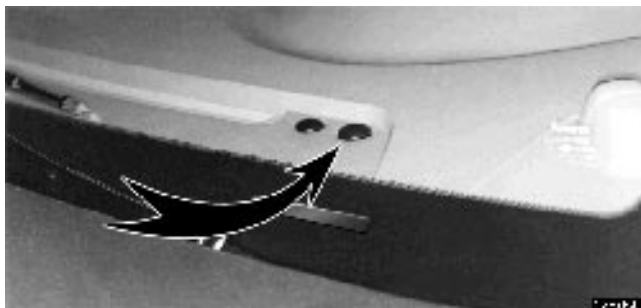

The automatic light control sensor is on top of the driver's side instrument panel.

Do not place anything on the instrument panel, and/or do not affix anything on the windshield to block this sensor.

When the headlights come on, the lights automatically turn off about 30 seconds after any of the doors is opened and closed with the ignition key turned to the "ACC" or "LOCK" position.\* To turn them on again, turn the ignition key to the "ON" position, or turn the headlight switch off and then twist the knob until the first or second clickstop. If you are going to park for over one week, make sure the headlight switch is off.

When the headlight switch is on with all the doors locked, pushing the "LOCK" button on the wireless remote control key turns off the headlights.

*NOTE: \*The time before turning off the lights can be changed. Ask your Lexus dealer for details.*

### **Daytime Running Light System**

The headlights turn on at reduced intensity when the parking brake is released with the engine started, even with the light switch in the "OFF" position. They will not go off until the

## SWITCHES

---

ignition switch is turned off.

To turn on the other exterior lights and instrument panel lights, twist the knob to the first clickstop.

Twist the knob to the second clickstop to turn on the headlights to full intensity for driving at night.

When setting the knob to the third clickstop ("AUTO"), the headlights will automatically adjust to full intensity and/or turn on the other lights depending on the darkness of the surroundings. Likewise, as the surroundings become brighter, the headlights will turn to reduced intensity, ultimately turning off the other lights.

### ***NOTICE***

***To prevent the battery from being discharged, do not leave the lights on longer than necessary when the engine is not running.***

## HEADLIGHT DIMMER AND TURN SIGNAL SWITCH



**For high beam, push the lever forward. Pull it back for low beam. For the headlight flasher, pull it further back.**

A blue light in the instrument cluster indicates high beam or headlight flasher is on.

The headlight flasher works even when the headlight switch is off.

## SWITCHES

---



**For signaling turns, move the lever up or down in the conventional manner.**

The ignition key must be in the "ON" position.

The turn signal is self-cancelling after a turn, but after a lane change, you may have to cancel it by hand. You can also signal a lane change by moving the turn signal lever partway and holding it there.

If the green light in the instrument cluster flashes faster than normal, it indicates that the front or rear turn signal bulb has burned out. If this indicator light does not come on, the fuse or the indicator light itself has probably failed.

### FOG LIGHT SWITCH

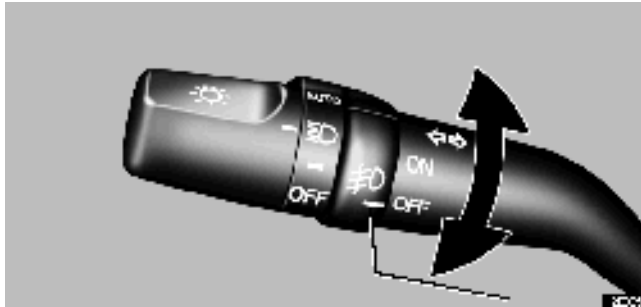

To turn on the fog lights, turn the switch to the "ON" position. The fog lights come on only when the headlights are on low beam.

### WIPER AND WASHER SWITCH

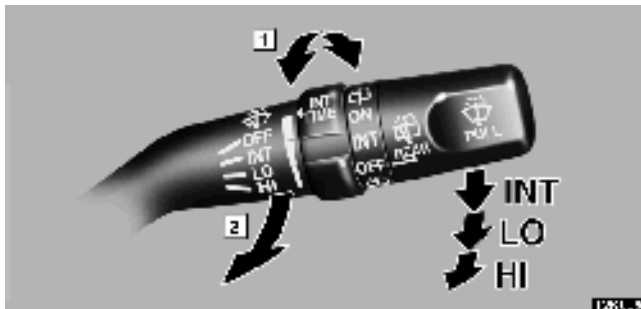

## SWITCHES

---

► **1** *Interval adjuster*   **2** *Washer on*

**To turn the wipers on, move the lever down until you reach the desired speed setting.**

The ignition key must be in the "ON" position.

**There are 3 settings:**

**"INT" position:** Intermittent operation

**"LO" position:** Low speed operation

**"HI" position:** High speed operation

**Twist the interval adjuster upward to increase the wiping time interval between sweeps, and downward to decrease it.**

The wiper lever must be in the "INT" position.

**To make the washer squirt, pull the lever toward you and release it.**

Also, the wipers will automatically operate a couple of times after the washer squirts even with the lever in the "OFF" position.

The low washer fluid warning light in the instrument cluster comes on when the fluid level in the tank becomes nearly empty. For information on adding washer fluid, see "Adding washer fluid" on page 458.

In cold weather, warm the windshield with the defroster before using the washer. This will help prevent icing, which could block your vision.

***NOTICE***

***Do not operate the wipers if the windshield is dry. It may scratch the glass.***

## REAR WINDOW WIPER AND WASHER SWITCH



- **1** Washer on during wiping    **2** Washer on

**To turn the wipers on, twist the knob at the end of the lever.**

The ignition key must be in the "ON" position.

**There are 2 settings:**

**"INT" position:** Intermittent operation

**"ON" position:** Low speed operation

**To make the washer squirt, twist the knob downward to position 2.**

**To make the washer squirt while operating in "ON" position, twist the knob upward to position 1.**

The knob automatically returns from these positions after you release it.

The low washer fluid warning light in the instrument cluster comes on when the fluid level in the tank becomes nearly empty. For information on adding washer fluid, see "Adding washer fluid" on page 458.

### **NOTICE**

*Do not operate the rear window wiper if the rear window is dry. It may scratch the glass.*



## SWITCHES

---

### REAR WINDOW AND OUTSIDE REAR VIEW MIRROR DEFOGGER SWITCH



**To turn the electric rear window and outside rear view mirror defogger on, push the switch.**

The ignition key must be in the "ON" position.

The thin heater wires on the inside of the rear window and the heater panels in the outside rear view mirrors will quickly clear the surface. An indicator light is on when the defogger is operating.

The system will automatically shut off when the defogger has operated about 15 minutes.

**CAUTION**

**Since the mirror surfaces can get hot, keep your hands off them when the rear window and outside rear view mirror defogger switch is on.**

If further defrosting or defogging is desired, simply actuate the switch again. When the surface has cleared, push the switch once again to turn the defogger off. Continuous use may cause the battery to discharge, especially during stop-and-go driving. The rear window defogger is not designed to dry rain water or to melt snow.

If the outside rear view mirrors are heavily coated with ice, use a spray de-icer before operating the switch.

**NOTICE**

- *When cleaning the inside of the rear window, be careful not to scratch or damage the heater wires.*
- *To prevent the battery from being discharged, do not operate the defogger continuously longer than necessary.*

**POWER WINDOW SWITCHES**

## SWITCHES

---

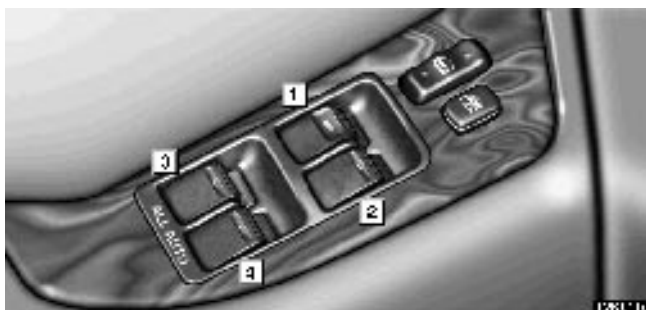

- ▶ **1** For driver's window
- 2** For front passenger's window
- 3** For left rear window
- 4** For right rear window

**To raise or lower the windows, use the switch on each door. The passengers' windows can also be controlled by the switches on the driver's door.**

The power windows work when the ignition key is in the "ON" position.

**Key off operation:** Even if the ignition key is turned to the "ACC" or "LOCK" position, the window can be operated until any of the doors is opened (or for about 45 seconds).

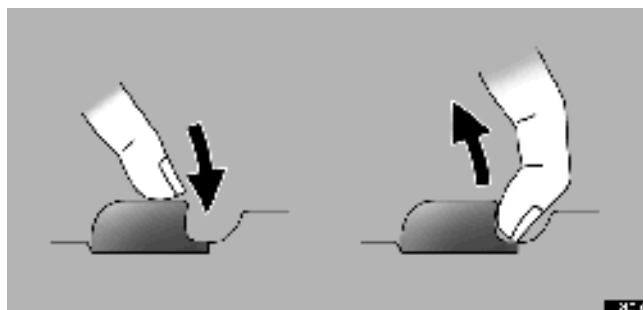

**Operating the switches**

**To raise or lower the window, pull the switch halfway up or push it halfway down.**

**Automatic operation:** To fully raise or lower the window automatically, pull the switch fully up or push it fully down.

To stop the window partway, lightly push or pull the switch in the opposite direction and then release it.

**Operating the window lock switch**

## SWITCHES

---



### ►Indicator light

With the window lock switch pressed in, only the driver's window can be raised or lowered.

The indicator lights on the switch tell you which of the switches can be operated.

### Operating the windows from outside the vehicle

(a) The windows can be opened and closed using an ignition key.\*

*NOTE: \*This feature can be set inoperative. Ask your Lexus dealer for details.*

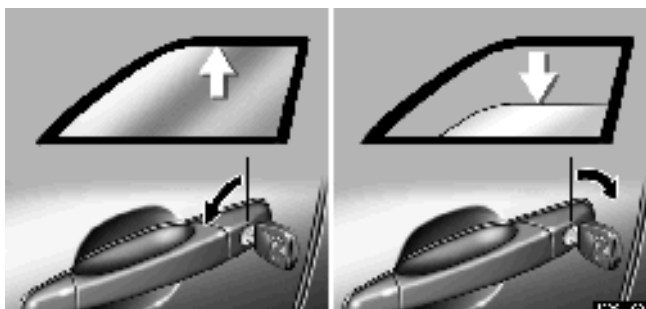

## SWITCHES

---

**Insert the ignition key into the key hole on the driver's side.**

**To close the windows:** Turn the key in the locking direction and hold it.

After the door is locked, the window begins to close. To stop in the middle, return the key.

**To open the windows:** Turn the key in the unlocking direction and hold it.

After the door is unlocked, the window begins to open. To stop in the middle, return the key.

**(b) The windows can be opened using a wireless remote control key.**

**Push and hold the "UNLOCK" button. When you release the button, the windows stop opening.**

## **SWITCHES**

---

### **Jam protection function**

During automatic raising operation, key off raising operation or raising operation using the ignition key from the outside, the window stops and is lowered if something gets caught between the window and window frame.

If an impact is given to the window, this function may work without anything caught.



**CAUTION**

- Never try jamming any part of your body to make the jam protection function work intentionally.
- The jam protection function may not work when something gets caught just before the window fully closed.



**CAUTION**

To avoid serious personal injury, you must do the following.

- Always make sure the head, hands and other parts of the body of all occupants are kept completely inside the vehicle before you close the power windows. If someone's neck, head or hands gets caught in a closing window, it could result in a serious injury. When anyone closes the power windows, be sure that they operate the windows safely.
- When small children are in the vehicle, never let them use the power window switches without supervision. Use the window lock switch to prevent them from making unexpected use of the switches.
- Never leave small children alone in the vehicle, especially with the ignition key still inserted. They could use the power window switches and get trapped in a window. Unattended children can become involved in serious accidents.



## SWITCHES

---

### EMERGENCY FLASHER SWITCH



**To turn on the emergency flashers, push the switch. Push the switch again to turn them off.**

All the turn signal lights will flash. The emergency flashers will work with the engine running or off and with or without the ignition key.

Turn on the emergency flashers to warn other drivers if you must stop your vehicle where it might be a traffic hazard.

Always pull your vehicle as far off the road as possible.

The turn signal light switch will not work when the emergency flashers are in operation.

#### ***NOTICE***

***To prevent the battery from being discharged, do not leave the switch on longer than necessary when the engine is not running.***

## SEAT HEATER SWITCH

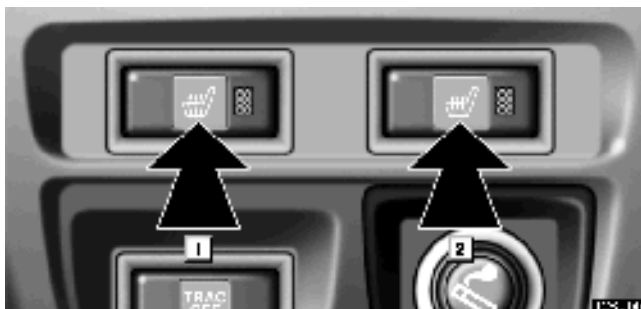

- ▶ **1** *For driver's seat*
- 2** *For front passenger's seats*

To turn on the seat heater, push the switch. To turn off, push the switch again.

The ignition key must be in the "ON" position.



### CAUTION

Occupants must use caution when operating the seat heater because they may experience minor burns even at low temperatures. Use extra caution for;

- Baby, small child, elderly person, sick person or handicapped person

## SWITCHES

---

- Persons who have delicate skin
  - Persons who are exhausted
  - Persons who have taken alcohol or drugs which induce sleep (sleeping drug, cold remedy, etc.).
- To prevent the seat from overheating, do not use the seat heater with a blanket, cushion, or other insulating objects which cover the seat.

### *NOTICE*

- *Do not put unevenly weighted objects on the seat and do not stick sharp objects (needles, nails, etc.) into the seat.*
- *When cleaning the seats, do not use organic substances (paint thinner, benzine, alcohol, gasoline, etc.). They may damage the heater and seat surface.*
- *To prevent the battery from being discharging, turn the switches on when the engine is running.*

# *SECTION 1 - 3*

---

## **INSTRUMENTS AND CONTROLS**

### **Gauges, meters and service reminder indicators**

Fuel gauge .....	52
Engine coolant temperature gauge .....	54
Tachometer .....	55
Odometer and trip meter .....	56
Service reminder indicators and warning buzzers .....	57
Cruise information display .....	65
Instrument panel light control .....	69

## GAUGES, METERS AND SERVICE REMINDER INDICATORS

---

### FUEL GAUGE



### ► *Low fuel level warning light*

**The gauge is displayed when the ignition switch is on and indicates the approximate quantity of fuel remaining in the tank.**

It is a good idea to keep the tank over 1/4 full.

If the fuel level approaches "E" or the low fuel level warning light comes on, fill the fuel tank as soon as possible.

On inclines or curves, due to the movement of fuel in the tank, the fuel gauge needle may fluctuate or the low fuel level warning light may come on earlier than usual.

If the fuel tank is completely empty, the malfunction indicator lamp comes on. Fill the fuel tank immediately.

The indicator lamp goes off after driving several times. If the indicator lamp does not go off, contact your Lexus dealer as soon as possible.

See the inner back cover for fuel capacity and recommended fuel selection.

**GAUGES, METERS AND SERVICE REMINDER INDICATORS**

---

**ENGINE COOLANT  
TEMPERATURE GAUGE**

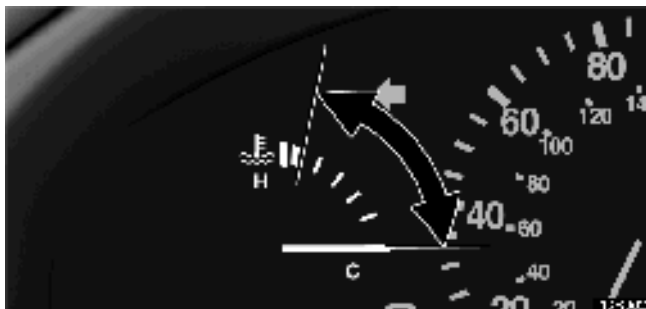

► *Normal range*

The gauge indicates the engine coolant temperature when the ignition switch is on. The engine operating temperature will vary with changes in weather and engine load.

If the needle points to the red zone or higher, stop your vehicle and allow the engine to cool.

Your vehicle may overheat during severe operating conditions, such as:

- Driving up a long hill on a hot day.
- Reducing speed or stopping after high speed driving.
- Idling for a long period with the air conditioning on in stop-and-go traffic.
- Towing a trailer.

## TACHOMETER

**NOTICE**

- *Do not remove the thermostat in the engine cooling system as this may cause the engine to overheat. The thermostat is designed to control the flow of coolant to keep the temperature of the engine within the specified operating range.*
- *Do not continue driving with an overheated engine. See "If your vehicle overheats" on page 343.*





## GAUGES, METERS AND SERVICE REMINDER INDICATORS

---

The tachometer indicates engine speed in thousands of rpm (revolutions per minute). Use it while driving to prevent engine overrevving.

Driving with the engine running too fast causes excessive engine wear and poor fuel economy. Remember, in most cases the slower the engine speed, the greater the fuel economy.

### ***NOTICE***

*Do not let the indicator needle get into the red zone. This may cause severe engine damage.*

## ODOMETER AND TRIP METER



► **”ODO/TRIP” knob**

This meter displays the odometer and two trip meters. To change the mode indication, push the ”ODO/TRIP” knob briefly. Each time you push the knob, the mode changes in order from the odometer to trip meter A to trip meter B, then back to the odometer, etc.

The odometer records the total distance the vehicle has been driven. The twin trip meter records two different distances independently.

For example, you can use one meter to calculate the fuel economy and the other to measure the distance on each trip.

**To set the A trip meter to zero, display the A meter reading, push the knob and hold it. The same applies for the B trip meter.**



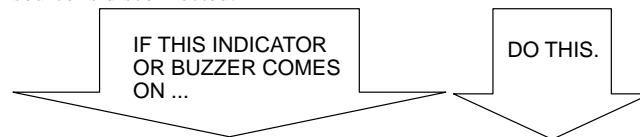





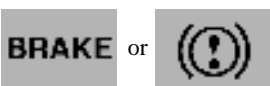

The data of trip meters will be cancelled if the electrical power source is disconnected.

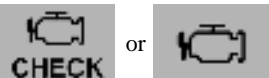
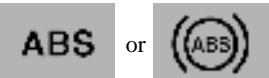
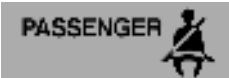

## SERVICE REMINDER INDICATORS AND WARNING BUZZERS

## GAUGES, METERS AND SERVICE REMINDER INDICATORS

---

- |     |   |   |     |   |                               |
|-----|---|---|-----|---|-------------------------------|
| (a) |  | If parking brake is off, stop and check.  | (f) |    | Stop and check.               |
| (b) |  | Fasten driver's seat belt.                | (g) |    | Take vehicle to Lexus dealer. |
|     | (Indicator and buzzer)  |   | (h) |    | Take vehicle to Lexus dealer. |
| (c) |  | Fasten front passenger's seat belt.       | (i) |    | Close all doors.              |
|     | (On the center console)   |   | (j) |    | Replace bulb.                 |
| (d) |  | Take vehicle to Lexus dealer immediately. | (k) |    | Take vehicle to Lexus dealer. |
| (e) |  | Stop and check.                           | (l) |   | Stop and check.               |
|     |   |   | (m) |  | Add washer fluid.             |

(n)  Fill up tank.

(o) Key reminder buzzer Remove key.

### (a) Brake System Warning Light

This light has the following two functions:

#### **Parking brake reminder**

If this light is on, make sure the parking brake is fully released. The light should go off.

#### **Low brake fluid level warning**

If this light comes on and stays on while you are driving, slow down and pull off the road. Then stop the vehicle carefully. Remember that stopping distance and pedal effort may be increased. There may be a problem somewhere in the brake system. Check the fluid level of the see-through reservoir.

To make sure the parking brake has not caused the warning light to come on, check to see that the parking brake is fully released.

#### **If the brake fluid level is low ...**

At a safe place, test your brakes by starting and stopping.

- If you judge that the brakes still work adequately, drive cautiously to your nearest dealer or shop for repairs.
- If the brakes are not working, have the vehicle towed in for

## GAUGES, METERS AND SERVICE REMINDER INDICATORS

---

repairs. (For towing information, see page 364.)

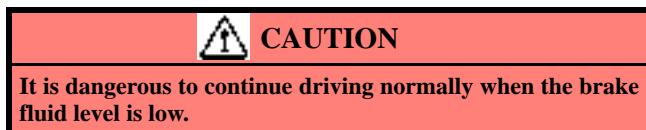

### **If the brake fluid level is correct ...**

Have the warning system checked by your Lexus dealer.

### **(b) Driver's Seat Belt Reminder Light and Buzzer**

The light and buzzer remind you to buckle up the driver's seat belt.

Once the ignition key is turned to "ON" or "START", the reminder light flashes and buzzer sounds if the driver's seat belt is not fastened. Unless the driver fastens the belt, the light keeps flashing and the buzzer stops after about 4 to 8 seconds.

### **(c) Front Passenger's Seat Belt Reminder Light**

The light reminds you to buckle up the front passenger's seat belt.

Once the ignition key is turned to "ON" or "START", the reminder light flashes if a front passenger sits in the front passenger seat and does not fasten the seat belt. Unless the front passenger fastens the belt, the light keeps flashing.

If luggage load is placed on the front passenger seat, depending on its weight and how it is placed on the seat, built-in sensors in the seat cushion may detect the pressure, causing the reminder light to come on.

## GAUGES, METERS AND SERVICE REMINDER INDICATORS

---

### (d) SRS Warning Light

**The indicator comes on when the ignition key is turned to the "ACC" or "ON" position. It goes off after about 6 seconds. This means the SRS is operating properly.**

The SRS warning light system monitors the airbag sensor assemblies, front airbag sensors, inflators, seat belt pretensioners, warning light, interconnecting wiring and power sources.

If either of the following conditions occurs, this indicates a malfunction somewhere in the parts monitored by the warning light system. Contact your Lexus dealer as soon as possible to service the vehicle.

- The light does not come on as described above.
- The light stays on or flashes.
- The light comes on or starts flashing while driving.

If the light stays on, it indicates that the driver and front passenger airbags fail. If the light flashes, the side airbags and/or seat belt pretensioners fail.

### (e) Discharge Warning Light

This light warns that the battery is being discharged.

If it comes on while you are driving, stop the vehicle, turn off the engine, and check for the cause. Look first at the engine drive belt.

- If it is loose or broken, the generator will not charge the battery properly.
- If the belt is O.K., there is a problem somewhere in the charging system.

The engine ignition will continue to operate, however, until the battery is discharged. Turn off the air conditioning, blower, radio, etc., and drive directly to the nearest Lexus dealer or repair shop.

### ***NOTICE***

***Do not continue driving if the engine drive belt is broken or loose.***

## GAUGES, METERS AND SERVICE REMINDER INDICATORS

---

### (f) Low Oil Pressure Warning Light

This light warns that the engine oil pressure is too low.

If it flickers or stays on while you are driving, pull off the road to a safe place and stop the engine immediately. Call a Lexus dealer or qualified repair shop for assistance.

The light may occasionally flicker when the engine is idling or it may come on briefly after a hard stop. There is no cause for concern if it then goes out when the engine is accelerated slightly.

The light may come on when the oil level is extremely low. It is not designed to indicate low oil level, and the oil level must be checked using the oil level dipstick.

#### **NOTICE**

***Do not drive the vehicle with the warning light on – even for one block. It may ruin the engine.***

### (g) Malfunction Indicator Lamp

This lamp comes on in the following cases.

- The fuel tank is completely empty. (See "Fuel gauge" on page 52 for instructions.)
- The fuel tank cap is not tightened securely. (See "Fuel tank cap" on page 105 for instructions.)
- There is a problem somewhere in your engine or automatic transmission electrical system.

If it comes on while you are driving in case "c.", have your vehicle checked/repared by your Lexus dealer as soon as possible.

### (h) "ABS" Warning Light

This light warns that there is a problem somewhere in your anti-lock brake system.

If the light comes on while you are driving, have your vehicle checked by your Lexus dealer as soon as possible.

The light will come on when the ignition key is turned to "ON", and will go off after about a few seconds.

When the "ABS" warning light is on (and the brake system warning light is off), the brake system operates conventionally but anti-lock brake system is not assisting brake performance so that the wheels could lock up during a sudden brake or braking on slippery road surfaces.

## GAUGES, METERS AND SERVICE REMINDER INDICATORS

---

### (i) Open Door Warning Light

This light remains on until all the doors are completely closed.

### (j) Rear Light Failure Warning Light

If this light comes on when the headlight switch is turned on (at the first or second clickstop), it indicates that one or more of the tail lights are burned out.

If it comes on when the brake pedal is depressed, one or more stop lights are burned out.

Have defective bulbs replaced as soon as possible.

### (k) "TRAC OFF" Indicator/Warning Light

This light comes on when the ignition key is turned to "ON", and will go off after about a few seconds. This means that the system is operating properly.

If the light flashes, this indicates a malfunction in the traction control system. Contact your Lexus dealer as soon as possible to service the vehicle.

### (l) Automatic Transmission Fluid Temperature Warning Light (Four-wheel drive models only)

This light warns that the automatic transmission fluid temperature is too high.

If this light comes on while you are driving, slow down and pull off the road. Stop the vehicle at a safe place and put the selector lever in "P" and leave the engine idling until the light goes off. If the light goes off, you can start the vehicle again. If the light does not go off, call a Lexus dealer or qualified repair shop for assistance.

#### **NOTICE**

*Continued driving with the warning light on may damage the automatic transmission.*

### (m) Low Washer Fluid Warning Light

This light comes on when the fluid level in the tank becomes nearly empty. Fill the tank as soon as possible.



## GAUGES, METERS AND SERVICE REMINDER INDICATORS

---

### (n) Low Fuel Level Warning Light

This light comes on when the fuel level in the tank becomes nearly empty. Fill the tank as soon as possible.

On inclines or curves, due to the movement of fuel in the tank, the low fuel level warning light may come on earlier than usual.

### (o) Key Reminder Buzzer

This buzzer reminds you to remove the key when you open the driver's door with the ignition key in the "ACC" or "LOCK" position.

### How to check all the service reminder indicators

(except the low fuel level warning light):

1. Apply the parking brake.
2. Open the door.

The following service reminder indicator should come on. It goes off when you close the door completely.



3. Turn the ignition key to "ACC".

The following service reminder indicator should come on. It goes off after 6 seconds.



4. Turn the ignition key to "ON".

The following service reminder indicators should come on.



## GAUGES, METERS AND SERVICE REMINDER INDICATORS

---



The following service reminder indicators go off after a few seconds.



If any service reminder indicator or warning buzzer does not function, either the bulb is burned out or circuit is in need of repair. Have it checked by your Lexus dealer as soon as possible.

## CRUISE INFORMATION DISPLAY

## GAUGES, METERS AND SERVICE REMINDER INDICATORS

---



The following information is shown with the ignition switched "ON".

- (1) Driving time
- (2) Average vehicle speed
- (3) Average fuel consumption
- (4) Momentary fuel consumption

The displayed values in the cruise information display indicate the general driving condition, so those may not show precise and actual condition.

## GAUGES, METERS AND SERVICE REMINDER INDICATORS

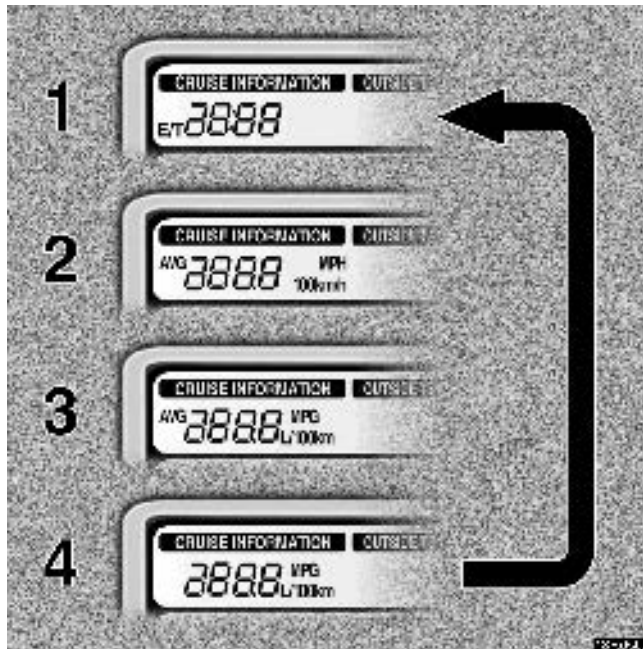

To change the mode, push the "INFO" button briefly on the audio control panel.

When the ignition switch is turned to "ON", the mode displayed just before the ignition switch is turned off will appear.

### (1) Driving time (Figures with "E/T")

**The elapsed time after the engine started is displayed.**

When the engine is started again, the driving time is counted from 0. Up to 12 hours can be displayed. When the driving

## GAUGES, METERS AND SERVICE REMINDER INDICATORS

---

time exceeds 12 hours, recounting starts.

### **(2) Average vehicle speed (Figures with "AVG MPH" or "AVG km/h")**

**The average vehicle speed is calculated and displayed based on the total driving distance and the total driving time with the engine running.**

The displayed value is updated every 10 seconds.

To calculate from the beginning, push the "INFO" button for more than 1 second.

### **(3) Average fuel consumption (Figures with "AVG MPG" or "AVG L/100 km")**

**The average fuel consumption is calculated and displayed based on the total driving distance and the total fuel consumption with the engine running.**

The value is updated every 10 seconds.

To calculate from the beginning, push the "INFO" button for more than 1 second.

### **(4) Momentary fuel consumption (Figures with "MPG" or L/100 km")**

**The momentary fuel consumption is calculated and displayed based on the driving distance and the fuel consumption for 2 seconds with the engine running.**

The value is updated every 2 seconds.

If you are driving at low speeds just before stopping, the accurate figure may not be shown.

*For the display (2), (3) or (4), "--" will appear in case the data for calculation is not appropriate.*

## INSTRUMENT PANEL LIGHT CONTROL



To adjust the brightness of the instrument panel lights,  
turn the knob.



# *SECTION 1 - 4*

---

## **INSTRUMENTS AND CONTROLS**

### **Interior equipment**

Vanity mirrors .....	72
Interior lights .....	73
Personal light .....	74
Ignition switch light .....	75
Clock .....	76
Outside temperature display .....	80
Cigarette lighter and ashtray .....	80
Power outlets .....	83
Glove box .....	84
Garage door opener .....	86
Cup holders .....	89
Overhead console box .....	93
Auxiliary boxes .....	95
Luggage cover .....	97
Floor mat .....	98
Tie-down hooks .....	100
Luggage stowage precautions .....	100



## INTERIOR EQUIPMENT

---

### VANITY MIRRORS



To use the vanity mirrors, swing the sun visor down and open the cover.

Sun visors

The vanity light comes on when you open the cover.

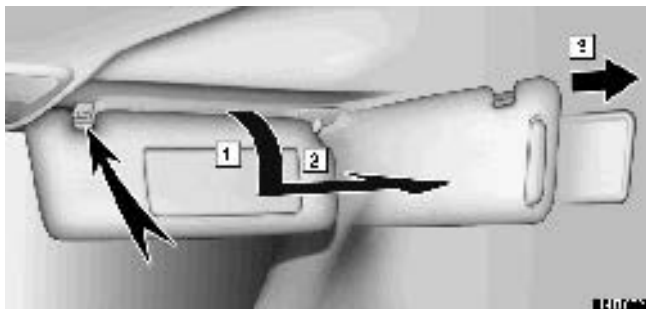

- 1 To block out glare from the front , swing the sun visor down.
- 2 To block out glare from the side, remove the sun visor from the hook and swing it to the side.
- 3 To block out glare coming obliquely from behind you, pull out an extension plate from the inside of the sun visor.

## INTERIOR LIGHTS

### *NOTICE*

*Take care not to swing back the sun visor without pushing back the extension plate so as not to damage the extension plate.*

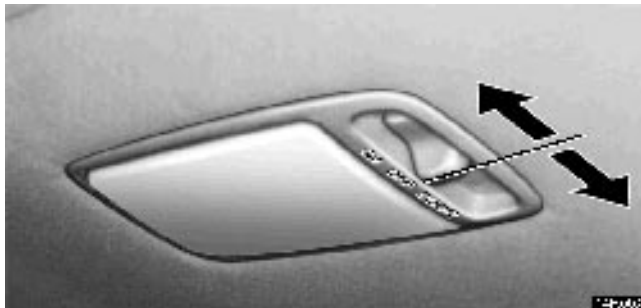

## INTERIOR EQUIPMENT

---

**To turn on the interior light, slide the switch.**

### **Center light:**

With the switch in the "DOOR" position, the light comes on when any of the side doors or back door are opened. After all the doors are closed, the light remains on for about 15 seconds and then goes out.

However, in the following cases, the light goes out immediately:

1. All the doors are closed when the ignition key is in "ACC" or "ON" position.
2. The ignition key is turned to "ACC" or "ON" when the light is still on.
3. All the doors are locked when the light is still on.
4. One door is closed with the lock button pushed in while the other doors are locked.

### **Rear light:**

With the switch in the "DOOR" position, the light comes on when the back door is opened. The light goes out immediately when the back door is closed.



74

**off, push the switch again.**

## PERSONAL LIGHT

### **Vehicles without moon roof**

**Vehicles with moon roof**



To turn on the personal light, push the switch. To turn it off, push the switch again.

**IGNITION SWITCH LIGHT**

## INTERIOR EQUIPMENT

---



**For easy access to the ignition switch, the ignition switch light comes on when the driver's door is unlocked.**

The light remains on for about 15 seconds and goes out after all the doors are closed. However, the light goes out immediately when all the doors are locked or the ignition key is in the "ACC" or "ON" position.



## CLOCK

- ▶ **1** *12-hour display mode*   **2** *24-hour display mode*
- 3** *Time setting mode (indication blinking)*
- 4** *Alarm setting mode (indication blinking)*

**The digital clock indicates the time with the ignition key at the "ACC" or "ON" position. The mode can be changed by pushing the "CLOCK" button on the audio control panel.**

With the tail lights on, the brightness of the time indication will be reduced.

If the electrical power source has been disconnected from the clock, the time display will automatically be set to 1:00 (one o'clock).

## INTERIOR EQUIPMENT

---



### ► *Adjusting the time*

1. Push the "CLOCK" button to enter the time setting mode.
2. Push the "H" or "M" button to adjust the time.
3. Push the "CLOCK" button again.

To set the clock by the radio, adjust the minute to "00" at step 2. and push the "CLOCK" button by the time signal from the radio.

### ► *Setting the alarm*

1. Push the "CLOCK" button to display the alarm setting mode.
2. Input the time you want to sound an alarm by pushing "H" or "M" button.
3. Push the button indicated by the "bell" mark. The bell indicator appears.

An alarm sounds for about 20 seconds at the set time every day. To stop the alarm, push the "CLOCK" button.

To disable the alarm activation, push the button indicated by the "bell" mark at step 3. and turns off the bell indicator on the display.



## INTERIOR EQUIPMENT

---

### OUTSIDE TEMPERATURE DISPLAY



**This display shows the outside temperature when the ignition switch is on.**

The displayed temperature ranges from  $-30^{\circ}\text{C}$  ( $-22^{\circ}\text{F}$ ) up to  $50^{\circ}\text{C}$  ( $122^{\circ}\text{F}$ ). If the temperature does not appear on the display or it shows "--", take your vehicle to your Lexus dealer.

### CIGARETTE LIGHTER AND ASHTRAY

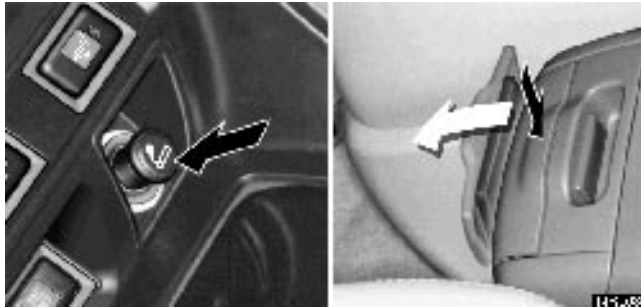

► *Front cigarette lighter and ashtray*

**To use the cigarette lighter, press it in. When it becomes heated, it automatically pops out ready for use. To use the ashtray, push the ashtray cover.**

Do not hold the cigarette lighter pressed in.

If the engine is not running, the ignition key must be in the "ACC" position.

When finished with your cigarette, thoroughly extinguish it in the ashtray to prevent other cigarette butts from catching fire. After using the ashtray, push it back in completely.

To remove the ashtray, just pull it up.

Use a Lexus genuine cigarette lighter or equivalent for replacement.

## INTERIOR EQUIPMENT

---



### CAUTION

To reduce the chance of injury in case of an accident or sudden stop while driving, always close the ashtray completely after using.

## POWER OUTLETS



► *Rear end of the console box*



► *In the luggage compartment*

The power outlets are designed for power supply for car accessories.

## INTERIOR EQUIPMENT

---

The ignition key must be in the "ACC" or "ON" position for the power outlets to be used.

## GLOVE BOX

### ***NOTICE***

- *To prevent the fuse from being blown, do not use the electricity over the total vehicle capacity of 12V/120W (front and rear outlets together).*
- *To prevent the battery from being discharged, do not use the power outlet longer than necessary when the engine is not running.*
- *Close the power outlet lid when the power outlet is not in use. Inserting a foreign object other than the appropriate plug that fits the outlet, or allowing any liquid into the outlet may cause electrical failure or short circuits.*

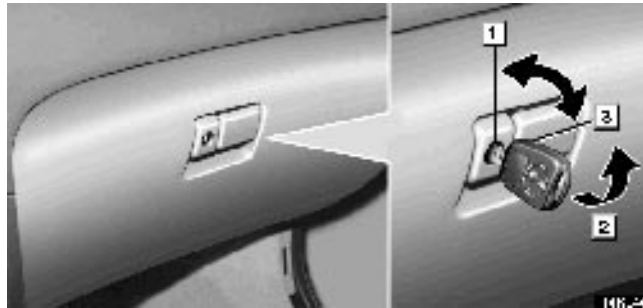

► **1** *Unlock* **2** *Open* **3** *Lock*

**To open the glove box door, pull the lever. To lock the glove box door, insert the master key and turn it clockwise.**

With the tail lights on, the glove box light will come on when the glove box door is open.

For the CD automatic changer, see page 258.



**CAUTION**

**To reduce the chance of injury in case of an accident or a sudden stop, always keep the glove box door closed while driving.**

## INTERIOR EQUIPMENT

---

### GARAGE DOOR OPENER

The garage door opener is manufactured under license from HomeLink<sup>®</sup> and can be programmed to operate garage doors, estate gates, security lighting, etc.

#### (a) Programming HomeLink<sup>®</sup>

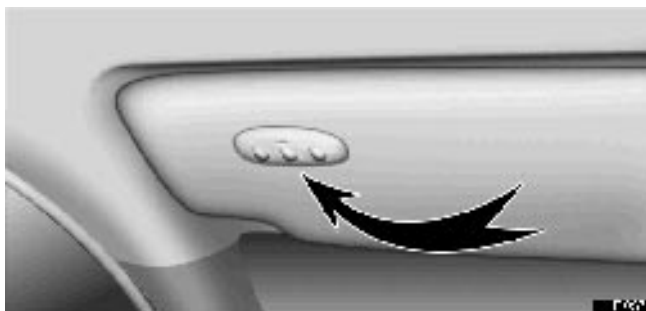

The HomeLink<sup>®</sup> has 3 buttons and can be programmed to operate 3 separate devices.

Prepare the HomeLink<sup>®</sup> for programming by erasing all codes or the memorized data programmed by the former owner. Follow the procedure in "(c) Erasing the garage door opener memory".

1. Decide which one of the 3 buttons you want to program. Push and hold down the button for about 20 seconds until the indicator light begins to flash. While holding this button, follow steps "2" and "3".

## INTERIOR EQUIPMENT

---

2. Bring the hand held garage door opener within about 25 mm (1 in.) of the button being programmed and push the button on the hand held garage door opener. The signal from the hand held garage door opener is sent to the vehicle's opener.

3. When the frequency and code is registered, the indicator light flashes rapidly. At this point, you can release both buttons.

4. To program the remaining buttons, repeat steps "1" through "3".

If you want to replace an existing program with a new program, select the button you want to program. Follow the procedure from step 1.

**If the transmitter has a "rolling code feature", it is necessary to program the in-garage receiver after programming HomeLink®.**

**1. Locate the "training" or "learning" button on the in-garage receiver and push and release this button. Location of the button may vary by the garage door opener manufacturer.**

**2. Firmly push and release the trained HomeLink® button 2 times (some garage door manufacturer may require you to push the HomeLink® button up to 3 times) to complete the process.**

**The garage door should now operate when the HomeLink® button is pushed.**

Do not use the HomeLink® universal transmitter with any garage door opener that lacks the safety stop and reverse feature as required by Federal Safety Standards. This includes any garage door opener model manufactured before April 1, 1982.



## INTERIOR EQUIPMENT

---



### CAUTION

When programming or operating the garage door opener, make sure there is no one around the moving door. It is dangerous if someone is caught.

#### (b) Operating the garage door opener

Push the appropriate button to activate the garage door opener. The indicator light comes on. The garage door opener continues to send the signal for up to 20 seconds as long as the button is pushed.

#### (c) Erasing the garage door opener memory

Push and hold down the 2 outside buttons for about 20 seconds until the indicator light flashes. All memorized data will be erased.

**FCC ID: CB2V94800**  
**CANADA: 1763 102 264**

This device complies with FCC Rules part 15. Operation is subject to the following two conditions: (1) This device may not cause harmful interference, and (2) this device must accept any interference that may be received, including interference that may cause undesired operation. **WARNING: This transmitter has been tested and complies with FCC and DOC/MDC rules. Changes or modifications not expressly approved by the partly responsible for compliance could void the user's authority to operate the device.**

## CUP HOLDERS

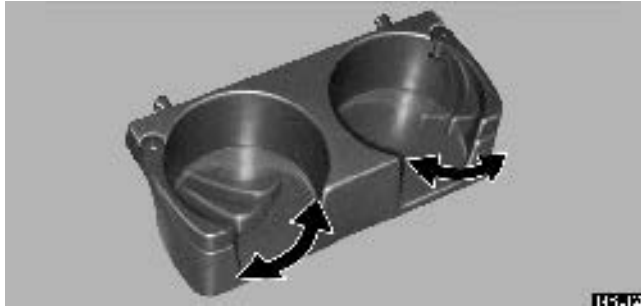

► **Front cup holder**

**To use the cup holder, slide the console box.**

The cup holder is designed for holding cups or drink-cans securely in its holes. You can adjust the arms to 3 stages.

## INTERIOR EQUIPMENT

---

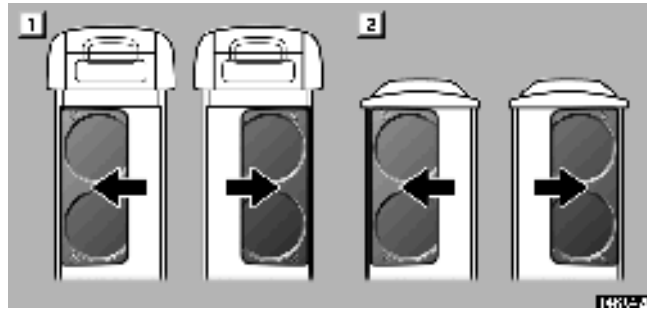

► **1** *Upper console position* **2** *Lower console position*

### Installation

The cup holder can be installed as you desired using the upper and lower console boxes.

When the upper console is used as a cup holder, the lower console may not be used. This applies to the opposite case when the lower console is used.

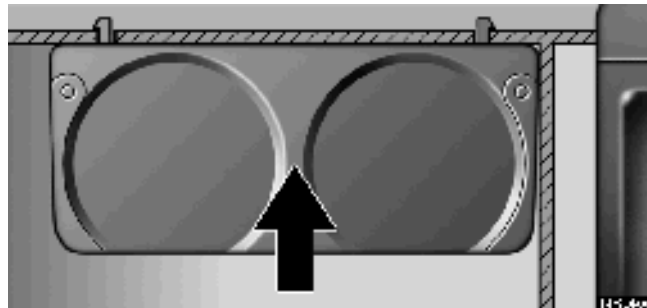

Insert the rear tabs into the cutouts of the console box inside.

**Removal**

Pull out the console box toward you.

 <b>CAUTION</b>
<ul style="list-style-type: none"><li>• Do not place anything else other than cups or drink-cans on the cup holder, as such item may be thrown about in the compartment and possibly injure people in the vehicle during sudden braking or an accident.</li><li>• To reduce the chance of injury in case of an accident or sudden stop while driving, keep the cup holder closed when not in use.</li></ul>



## INTERIOR EQUIPMENT

---

### ►Rear cup holder

**To use the cup holder, push the button of the console box.**

The cup holder is designed for holding cups or drink-cans securely in its holes. You can adjust the arms to 3 stages.



#### CAUTION

- **Do not place anything else other than cups or drink-cans on the cup holder, as such item may be thrown about in the compartment and possibly injure people in the vehicle during sudden braking or an accident.**
- **To reduce the chance of injury in case of an accident or sudden stop while driving, keep the cup holder closed when not in use.**

## OVERHEAD CONSOLE BOX

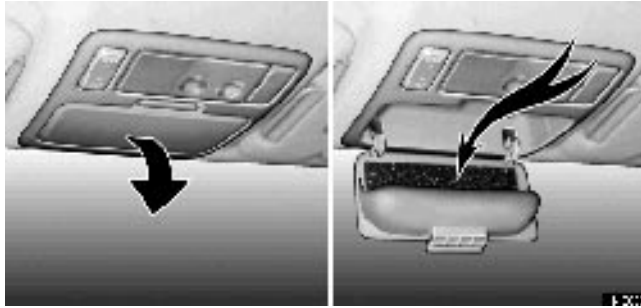

To use the overhead console box, open it as shown above.



### CAUTION

- To reduce the chance of injury in case of an accident or a sudden stop, always keep the overhead console box closed while driving.
- As this box is designed for holding eyeglasses, do not place any object heavier than approximately 60 g (0.13 lb.) in it. Heavier objects may cause the box to open and contents to fly out resulting in injuries.

## INTERIOR EQUIPMENT

---

### *NOTICE*

*In hot weather, inside of the vehicle becomes very hot. Do not leave anything flammable or deformable such as a lighter, the glasses, etc. inside.*

## AUXILIARY BOXES

Your vehicle has several types of auxiliary box. To use them, open as shown in the following illustrations.

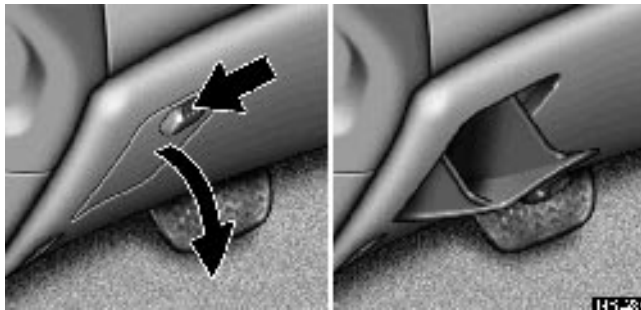

► *On the instrument panel*



► *In the right side of luggage compartment*



## INTERIOR EQUIPMENT

---



### CAUTION

To reduce the chance of injury in case of an accident or a sudden stop, always keep the auxiliary box closed while driving.

## LUGGAGE COVER

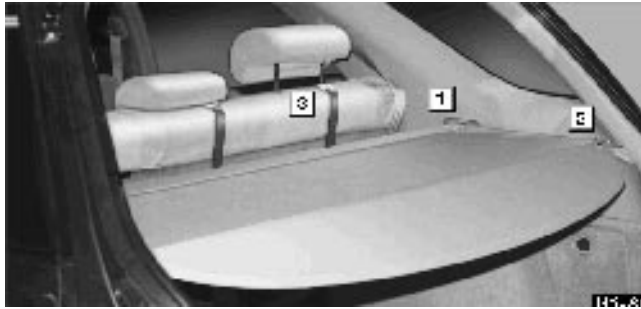

### Installation

- 1 Insert the luggage cover bars into the grooves of the deck side bars.
- 2 Pull out the cover and hook the luggage cover on holders on both sides of the deck side bars.
- 3 Fit the hooks at the strings of the luggage cover end on the poles of the head restraints.

### Removal

Reverse the order of the installation.

### **NOTICE**

*Do not place anything on the luggage cover. Such items may be thrown about and possibly injure people in the vehicle during sudden braking or an accident.*

## INTERIOR EQUIPMENT

---

### FLOOR MAT

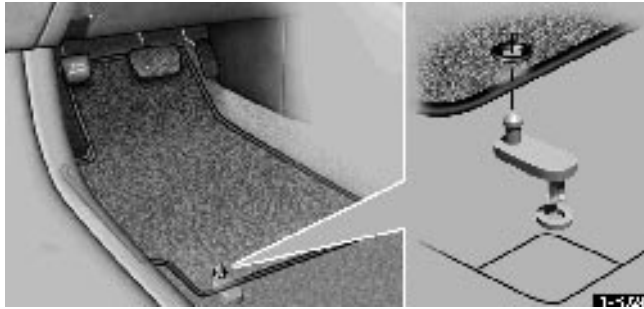

**Use a floor mat of the correct size.**

If the floor carpet and floor mat have a hole, then it is designed for use with a locking clip. Fix the floor mat with locking clip into the hole in the floor carpet.

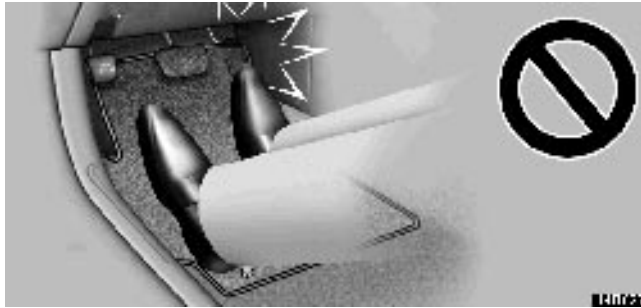

**CAUTION**

**Make sure the floor mat is properly placed on the floor carpet. If the floor mat slips and interferes with the movement of the pedals during driving, it may cause an accident.**

## INTERIOR EQUIPMENT

---

### TIE-DOWN HOOKS



To secure your luggage, use the tie-down hooks as shown above.

See "Luggage stowage precautions" for precautions to observe in loading luggage.

### LUGGAGE STOWAGE PRECAUTIONS

**When stowing luggage or cargo in the vehicle, observe the following:**

- Put luggage or cargo in the luggage compartment when at all possible. Be sure all items are secured in place.
- Be careful to keep the vehicle level. Placing the weight as far forward as possible helps maintain vehicle balance.
- For better fuel economy, do not carry unnecessary weight.



**CAUTION**

- To prevent luggage or packages from sliding forward during braking, do not stack anything in the luggage compartment higher than the seatbacks. Keep luggage or packages low, as close to the floor as possible.
- Never allow anyone to ride in the luggage compartment. It is not designed for passengers. They should ride in their seats with their seat belts properly fastened. Otherwise, they are much more likely to suffer serious bodily injury, in the event of sudden braking or a collision.
- Do not drive with objects left on top of the instrument panel. They may interfere with the driver's field of view. Or they may move during sharp vehicle acceleration or turning, and impair the driver's control of the vehicle. In an accident they may injure the vehicle occupants.

***NOTICE***

*Do not load the vehicle beyond the vehicle capacity weight specified on the tire pressure label.*



# SECTION 1 - 5

---

## INSTRUMENTS AND CONTROLS

### Exterior equipment

Hood .....	103
Fuel tank cap .....	105
Moon roof .....	108

### HOOD

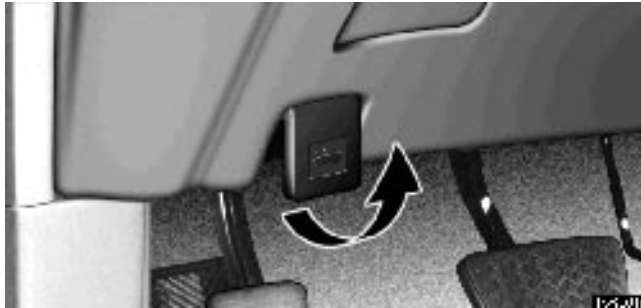

To open the hood, pull the hood lock release lever under the instrument panel. The hood will spring up slightly.



## EXTERIOR EQUIPMENT

---

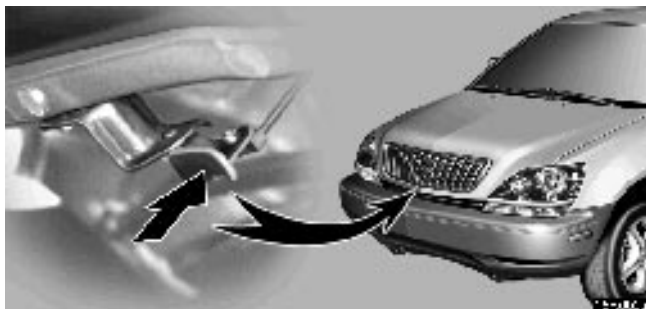

**Insert your fingers under the hood, push up the auxiliary catch lever and lift the hood.**

Before closing the hood, check to see that you have not forgotten any tools, rags, etc. Then lower the hood and make sure it locks.



### **CAUTION**

**Before driving, be sure that the hood is securely locked. Otherwise, the hood may open unexpectedly while driving and an accident may occur.**

## FUEL TANK CAP



1. To open the fuel filler door, pull the lever up.  
When refueling, turn off the engine.

## EXTERIOR EQUIPMENT

---



### CAUTION

- Do not smoke, cause sparks or allow open flames when refuelling. The fumes are flammable.
- When opening the cap, do not remove the cap quickly. In hot weather, fuel under pressure could cause injury by spraying out of the filler neck if the cap is suddenly removed.

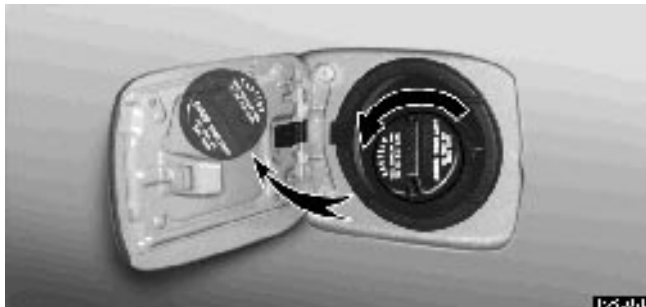

**2. To remove the fuel tank cap, turn the cap slowly counterclockwise, then pause slightly before removing it. The removed cap can be stored on the back side of the fuel filler door.**

It is not unusual to hear a slight swoosh when the cap is opened. When installing the cap, turn the cap clockwise until you hear a click.

If the cap is not tightened securely, the malfunction indicator lamp comes on. Make sure the cap is tightened securely.

The indicator lamp goes off after driving several times. If the indicator lamp does not go off, contact your Lexus dealer as soon as possible.



**CAUTION**

- **Make sure the cap is tightened securely to prevent fuel spillage in case of an accident.**
- **Use only a genuine Lexus fuel tank cap for replacement. It has a built-in check valve to reduce fuel tank vacuum.**

## EXTERIOR EQUIPMENT

---

### MOON ROOF



► **1** Open **2** Close

To slide open the moon roof, push the switch on the "SLIDE OPEN" side briefly. The moon roof will open and stop partway 50 mm (2.0 in.) from the fully opened position. When you push the switch again, the moon roof will open fully. To stop partway, push the same side or "TILT UP" side briefly while the moon roof is moving .

As driving with the moon roof opened fully will cause wind throbs, we recommend you to drive with the moon roof partway 50 mm (2.0 in.) from the fully opened position.

To operate the moon roof, the ignition key must be in the "ON" position.

The sun shade can be opened or closed manually. However, if you open the moon roof, the sun shade will be opened with the moon roof.

To close the moon roof, push the switch on the "TILT UP" side. The moon roof will fully close. To stop partway, push the same side or "SLIDE OPEN" side briefly.

**To slide open the tilted-up moon roof:**

Push the switch on the "SLIDE OPEN" side to tilt down the moon roof. After releasing the switch, push the switch on the same side again.



► **1** Lower **2** Tilt up

**To tilt up the rear end of the moon roof fully, push the switch on the "TILT UP" side or on the "SLIDE OPEN" side to lower it.**

**To tilt up the slide-opened moon roof:**

Push the switch on the "TILT UP" side to close the moon roof fully. After releasing the switch, push the switch on the same side again.

**Key off operation:** Even if the ignition key is turned to the "ACC" or "LOCK" position with all the door closed, the moon roof can be operated until any of the doors is opened (or for about 45 seconds).

### **Operating the moon roof from outside the vehicle**

**(a) The moon roof can be closed or opened using an ignition key.\***

**Insert the ignition key into the key hole on the driver's door.**

**To close the moon roof:** Turn the key in the locking direction and hold it.

After the door is locked, the moon roof begins to close. To stop in the middle, return the key.

**To open the moon roof:** Turn the key in the unlocking

## EXTERIOR EQUIPMENT

---

direction and hold it.

After the door is unlocked, the moon roof begins to open. To stop in the middle, return the key.

*NOTE: \*This feature can be set inoperative, or sliding open or tilting up can be selected. Ask your Lexus dealer for details.*

**(b) The moon roof can be opened using a wireless remote control key.**

**Push and hold the "UNLOCK" button. When you release the button, the moon roof stops opening.**

### **Jam protection function**

During closing operation, the moon roof stops and is open if something gets caught into the roof opening.

If an impact is given to the moon roof, this function may work without anything caught.



**CAUTION**

- Never try jamming any part of your body to make the jam protection function work intentionally.
- The jam protection function may not work when something gets caught just before the moon roof fully closed.



**CAUTION**

To avoid serious personal injury, you must do the following.

- While the vehicle is moving, always keep the head, hands and other parts of the body of all occupants away from the roof opening. Otherwise, you could be seriously injured if the vehicle stops suddenly or if the vehicle is involved in an accident.
- Always make sure nobody places his/her head, hands and other parts of the body in the roof opening before you close the roof. If someone's neck, head or hands gets caught in the closing roof, it could result in a serious injury. When anyone closes the roof, first make sure it is safe to do so.
- Never leave small children alone in the vehicle, especially with the ignition key still inserted. They could use the moon roof switches and get trapped in the roof opening. Unattended children can become involved in serious accidents.
- Never sit on top of the vehicle around the roof opening.



# *SECTION 1 - 6*

---

## **INSTRUMENTS AND CONTROLS**

### **Comfort adjustment**

Front seats .....	112
Rear seats .....	123
Armrests .....	128
Head restraints .....	128
Tilt steering wheel .....	130
Outside rear view mirrors .....	132
Inside rear view mirror .....	136
Seat belts .....	139
Supplemental restraint system (SRS) .....	152
Child restraint .....	175
Driving position memory system .....	210

## **FRONT SEATS**

### **Front seat precautions**



**CAUTION**

The SRS side airbags are installed in the driver and front passenger seats. Observe the following precautions.

- Do not lean over the front door when the vehicle is in use. The side airbag inflates with considerable speed and force; you may be killed or severely injured.
- Do not modify or replace the seats or the surface of the seats with side airbags. Such changes may disable the system, or cause the side airbags to inflate, resulting in death or serious injury. Consult your Lexus dealer.
- Do not use accessories for the seats which cover the parts where the side airbags should inflate. Such accessories may prevent the side airbags from activating correctly, causing death or serious injury.

## COMFORT ADJUSTMENT

---

### Seat adjustment precautions

Adjust the driver's seat so that the foot pedals, steering wheel and instrument panel controls are within easy reach of the driver.



#### CAUTION

- Do not adjust the seat while the vehicle is moving as the seat may unexpectedly move and cause the driver to lose control of the vehicle.
- Be careful not to hit the seat against a passenger, luggage or the rear seat.

#### NOTICE

*Do not operate the control switch in more than one dimension at a time. It may cause electrical overload.*

### Adjusting front seats

## COMFORT ADJUSTMENT

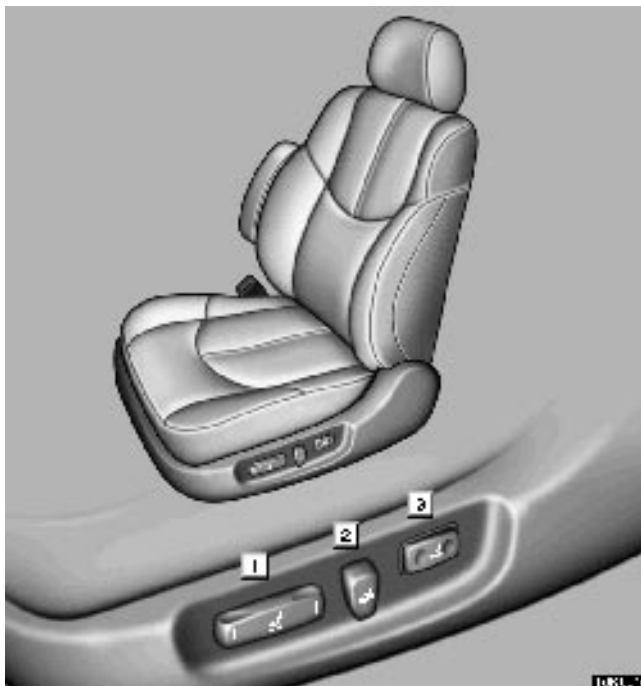

- ▶ **1** *Seat position control switch, seat cushion angle and height control switch*
- 2** *Seatback angle control switch*
- 3** *Lumbar support control switch*

## COMFORT ADJUSTMENT

---

### Adjusting seat position

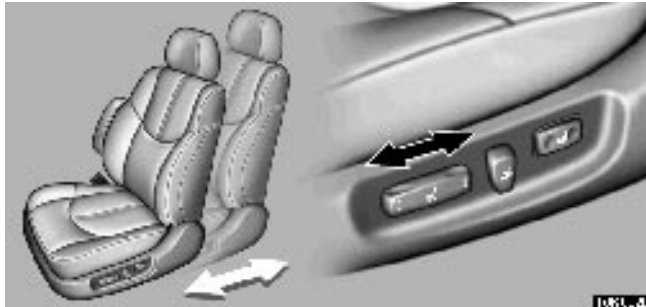

Move the control switch in the desired direction.

Releasing the switch will stop the seat in that position. Do not place anything under the seat. It might interfere with the seat movement.

### Adjusting seatback angle

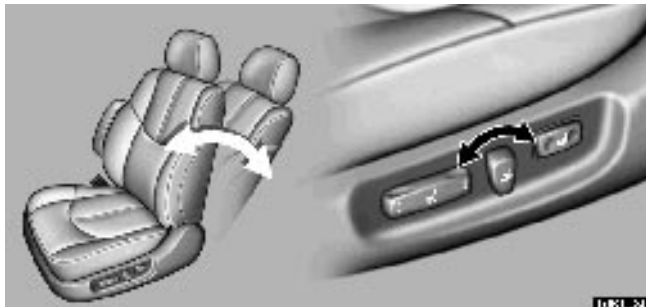

**Move the control switch in the desired direction.**

Releasing the switch will stop the seatback in that position.



**CAUTION**

**To reduce the risk of sliding under the lap belt during a collision, avoid reclining the seatback any more than needed. The seat belts provide maximum protection in a frontal or rear collision when the driver is sitting up straight and well back in the seats. If you are reclined, the lap belt may slide past your hips and apply restraint forces directly to the abdomen. Therefore, in the event of a frontal collision, the risk of personal injury may increase with increasing recline of the seatback.**

## COMFORT ADJUSTMENT

---

### Adjusting seat cushion angle and height (driver's seat only)

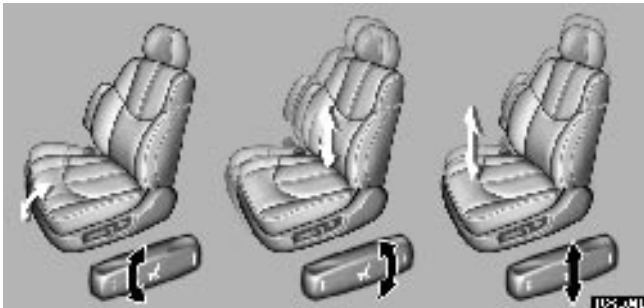

Move the control switch in the desired direction.

Releasing the switch will stop the seat cushion in that position.

### Adjusting lumbar support (driver's seat only)



**Push the control switch on either side.**

The amount of lumbar support will change as long as the switch is pushed.

**Flattening seatbacks**



## COMFORT ADJUSTMENT

---

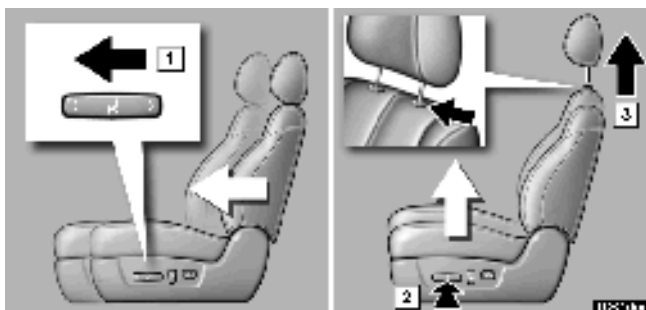

**Before flattening seatbacks, slide the rear seats as far back as possible.**

- 1** Push the seat position control switch forward to move the seat forward.
- 2** Push the seat position control switch upward to raise the seat (driver's seat only).
- 3** Push the lock release button on the head restraint to remove it.

## COMFORT ADJUSTMENT

---

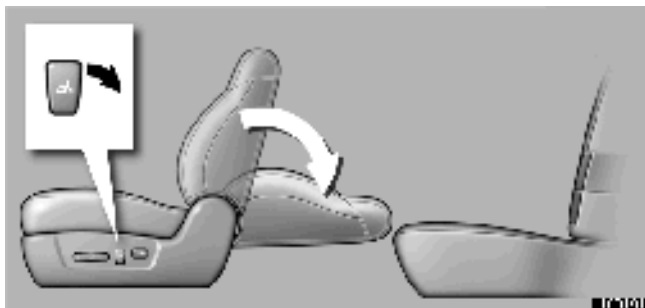

Move the seatback angle control switch backward to flatten the seatback.

## COMFORT ADJUSTMENT

---

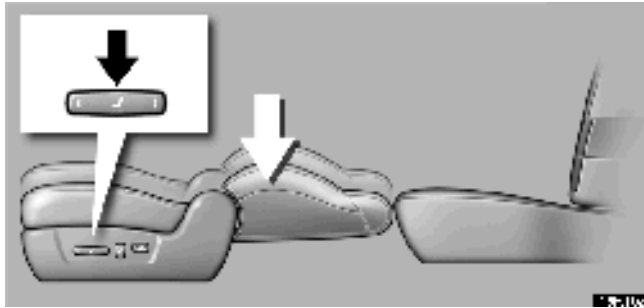

Push the seat position control switch downward to lower the seat at the same level as the rear seat (driver's seat only).

After returning the seat to its original position, be certain to replace the head restraint.



### CAUTION

- Do not allow passengers to ride on the flattened seat while driving; use the seat in the normal position.
- After putting back the seat, try pushing the seatback forward and rearward to make sure it is secured in place. Be certain to replace head restraint.

## REAR SEATS

### Sliding and reclining rear seats

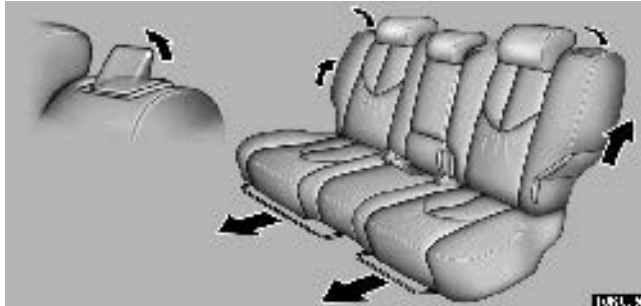

**Pull the lock release lever up. Then slide the seat to the desired position with slight body pressure and release the lever.**

When you move the seats forward and unlock the seatbacks, you can tilt the seatbacks a little rearward.

## COMFORT ADJUSTMENT

---



### CAUTION

To reduce the risk of sliding under the lap belt during a collision, avoid reclining the seatback any more than needed. The seat belts provide maximum protection when the passengers are sitting up straight and well back in the seats. If you are reclined, the lap belt may slide past your hips and apply restraint forces directly to the abdomen. Therefore, in the event of a frontal collision, the risk of personal injury may increase with increasing recline of the seatback.

**Folding down rear seatbacks**

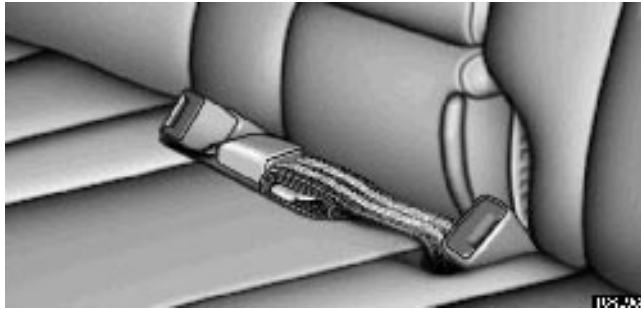

► *Before folding down rear seatbacks*

**Stow the rear seat belt buckle and center seat belt as shown in the illustration.**

This prevents the belts from falling out when you fold up the rear seats.

## COMFORT ADJUSTMENT

---

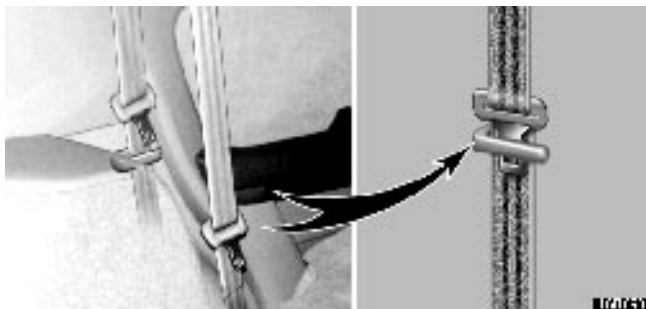

### ► *Seat belt hanger*

For the outer seat belts, use the seat belt hangers to prevent the belts from being tangled.

### ***NOTICE***

*The seat belt buckle and center seat belt must be stowed before you fold down the rear seatbacks.*



► *Folding down rear seatbacks*

Lower the head restraints to the lowest position, unlock the seatbacks and fold them down.

When returning the rear seats to their original position, lift up the seatbacks until they lock.



**CAUTION**

When returning seats to their original position:

- Make sure the seat belts are not twisted or caught under the seat and are arranged in their proper position and are ready to use.
- Make sure the seat is securely locked by pushing forward and rearward on the top of the seatback or by trying to pull up the edge of the bottom cushion.



## COMFORT ADJUSTMENT

---

### ARMRESTS

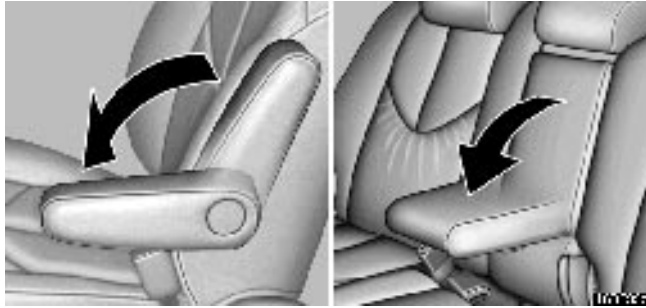

► *Front*

► *Rear*

To use the armrests, pull them down as shown above.

#### **NOTICE**

*To prevent damage to the armrests, avoid putting heavy loads on them.*

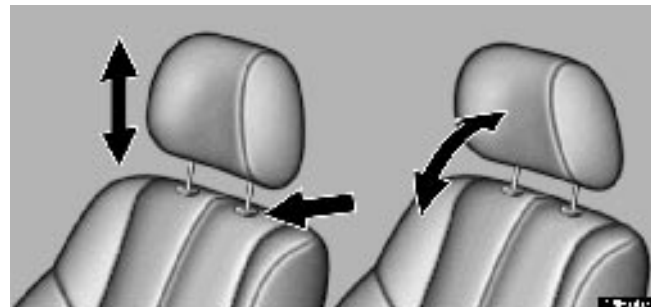

### HEAD RESTRAINTS

Front seats

**To raise the head restraint, pull it up. To lower it, press the lock release button and push the head restraint down. To move the head restraint forward or rearward, pull or push on the top.**

The head restraint is most effective when it is close to your head. Therefore, using a cushion on the seatback is not recommended.



### CAUTION

- Adjust the center of the head restraint so that it is closest to the top of your ears.
- After adjusting the head restraint, make sure it is locked in position.

- Do not drive with the head restraints removed.

Rear seats

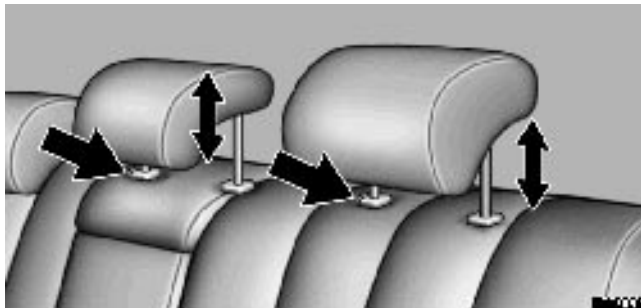

## COMFORT ADJUSTMENT

---

**To raise the head restraint, pull it up. To lower it, press the lock release button and push the head restraint down.**

The head restraint is most effective when it is close to your head. Therefore, using a cushion on the seatback is not recommended.



### CAUTION

- Adjust the center of the head restraint so that it is closest to the top of your ears.
- After adjusting the head restraint, make sure it is locked in position.
- Do not drive with the head restraints removed.

## TILT STEERING WHEEL



**To change the steering wheel angle, hold the steering wheel, pull up the lock release lever, tilt the steering wheel to the desired angle and release the lever.**

When the steering wheel is in a low position, it will spring up as you release the lock release lever.



### CAUTION

- Do not adjust the steering wheel while the vehicle is moving.
- After adjusting the steering wheel, try moving it up and down to make sure it is locked in position.

## OUTSIDE REAR VIEW MIRRORS



**Adjust the mirror so that you can just see the side of your vehicle in the mirror.**

Be careful when judging the size or distance of any object seen in the outside rear view mirror on the passenger's side. It is a convex mirror with a curved surface. Any object seen in a convex mirror will look smaller and farther away than if seen in a normal flat mirror.

When you push the rear window and outside rear view mirror defogger switch, the heater panels in the outside rear view mirrors will quickly clear the mirror surface.

**Some models:** When the inside rear view mirror darkens in "AUTO" mode, the outside rear view mirrors also darken to reduce the reflection of the headlights of the following vehicle. For details, see "Inside rear view mirror" on page 136.



**CAUTION**

- Do not adjust the mirror while the vehicle is moving. It may cause the driver to mishandle the vehicle and an accident may occur, resulting in personal injuries.
- Since the mirror surfaces can get hot, keep your hands off them when the rear window and outside rear view mirror defogger switch is on.

## COMFORT ADJUSTMENT

---

### Power rear view mirror control



**1** Master switch   **2** Control switch

To adjust the power rear view mirror, first place the master switch at "L" (left) or "R" (right), and push the control switch on the desired side.

The power rear view mirror can be adjusted when the key is in the "ACC" or "ON" position.

#### **NOTICE**

*If ice should jam the mirror, do not operate the control or scrape the mirror face. Use a spray de-icer to free the mirror.*

**Folding rear view mirrors**



**To fold the rear view mirror, push backward.**

The rear view mirrors can be folded backward for parking in restricted areas.



**CAUTION**

**Do not drive with the mirrors folded backward. Both the driver and passenger side rear view mirrors must be extended and properly adjusted before driving.**



## COMFORT ADJUSTMENT

---

### INSIDE REAR VIEW MIRROR

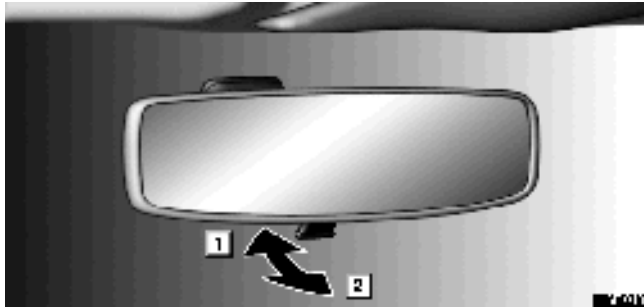

► *Type A*  1 *Day*  2 *Night*

**Adjust the mirror so that you can just see the rear of your vehicle in the mirror.**

**When driving at night, pull the lever toward you to reduce the glare from the headlights of vehicles behind you.**

Before adjusting the mirror to the position with most clarity, push the day–night change lever forward (daylight driving position).

Remember that by reducing glare you also lose some rear view clarity.



**CAUTION**

**Do not adjust the mirror while the vehicle is moving. It may cause the driver to mishandle the vehicle and an accident may occur resulting in personal injuries.**

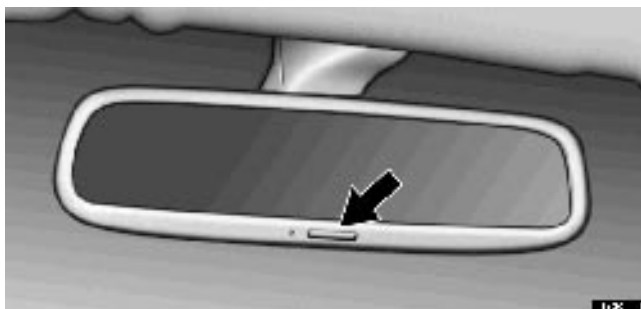

## COMFORT ADJUSTMENT

---

### ► *Type B*

**Adjust the mirror so that you can just see the rear of your vehicle in the mirror.**

**Pushing the switch changes the mode between "AUTO" and "DAY".**

The indicator comes on when the "AUTO" mode is selected.

**"DAY" mode: The mirror surface is normal.**

**"AUTO" mode: If the mirror detects light from the headlights of the vehicle behind you, the mirror surface darkens slightly to reduce the reflected light.**

When the inside rear view mirror surface changes, the outside rear view mirror surfaces will also become darker.

When the ignition key is inserted and turned on, the inside rear view mirror always turns on in the "AUTO" mode.

When the outside air temperature is low, it may take a little longer for the mirror to darken in response to the detection of headlights.



### CAUTION

**Do not adjust the mirror while the vehicle is moving. It may cause the driver to mishandle the vehicle and an accident may occur resulting in personal injuries.**

## SEAT BELTS

### Seat belt precautions

Lexus strongly urges that the driver and passengers in the vehicle be properly restrained at all times with the seat belts provided. Failure to do so could increase the chance of injury and/or the severity of injury in accidents.

**Child.** Use a child restraint system appropriate for the child until the child becomes large enough to properly wear the vehicle's seat belts. See "Child restraint" for details.

If a child is too large for a child restraint system, the child should sit in the rear seat and must be restrained using the vehicle's seat belt. According to accident statistics, the child is safer when properly restrained in the rear seat than in the front seat.

If a child must sit in the front seat, the seat belts should be worn properly. Do not let the child sit on your lap. It does not provide sufficient restraint. If an accident occurs and the seat belts are not worn properly, the force of the rapid inflation of the airbag may cause severe injury to the child.

Do not allow the child to stand up or kneel on either rear or front seats. An unrestrained child could suffer serious injury during emergency braking or a collision.

**Pregnant woman.** Lexus recommends the use of a seat belt. Ask your doctor for specific recommendations. The lap belt should be worn securely and as low as possible over the hips and not on the waist.

**Injured person.** Lexus recommends the use of a seat belt. Depending on the injury, first check with your doctor for specific recommendations.

## COMFORT ADJUSTMENT

---



### CAUTION

Persons should ride in their seats properly wearing their seat belts whenever the vehicle is moving. Otherwise, they are much more likely to suffer serious bodily injury in the event of sudden braking or a collision.

When using the seat belts, observe the following:

- Use the belt for only one person at a time. Do not use a single belt for two or more people – even children.
- Avoid reclining the seatbacks too much. The seat belts provide maximum protection when the seatbacks are in the upright position. (See "Adjusting seatback angle".)
- Be careful not to damage the belt webbing or hardware. Take care that they do not get caught or pinched in the seat or doors.
- Inspect the belt system periodically. Check for cuts, fraying, and loose parts. Damaged parts should be replaced. Do not disassemble or modify the system.

- **Keep the belts clean and dry. If they need cleaning, use a mild soap solution or lukewarm water. Never use bleach, dye, or abrasive cleaners – they may severely weaken the belts. (See "Cleaning the interior" on page 468 for instructions.)**
- **Replace the belt assembly (including bolts) if it has been used in a severe impact. The entire assembly should be replaced even if damage is not obvious.**

### Fastening front and rear outside seat belts

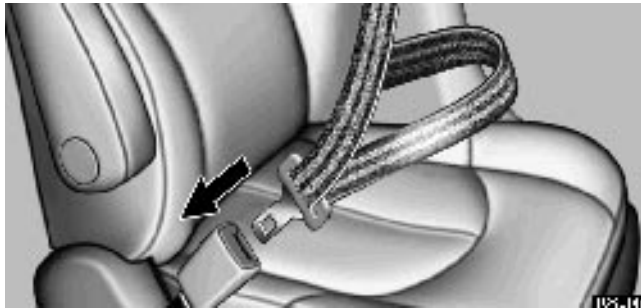

**Adjust the seat as needed and sit up straight and well back in the seat. To fasten your belt, pull it out of the retractor and insert the tab into the buckle.**

You will hear a click when the tab locks into the buckle.

The seat belt length automatically adjusts to your size and the seat position.

## COMFORT ADJUSTMENT

---

The retractor will lock the belt during a sudden stop or on impact. It also may lock if you lean forward too quickly. A slow, easy motion will allow the belt to extend, and you can move around freely.

When a passenger's shoulder belt is completely extended and is then retracted even slightly, the belt is locked in that position and cannot be extended. This feature is used to hold the child restraint system securely. (For details, see "Child restraint" on page 175.) To free the belt again, fully retract the belt and then pull the belt out once more.

If the seat belt cannot be pulled out of the retractor, firmly pull the belt and release it. You will then be able to smoothly pull the belt out of the retractor.



**CAUTION**

- After inserting the tab, make sure the tab and buckle are locked and that the belt is not twisted.
- Do not insert coins, clips, etc. in the buckle as this may prevent you from properly latching the tab and buckle.
- If the seat belt does not function normally, immediately contact your Lexus dealer. Do not use the seat until the seat belt is fixed. It cannot protect an adult occupant or your child from injury.

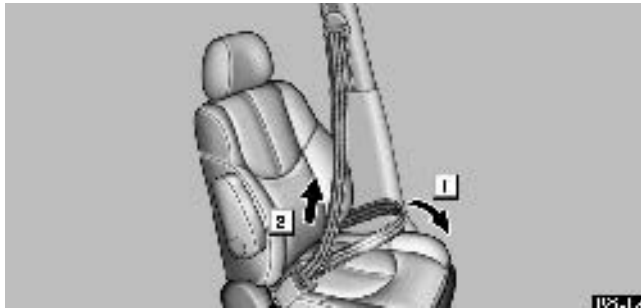

**Adjust the position of the lap and shoulder belts.**

- 1 Position the lap belt as low as possible on your hips – not on your waist.
- 2 Adjust it to a snug fit by pulling the shoulder portion upward through the latch plate.



## COMFORT ADJUSTMENT

---



### CAUTION

- High-positioned lap belts and loose-fitting belts both could cause severe injuries due to sliding under the lap belt during a collision or other unintended result. Keep the lap belt positioned as low on hip as possible.
- For your safety, do not place the shoulder belt under your arm.

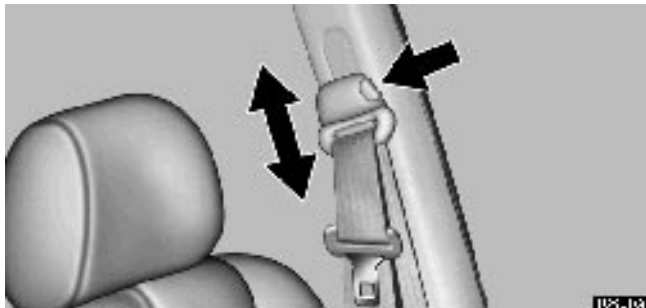

#### ► *Front seat belts only*

#### **Adjust the shoulder anchor position to your size.**

To raise the anchor position, push the anchor up. To lower the anchor position, support the anchor while you push the lock release button then slide the anchor down. After the adjustment, make sure the anchor is locked in position.



**CAUTION**

Always make sure the shoulder belt is positioned across the center of your shoulder. The belt should be kept away from your neck, but not falling off your shoulder. Failure to do so could reduce the amount of protection in an accident and cause severe injuries in a collision.

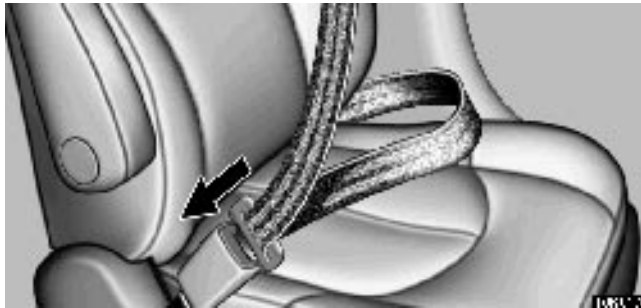

To release the belt, press the buckle release button and allow the belt to retract.

If the belt does not retract smoothly, pull it out and check for kinks or twists. Then make sure it remains untwisted as it retracts.

**Rear center seat belt**

## COMFORT ADJUSTMENT

---

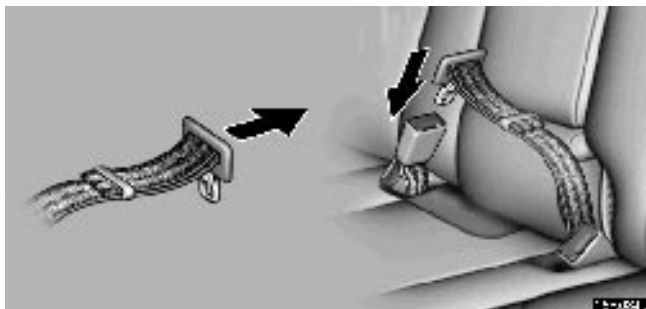

**Sit up straight and well back in the seat. To fasten your belt, insert the tab into the buckle.**

You will hear a click when the tab locks into the buckle.

If the belt is not long enough for you, hold the tab at a right angle to the belt and pull on the tab.



**CAUTION**

- After inserting the tab, make sure the tab and buckle are locked and that the belt is not twisted.
- Do not insert coins, clips, etc. in the buckle as this may prevent you from properly latching the tab and buckle.
- If the seat belt does not function normally, immediately contact your Lexus dealer. Do not use the seat until the seat belt is fixed. It cannot protect an adult occupant or your child from injury.

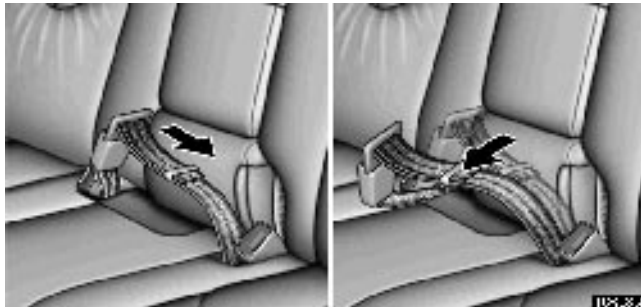

**Remove excess length of the belt and adjust the belt position.**

To shorten the belt, pull the free end of the belt.

Position the lap belt as low as possible on your hips – not on your waist, then adjust it to a snug fit.

## COMFORT ADJUSTMENT

---



### CAUTION

High-positioned and loose-fitting lap belts could cause severe injuries due to sliding under the lap belt during a collision or other unintended result. Keep the lap belt positioned as low on hip as possible.

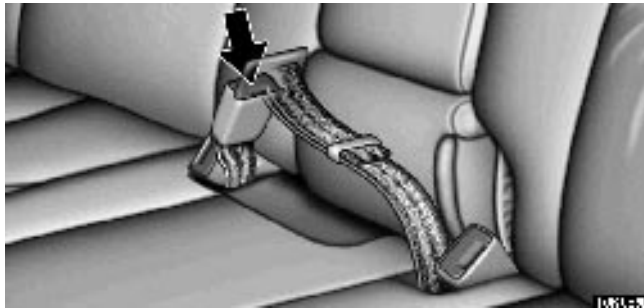

To release the belt, press the buckle release button.

### Seat belt extender

If your seat belts cannot be fastened securely because it is not long enough, a personalized seat belt extender is available from your Lexus dealer free of charge.

Please contact your local Lexus dealer so that the dealer can order the proper required length for the extender. Bring the heaviest coat you expect to wear for proper measurement and selection of length. Additional ordering information is available at your Lexus dealer.



**CAUTION**

When using the seat belt extender, observe the following. Failure to follow these instructions could result in less effectiveness of the seat belt restraint system in case of vehicle accident, increasing the chance of personal injury.

- Never use the seat belt extender if you can fasten the seat belt without it.
- Remember that the extender provided for you may not be safe when used on a different vehicle, or for another person or at a different seating position than the one originally intended for.



## COMFORT ADJUSTMENT

---

**To connect the extender to the seat belt, insert the tab into the seat belt buckle so that the "PRESS" signs on the buckle release buttons of the extender and the seat belt are both facing outward as shown.**

You will hear a click when the tab locks into the buckle.

When releasing the seat belt, press on the buckle release button on the extender, not on the seat belt. This helps prevent damage to the vehicle interior and extender itself.

When not in use, remove the extender and store in the vehicle for future use.



**CAUTION**

- After inserting the tab, make sure the tab and buckle are locked and that the belt is not twisted.
- Do not insert coins, clips, etc. in the buckle as this may prevent you from properly latching the tab and buckle.
- If the seat belt does not function normally, immediately contact your Lexus dealer. Do not use the seat until the seat belt is fixed. It cannot protect an adult occupant or your child from injury.



## COMFORT ADJUSTMENT

---

### **SUPPLEMENTAL RESTRAINT SYSTEM (SRS)**

The Supplemental Restraint System (SRS) consists of driver and front passenger airbags, side airbags and seat belt pretensioners. The combination of these 3 systems is designed to provide further protection for the driver and front passenger when added to the primary protection provided by the seat belts.

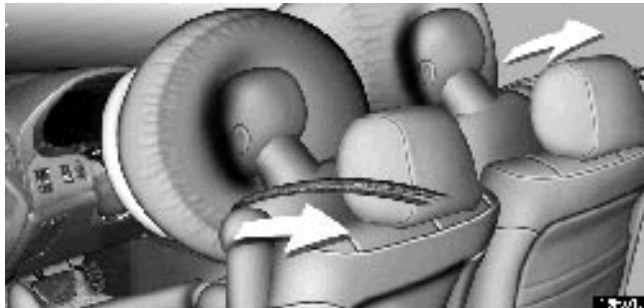

► *Driver and front passenger airbags, and seat belt pretensioners*

**Driver and front passenger airbags:**

**In response to a severe frontal impact, the driver and front passenger airbags work together with the seat belts to help preventing or reduce injury by inflating, in order to decrease the likelihood of the driver's or front passenger's heads or chests from directly hitting the steering wheel or dashboard.**

**Seat belt pretensioners:**

**In response to a severe frontal impact, the seat belts are quickly drawn back in by the retractors so that the belts snugly restrain the driver and front passenger.**

The front passenger airbag is activated even with no passenger in the front seat.

The seat belt pretensioners are activated even with no passenger in the front seat.

Be sure to wear your seat belt.

## COMFORT ADJUSTMENT

---



### CAUTION

The driver or front passenger too close to the steering wheel or dashboard during airbag deployment can be killed or seriously injured. Lexus strongly recommends that:

- The driver sit as far back as possible from the steering wheel while still maintaining control of the vehicle.
- The front passenger sit as far back as possible from the dashboard.
- All vehicle occupants be properly restrained using the available seat belts.

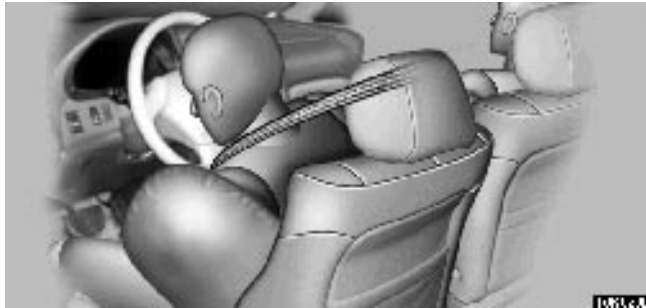

► *Side airbags*

**Side airbags:**

**In response to a severe side impact, the side airbag for the driver or front passenger works together with the seat belt to help preventing or reducing injury by inflating, in order to decrease the impact mainly on the driver or front passenger's chest.**

The side airbag on the passenger seat is activated even with no passenger in the front seat.

Be sure to wear your seat belt.

## COMFORT ADJUSTMENT

---



### CAUTION

SRS side airbags inflate with considerable force. To avoid potential death or serious injury during inflation of a side airbag, Lexus strongly recommends that the driver and front passenger;

- Wear their seat belt.
- Remain properly seated with their back against the seat at all times.



The indicator comes on when the ignition key is turned to the "ACC" or "ON" position. It goes off after about 6 seconds. This means the SRS is operating properly.

The SRS warning light system monitors the airbag sensor assemblies, front airbag sensors, inflators, seat belt pretensioners, warning light, interconnecting wiring and power sources. (For details, see "Service reminder indicators and warning buzzers" on page 57 for instructions.)

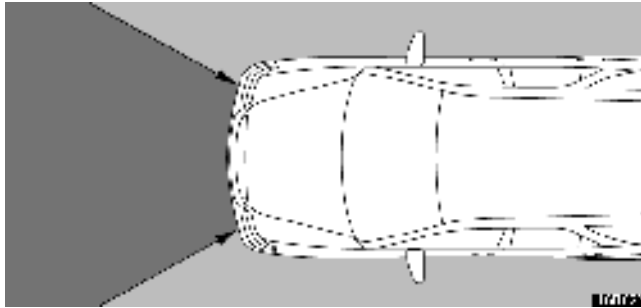

**The driver and front passenger airbags and seat belt pretensioners are designed to activate in response to a severe frontal impact within the shaded area between the arrows in the illustration.**

There may be the case that the driver and passenger airbags and seat belt pretensioners will not activate with such an impact in which the occupant wearing the seat belt correctly would not get serious injury.

The driver and front passenger airbags and seat belt pretensioners will work if the severity of the impact is above the designed threshold level, comparable to an approximate 25 km/h (15 mph) collision when impacting straight into a fixed barrier that does not move or deform.

If the severity of the impact is below the above threshold level, the driver and front passenger airbags and seat belt pretensioners may not work.

However, this threshold velocity will be considerably higher if the vehicle strikes an object, such as a parked vehicle or sign pole, which can move or deform on impact, or if it is involved in an underride collision (e.g. a collision in which the nose of the vehicle "underrides", or goes under, the bed of a truck, etc.).

It is possible with collision severity at the marginal level of driver and passenger airbag sensor detection and activation that only one of your vehicle's driver and front passenger airbags and seat belt pretensioners will work.

For the safety of all occupants, be sure to always wear seat belts.

## COMFORT ADJUSTMENT

---

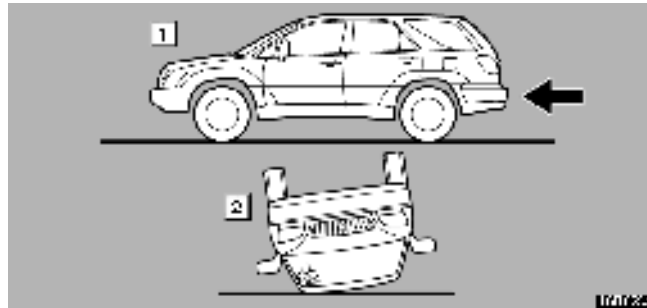

- ▶ **1** *Collision from the rear*
- 2** *Vehicle rollover*

**The driver and front passenger airbags and seat belt pretensioners are not designed to inflate if the vehicle is subjected to a rear impact, if it rolls over, or if it is involved in a low-speed frontal collision.**

**The side airbags are designed to inflate when the passenger compartment gets a severe impact from the side.**

The side airbags may rather not to activate in the impact in which the occupant wearing the seat belt correctly would not get serious injury.

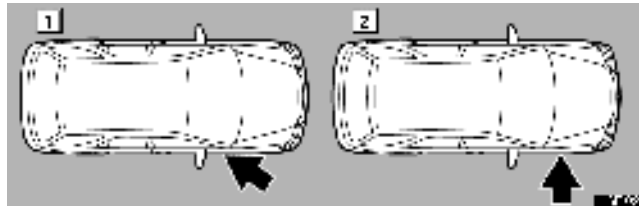

- ▶ **1** Collision from the side at an angle
- ▶ **2** Collision from the side to the vehicle body other than the passenger compartment

The side airbags may not inflate if the vehicle is subjected to a collision from the side at an angle, or a collision to the side of the vehicle body other than the passenger compartment, which impact is not severe enough for the passenger compartment.

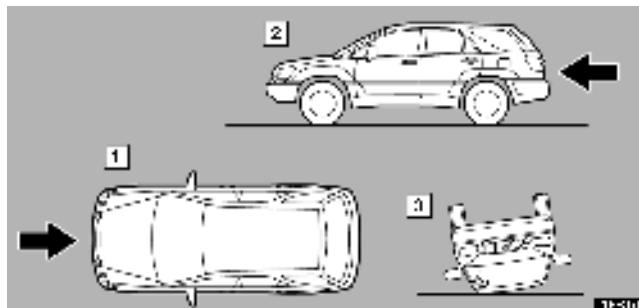



## COMFORT ADJUSTMENT

---

- ▶ **1** *Collision from the front*
- 2** *Collision from the rear*
- 3** *Vehicle rollover*

The SRS side airbags are not designed to inflate if the vehicle is subjected to a front or rear impact, if it rolls over, or if it is involved in a low-speed side collision.

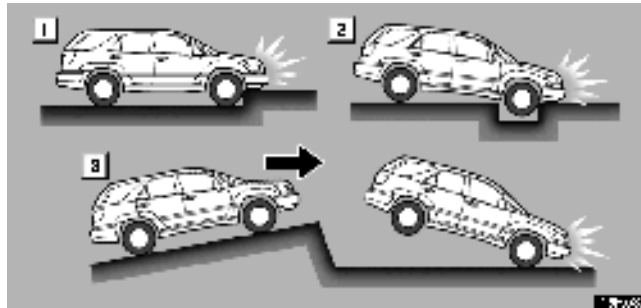

- ▶ **1** *Hitting a curb, edge of pavement or hard material*
- 2** *Falling into or jumping over a deep hole*
- 3** *Landing hard or vehicle falling*

The SRS may operate if a serious impact occurs to the underside of your vehicle. Some examples are shown in the illustration.

## COMFORT ADJUSTMENT

---

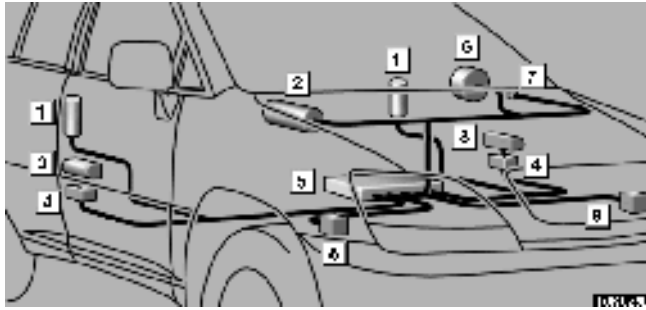

- ▶ **1** Side airbag module (airbag and inflator)
- 2** Airbag module for front passenger (airbag and inflator)
- 3** Seat belt pretensioner
- 4** Side airbag sensor assembly
- 5** Airbag sensor assembly
- 6** Airbag module for driver (airbag and inflator)
- 7** SRS warning light
- 8** Front airbag sensor

The SRS airbag sensor assemblies consist of a safing sensor and driver and front passenger airbag sensor.

In a severe frontal impact, the driver and front passenger airbag sensor detects deceleration and the system triggers the front airbag inflators and seat belt pretensioners. In a severe side impact, the side airbag sensor triggers the side airbag inflator. Then a chemical reaction in the inflators momentarily fills the airbags with non-toxic gas to help restrain the forward or lateral motion of the occupants. Then the inflators fill the airbags and the seat belts are quickly drawn back in by the retractors to help restrain forward motion of the occupants.

When the SRS operates, it produces a fairly loud noise and release some smoke and residue along with non-toxic gas. This does not indicate a fire. This gas is normally harmless, however, for those who have delicate skin, it may cause minor skin irritation. Be sure to wash off any residue as soon as possible to prevent minor skin irritation.

Deployment of the airbags happens in a fraction of a second, so the airbags must inflate with considerable force. While the system is designed to reduce serious injuries, it may also cause minor burns or abrasions and swellings.

Parts of the airbag module (steering wheel hub, dashboard, front seats) may be hot for several minutes, but the airbags themselves will not be hot. The airbags are designed to inflate only once.

A crash severe enough to inflate the driver and front passenger airbags may break the windshield as the vehicle buckles. In vehicles with a front passenger airbag, the windshield may also be damaged by absorbing some of the force of the inflating airbag.

## COMFORT ADJUSTMENT

---



### CAUTION

- The SRS is designed only as a supplement to the primary protection of the driver side and front passenger side seat belt systems. The front seat occupants can be killed or seriously injured by an inflating airbag if they do not wear the available seat belts. During sudden braking just before a collision, an unrestrained driver or front passenger can move forward into direct contact with or close proximity to the airbag which may then deploy during the collision. To obtain maximum protection in an accident, the driver and all passengers in the vehicle must wear their seat belts. Wearing a seat belt during an accident reduces the chances of death or serious injuries or being thrown out of the vehicle. For instructions and precautions concerning the seat belt system, see "Seat belts" on page 139.
- Improperly seated and/or restrained infants and children can be killed or seriously injured by a deploying airbag. An infant or child who is too small to use a seat belt should be properly secured using a child restraint system. Lexus strongly recommends that all infants and children be placed in the rear seat of the vehicle and properly restrained. The rear seat is the safest for infants and children. For instructions concerning the installation of a child restraint system, see "Child restraint" on page 175 .

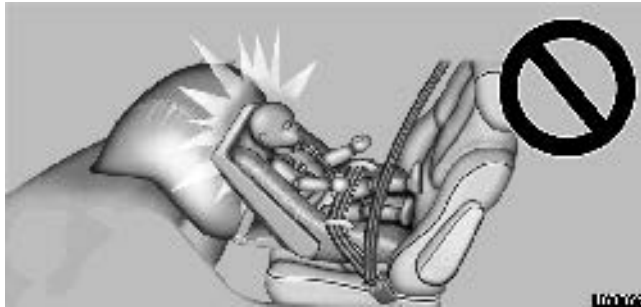

- Never put a rear-facing child restraint system on the front seat because the force of the rapid inflation of the front passenger airbag can cause death or serious injury to the child.

## COMFORT ADJUSTMENT

---



► *Move seat fully back*

- A forward-facing child restraint system should be allowed to put on the front seat only when it is unavoidable. Always move the seat as far back as possible, because the force of a deploying airbag could cause death or serious injury to the child. Do not allow the child to lean against the front door or around the front door even if the child is seated in a child restraint system. It is dangerous if the side airbag inflates, and the impact could cause death or serious injury to the child. For instructions concerning the installation of a child restraint system, see "Child restraint" on page 175.

## COMFORT ADJUSTMENT

---

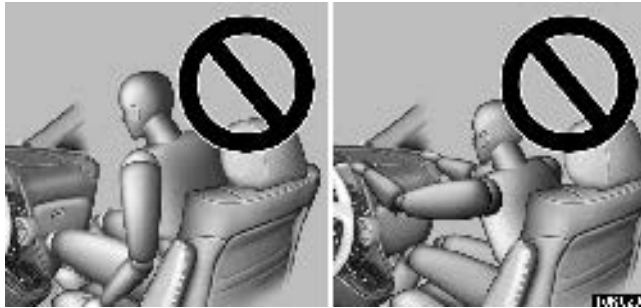

- Do not sit on the edge of the seat or lean over the dashboard when the vehicle is in use. The airbags inflate with considerable speed and force; you may be killed or seriously injured. Sit up straight and well back in the seat, and always use your seat belt.



## COMFORT ADJUSTMENT

---



- Do not lean against the front door when the vehicle is in use. The side airbag inflates with considerable speed and force; you may be killed or seriously injured.
- Do not apply excessive weight to the outer side of the front seats on vehicles with side airbags.
- The child head should not be leaned against the vicinity of the part where the side airbag activates.

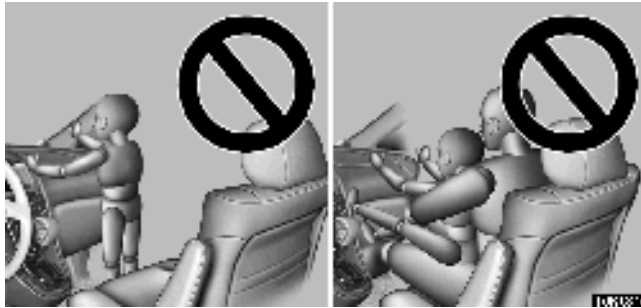

- Do not allow a child to stand up, or to kneel on the front passenger seat. The airbag inflates with considerable speed and force; the child may be killed or seriously injured.
- Do not hold a child on your lap or in your arms. Use a child restraint system in the rear seat. For instructions concerning the installation of a child restraint system, see "Child restraint" on page 175.

## COMFORT ADJUSTMENT

---



- Do not put objects or your pets on or in front of the dashboard or steering wheel pad that houses the driver and front passenger airbag system. They might restrict inflation or cause death or serious injury as they are projected rearward by the force of the deploying airbags. Likewise, the driver and front passenger should not hold things in their arms or on their knees.

## COMFORT ADJUSTMENT

---



## COMFORT ADJUSTMENT

---

- Do not attach a cup holder or any other device on or around the door. When the side airbag inflates, the cup holder or any other device will be thrown with great force, or the side airbag may not activate correctly, resulting in death or serious injury. Likewise, the driver and front passenger should not hold things in their arms or on their knees.

- Do not use accessories for the seats which cover the parts where the side airbags should inflate. Such accessories may prevent the side airbags from activating correctly, causing death or serious injury.

- Do not modify or remove any wiring. Do not modify, remove, strike or open any components, such as the steering wheel pad, steering wheel, column cover, front passenger airbag cover, front seats, airbag sensor assembly or seat belt assemblies. Doing any of these may cause sudden SRS operation or disable the system, which could result in death or serious injury.

- Do not modify or replace the seats or surface of the front seats with side airbags. Such changes may disable the system or cause the side airbags to inflate, resulting in death or serious injury. Consult your Lexus dealer.

Failure to follow these instructions can result in death or serious injuries.

### *NOTICE*

*Do not perform any of the following changes without consulting your Lexus dealer. Such changes can interfere with proper operation of the SRS in some cases.*

- *Installation of electronic items such as a mobile two-way radio, cassette tape player or compact disc player.*
- *Modification of the suspension system.*
- *Modification of the front end structure and side structure of the passenger compartment.*
- *Attachment of a grille guard (bull bar, kangaroo bar, etc.), snow plow, winches or any other equipment to the front end.*
- *Repairs made on or near the front fenders, front end structure, console, steering column, steering wheel, dashboard near the front passenger airbag, front seats or seat belt assembly.*

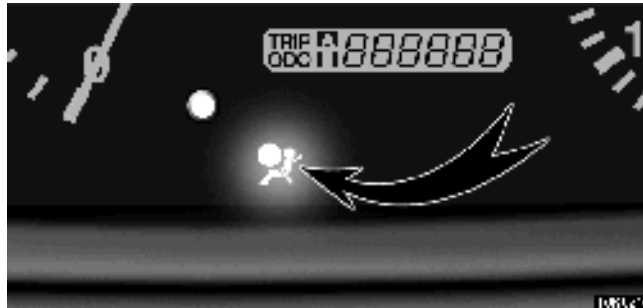

This SRS has an indicator to inform the driver of operating problems. If either of the following conditions occurs, this indicates a malfunction of the airbags and/or seat belt pretensioners. Even if the seat belt pretensioners should fail, the seat belts will operate conventionally. Contact your Lexus dealer as soon as possible to service the vehicle.

- The light does not come on as described above.
- The light stays on or flashes.
- The light comes on or starts flashing while driving.

If the light stays on, it indicates that the driver and front passenger airbags fail. If the light flashes, the side airbags and/or seat belt pretensioners fail.

## COMFORT ADJUSTMENT

---



In the following cases, contact your Lexus dealer as soon as possible:

- Any of the SRS airbags have been inflated.
- If either front seat belt does not retract or cannot be pulled out due to a malfunction or activation of the pretensioner.

- The front seat belt retractor assembly or surrounding area has been damaged.
- The front part of the vehicle and portion of the doors (shaded in the illustration) were involved in an accident that did not cause the SRS to work.
- The surface of the seats with the side airbags or the pad section of the steering wheel or front passenger airbag cover (shaded in the illustration) is scratched, cracked, or otherwise damaged.

## CHILD RESTRAINT

### Child restraint precautions

**Lexus strongly urges the use of child restraint systems for children small enough to use them.**

The laws of all fifty states in the U.S.A. and Canada now require the use of a child restraint system.

Your vehicle conforms to SAE J1819.

If a child is too large for a child restraint system, the child should sit in the rear seat and must be restrained using the vehicle's seat belt. See "Seat belts" on page 139 for details.



## COMFORT ADJUSTMENT

---



### CAUTION

- For effective protection in automobile accidents and sudden stops, children must be properly restrained using a seat belt or child restraint depending on age and size. Holding a child in your arms is not a substitute for a child restraint system. In an accident, the child can be crushed against the windshield, or between you and the vehicle's interior if you are unrestrained.
- Lexus strongly urges use of a proper child restraint which conforms to the size of the child and is put on the rear seat. According to accident statistics, the child is safer when properly restrained in the rear seat than in the front seat.

- **Never put a rear-facing child restraint system on the front seat. In the event of an accident, the force of the rapid inflation of the airbag can cause death or serious injury if a rear-facing child restraint system is put on the front seat.**
- **Unless it is unavoidable, do not put a forward-facing child restraint system on the front seat.**
- **A forward-facing child restraint system should be put on the front seat only when it is unavoidable. Always move the seat as far back as possible, because the force of a deploying airbag could cause death or serious injury to the child.**
- **Make sure you have complied with all installation instructions provided by the child restraint manufacturer and that the system is properly secured. Do not allow the child to lean over the front door or around the front door even if the child is seated in a child restraint system. It is dangerous if the side airbag inflates, and the impact could cause death or serious injury to the child.**

## COMFORT ADJUSTMENT

---

### **Child restraint system**

**A child restraint system for a small child or baby must itself be properly restrained on the seat with either the lap belt or the lap portion of the lap/shoulder belt. You must carefully consult the manufacturer's instructions which accompany by your child restraint system.**

To provide proper restraint, use a child restraint system following the manufacturer's instructions about the appropriate age and size of the child for the restraint system.

Install the child restraint system correctly following the instructions provided by its manufacturer of the system. General directions are also provided under the following illustrations.

The child restraint system should be installed on the rear seat. According to accident statistics, the child is safer when properly restrained in the rear seat than in the front seat.



**CAUTION**

- Never put a rear-facing child restraint system on the front seat. In the event of an accident, the force of the rapid inflation of the airbag can cause death or serious injury if a rear-facing child restraint system is put on the front seat.
- Unless it is unavoidable, do not put a forward-facing child restraint system on the front seat.
- A forward-facing child restraint system should be put on the front seat only when it is unavoidable. Always move the seat as far back as possible, because the force of a deploying airbag could cause death or serious injury to the child. Do not allow the child to lean over the front door or around the front door even if the child is seated in a child restraint system. It is dangerous if the side airbag inflates, and the impact could cause death or serious injury to the child.
- After installing the child restraint system, make sure it is secured in place according to the manufacturer's instructions. If it is not restrained securely, it may cause death or serious injury to the child in the event of a sudden stop or accident.

## COMFORT ADJUSTMENT

---

When not using the child restraint system, keep it secured with the seat belt or place it somewhere other than in the passenger compartment. This will prevent it from injuring passengers in the event of a sudden stop or accident.

Your vehicle has anchors for securing the top strap of a child restraint system. The anchor nuts are welded beneath the sheet metal to permit installation of an anchor bracket for a child restraint system.

To install an anchor bracket, use an 8 mm X 30 mm X 1.25 mm coarse thread metric bolt and a 15 mm (0.6 in.) spacer. Note that the bolts accompanying many child restraint systems are not metric. You can damage the anchor nuts on your vehicle if you force bolts with different thread into the anchor nuts.

For instructions about how to install the anchor bracket, see "Top strap anchors and locations".

If your child restraint system does not provide any of the necessary parts, you can purchase the following items from your Lexus dealer.

- CRS installation kit (Part No. 04731-22012)  
– contains 1 bolt, 3 types of spacer and 1 locking clip.
- Bolt (Part No. 91511-60830)

### Types of child restraint system

Child restraint systems are classified into the following 3 types depending on the child's age and size.

- (A) Infant seat
- (B) Convertible seat
- (C) Booster seat

Install the child restraint system following the instructions provided by its manufacturer.

#### (A) Infant seat

## COMFORT ADJUSTMENT

---

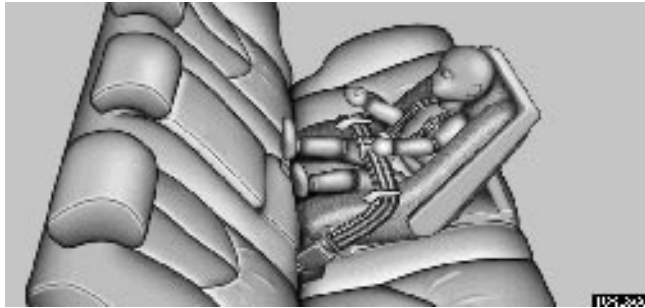

## COMFORT ADJUSTMENT

---

(B) Convertible seat

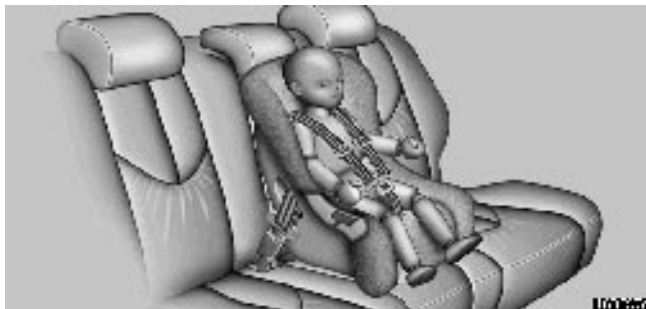

(C) Booster seat



**INSTALLATION WITH 2-POINT TYPE SEAT BELT**

**(A) Infant seat installation**

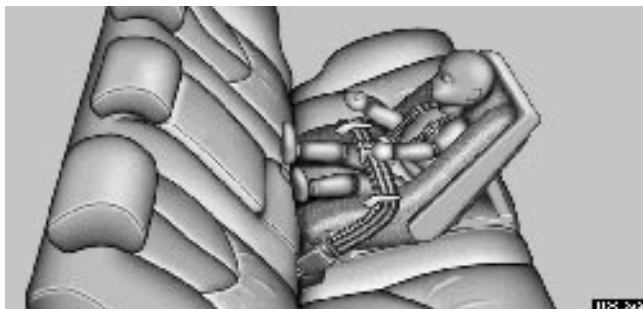

An infant seat is used in rear-facing position only.



## COMFORT ADJUSTMENT

---

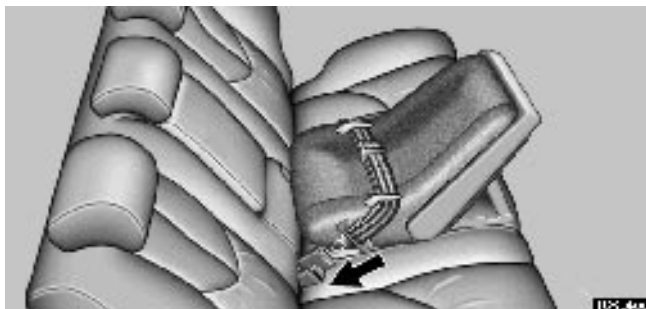

1. Run the center lap belt through or around the infant seat following the instructions provided by its manufacturer and insert the tab into the buckle taking care not to twist the lap belt.



**CAUTION**

- After inserting the tab, make sure the tab and buckle are locked and that the lap belt is not twisted.
- Do not insert coins, clips, etc. in the buckle as this may prevent you from properly latching the tab and buckle.
- If the seat belt does not function normally, immediately contact your Lexus dealer. Do not use the seat until the seat belt is fixed. It cannot protect your child from injury.

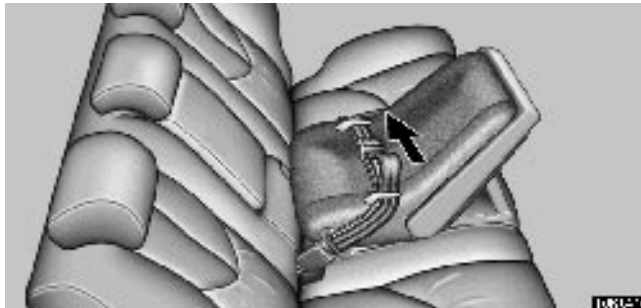

2. While pressing the infant seat firmly against the seat cushion and seatback, tighten the lap belt by pulling its free end to hold the infant seat securely.

## COMFORT ADJUSTMENT

---

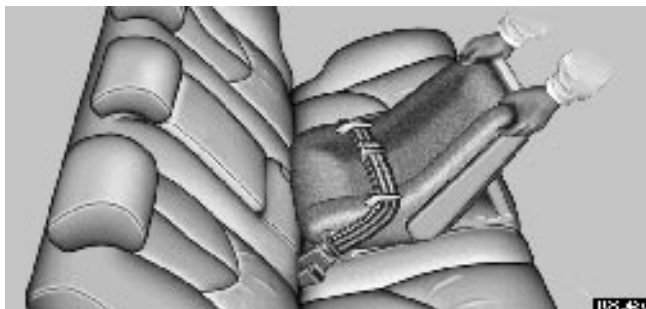

### CAUTION

**Push and pull the child restraint system in different directions to be sure it is secure. Follow all the installation instructions provided by its manufacturer.**



## COMFORT ADJUSTMENT

---

3. To remove the infant seat, press the buckle–release button.

**(B) Convertible seat installation**



A convertible seat is used in forward-facing and rear-facing positions depending on the age and size of the child. When installing, follow the manufacturer's instructions about the appropriate age and size of the child as well as directions for installing a child restraint system.

## COMFORT ADJUSTMENT

---



1. Run the center lap belt through or around the convertible seat following the instructions provided by its manufacturer and insert the tab into the buckle taking care not to twist the lap belt.



**CAUTION**

- After inserting the tab, make sure the tab and buckle are locked and that the lap belt is not twisted.
- Do not insert coins, clips, etc. in the buckle as this may prevent you from properly latching the tab and buckle.
- If the seat belt does not function normally, immediately contact your Lexus dealer. Do not use the seat until the seat belt is fixed. It cannot protect your child from injury.



2. While pressing the convertible seat firmly against the seat cushion and seatback, tighten the lap belt by pulling its free end to hold the convertible seat securely.

## COMFORT ADJUSTMENT

---



### CAUTION

**Push and pull the child restraint system in different directions to be sure it is secure. Follow all the installation instructions provided by its manufacturer.**

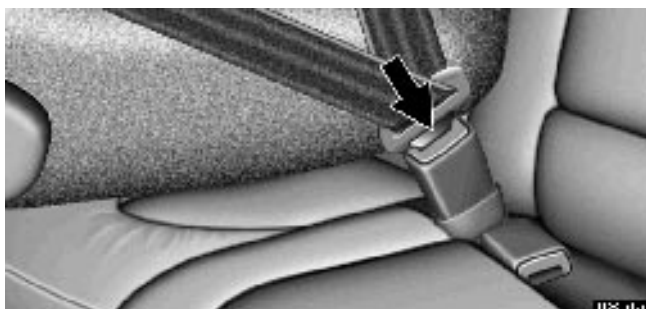

## COMFORT ADJUSTMENT

---

3. To remove the convertible seat, press the buckle-release button.

### INSTALLATION WITH 3-POINT TYPE SEAT BELT

#### (A) Infant seat installation

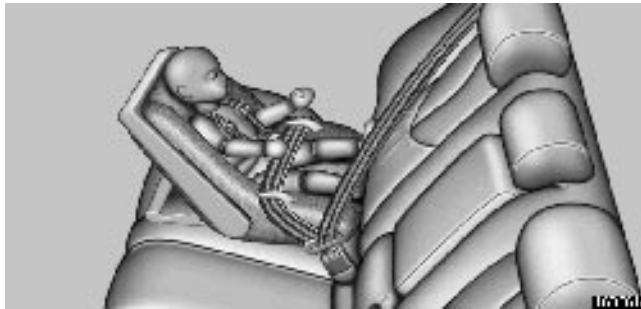

An infant seat is used in rear-facing position only.



## COMFORT ADJUSTMENT

---

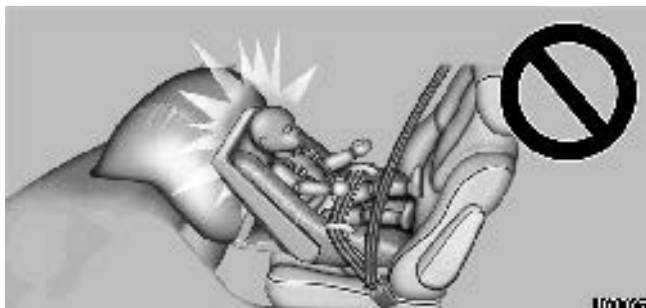

 **CAUTION**

Never put a rear-facing child restraint system in the front seat because the force of the rapid inflation of the front passenger airbag can cause death or serious injury to the child.



## COMFORT ADJUSTMENT

---

1. Run the lap and shoulder belt through or around the infant seat following the instructions provided by its manufacturer and inserting the tab into the buckle taking care not to twist the belt. Keep the lap portion of the belt tight.



### CAUTION

- After inserting the tab, make sure the tab and buckle are locked and that the lap and shoulder portions of the belt are not twisted.
- Do not insert coins, clips, etc. in the buckle as this may prevent you from properly latching the tab and buckle.
- If the seat belt does not function normally, immediately contact your Lexus dealer. Do not use the seat until the seat belt is fixed. It cannot protect your child from injury.



## **COMFORT ADJUSTMENT**

---

2. Fully extend the shoulder belt to put it in the lock mode. When the belt is then retracted even slightly, it cannot be extended.

To hold the infant seat securely, make sure the belt is in the lock mode before letting the belt retract.

## COMFORT ADJUSTMENT

---

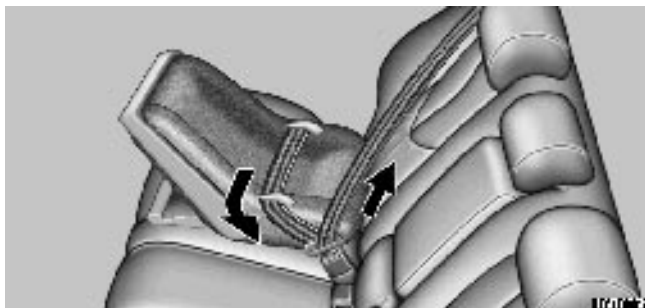

3. While pressing the infant seat firmly against the seat cushion and seatback, let the shoulder belt retract as far as it will go to hold the infant seat securely.

## COMFORT ADJUSTMENT

---



### CAUTION

**Push and pull the child restraint system in different directions to be sure it is secure. Follow all the installation instructions provided by its manufacturer.**

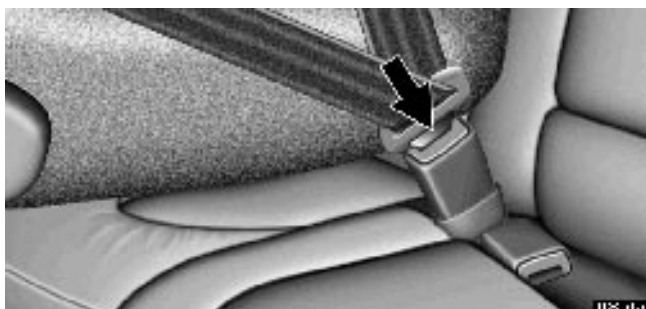

4. To remove the infant seat, press the buckle–release button and allow the belt to retract completely. The belt will move freely again and be ready to work for an adult or older child passenger.

**(B) Convertible seat installation**



A convertible seat is used in forward–facing and rear–facing positions depending on the age and size of the child. When installing, follow the manufacturer’s instructions about the appropriate age and size of the child as well as directions for installing a child restraint system.

## COMFORT ADJUSTMENT

---

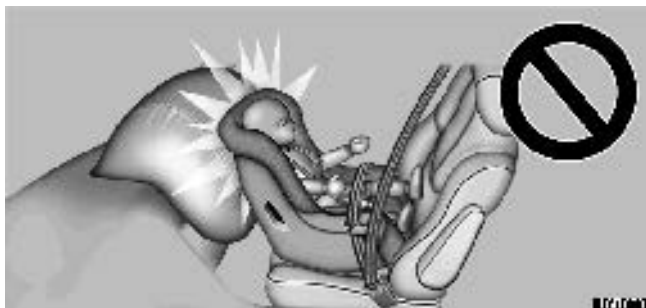

### CAUTION

- Never put a rear-facing child restraint system in the front seat because the force of the rapid inflation of the front passenger airbag can cause death or serious injury to the child.

## COMFORT ADJUSTMENT

---



► *Move seat fully back*

- A forward-facing child restraint system should be put on the front seat only when it is unavoidable. Always move the seat as far back as possible, because the force of a deploying airbag could cause death or serious injury to the child. Do not allow the child to lean over the front door or around the front door even if the child is seated in a child restraint system. It is dangerous if the side airbag inflates, and the impact could cause death or serious injury to the child.



## COMFORT ADJUSTMENT

---

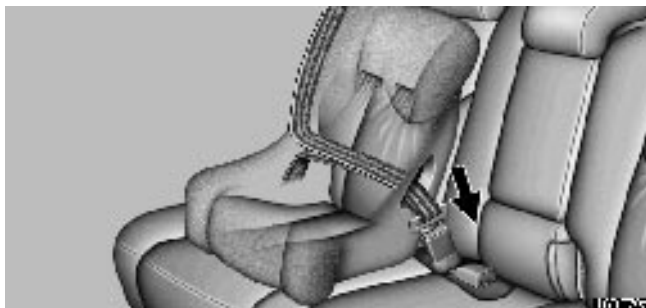

1. Run the lap and shoulder belt through or around the convertible seat following the instructions provided by its manufacturer and inserting the tab into the buckle taking care not to twist the belt. Keep the lap portion of the belt tight.



**CAUTION**

- After inserting the tab, make sure the tab and buckle are locked and that the lap and shoulder portions of the belt are not twisted.
- Do not insert coins, clips, etc. in the buckle as this may prevent you from properly latching the tab and buckle.
- If the seat belt does not function normally, immediately contact your Lexus dealer. Do not use the seat until the seat belt is fixed. It cannot protect your child from injury.

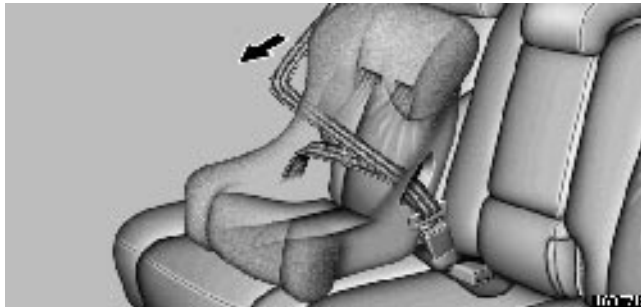

2. Fully extend the shoulder belt to put it in the lock mode. When the belt is then retracted slightly, it cannot be extended.

To hold the convertible seat securely, make sure the belt is in the lock mode before letting the belt retract.

## COMFORT ADJUSTMENT

---

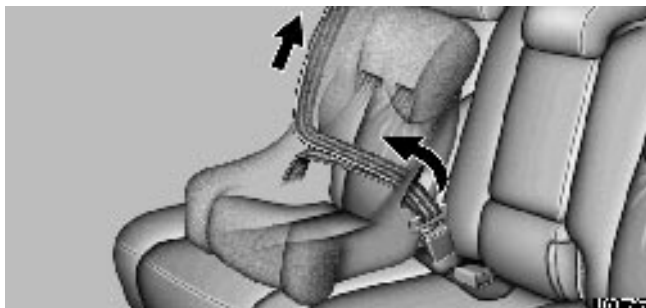

3. While pressing the convertible seat firmly against the seat cushion and seatback, let the shoulder belt retract as far as it will go to hold the convertible seat securely.

## COMFORT ADJUSTMENT

---



### CAUTION

**Push and pull the child restraint system in different directions to be sure it is secure. Follow all the installation instructions provided by its manufacturer.**

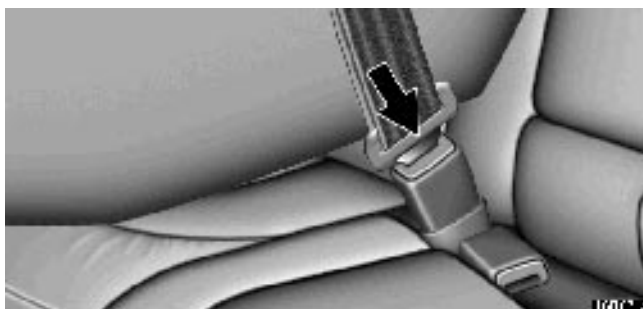

## COMFORT ADJUSTMENT

---

4. To remove the convertible seat, press the buckle-release button and allow the belt to retract completely. The belt will move freely again and be ready to work for an adult or older child passenger.



A booster seat is used in forward-facing position only.

### (C) Booster seat installation

## COMFORT ADJUSTMENT

---



► *Move seat fully back*

## COMFORT ADJUSTMENT

---



### CAUTION

A forward-facing child restraint system should be put on the front seat only when it is unavoidable. Always move the seat as far back as possible, because the force of a deploying airbag could cause death or serious injury to the child. Do not allow the child to lean over the front door or around the front door even if the child is seated in a child restraint system. It is dangerous if the side airbag inflates, and the impact could cause death or serious injury to the child.

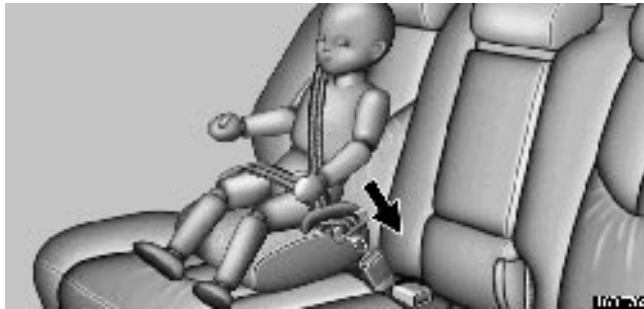

1. Sit the child on a booster seat. Run the lap and shoulder belt through or around the booster seat and child following the instructions provided by its manufacturer and insert the tab into the buckle.

Make sure the shoulder belt is correctly across the child's shoulder and that the lap belt is positioned as low as possible on child's hips. See "Seat belts" on page 139 for details.



**CAUTION**

- Always make sure the shoulder belt is positioned across the center of child's shoulder. The belt should be kept away from child's neck, but not falling off child's shoulder. Failure to do so could reduce the amount of protection in an accident and cause serious injuries in a collision.
- High-positioned lap belts and loose-fitting belts both could cause serious injuries due to sliding under the lap belt during a collision or other unintended result. Keep the lap belt positioned as low on hip as possible.
- For child's safety, do not place the shoulder belt under child's arm.
- After inserting the tab, make sure the tab and buckle are locked and that the lap and shoulder portions of the belt are not twisted.
- Do not insert coins, clips, etc. in the buckle as this may prevent you from properly latching the tab and buckle.
- If the seat belt does not function normally, immediately contact your Lexus dealer. Do not use the seat until the seat belt is fixed. It cannot protect your child from injury.



## COMFORT ADJUSTMENT

---

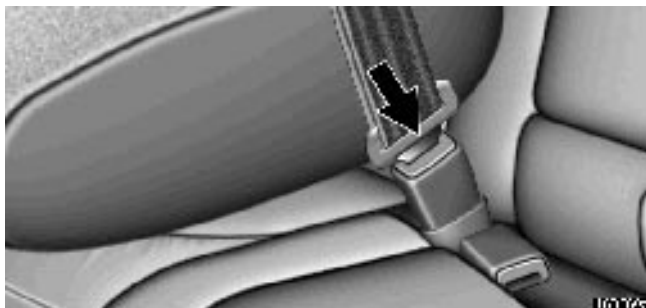

2. To remove the child restraint system, press the buckle-release button and allow the belt to retract.

**Top strap anchors and locations**

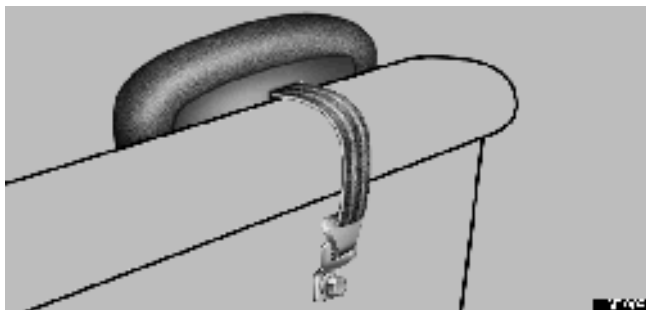

**If your child restraint system requires the use of a top strap, latch the hook onto the anchor bracket and tighten the top strap.**

See the following instructions to install the anchor bracket.

## COMFORT ADJUSTMENT

---

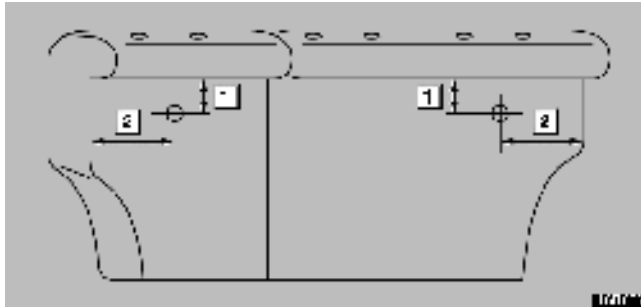

► **1** 113 mm (4.4 in.) **2** 302 mm (11.9 in.)

1. Run your fingers from the rear of the seatback to locate the holes underneath it in the positions shown above.
2. Make a hole in the covering directly above the hole in the rear of the seatback.

## COMFORT ADJUSTMENT

---

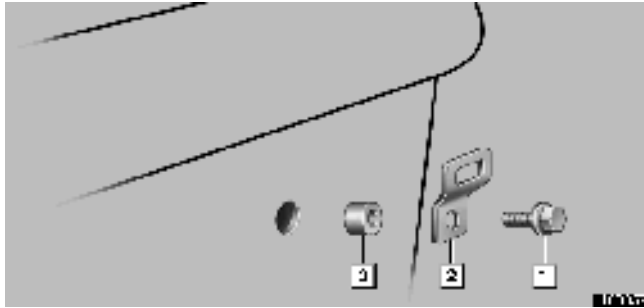

► **1** Bolt **2** Anchor bracket **3** Spacer

3. Insert a 5 mm (0.2 in.) spacer, and tighten down the anchor bracket for your child restraint system with a bolt. Torque the bolt to 16.5 – 24.7 N·m (1.68 – 2.52 kgf·m, 12.2 – 18.2 ft·lbf.).

This model sold in Canada is provided with a bracket set in the glove box, designed for use with either of the 2 anchor locations shown in the illustration.

## DRIVING POSITION MEMORY SYSTEM

The micro computer can memorize the position of the driver's seat. Two different driving position profiles can be entered into the computer's memory.

Recording a driving position in the computer's memory can only be done when the ignition key is in the "ON" position and the selector lever is in the "P" position.

### Setting a driving position

## COMFORT ADJUSTMENT

---



- 1. Adjust the driver's seat to the desired position.**
- 2. While pushing the "SET" button, push button "1" or "2" until the signal beeps.**

The beep sound means that the positions are recorded in the computer's memory.

By repeating these two steps and pressing the remaining button, the driving position for another driver can be recorded.

To set a new memorized position, select the desired position and perform step 2. The previous memory will be erased and the new position will be set.

To make only slight changes to an already memorized position, the easiest way is to first activate the memorized position, then make the desired changes and perform step 2 above.

## COMFORT ADJUSTMENT

---

### Activating a memorized position



When you push button "1" or "2", the driving position will be automatically adjusted to the position recorded for that button.

### Conditions for memorized position activation

- Ignition key "ON" and selector lever in "P" position  
All parts of the memorized positions can be activated.  
However, if the brake pedal is being depressed, the seat position will not change.
- Key not in ignition switch and within 30 seconds of opening driver's door.  
The memorized position can be activated.

If any driving position memory switch is pushed while one of the memorized driving position profiles is being activated, the operation will stop.

To activate the system, push the desired button ("1" or "2") again.

The driving position memory control system cannot be operated while the vehicle is moving.

If the vehicle's battery is disconnected, the computer's memory will be erased and the memorized positions will have to be set again.

## COMFORT ADJUSTMENT

---



### CAUTION

- Do not start the vehicle while the adjustments are being made.
- Take care not to select the wrong button, or the seat could strike the rear passenger or hit your body against the steering wheel. If this happens, you can stop the movement by pressing another driving position memory switch, or depressing the brake pedal.

# *SECTION 1 - 7*

---

## **INSTRUMENTS AND CONTROLS**

### **Theft deterrent**

Theft deterrent system .....	216
Theft prevention labels .....	219



## THEFT DETERRENT

---

### THEFT DETERRENT SYSTEM

To deter theft of the vehicle, this system is designed to give an alarm if any of the doors or hood is forcibly unlocked or the battery terminal is disconnected and then reconnected while the vehicle is locked.\*

*NOTE: \*The system operating condition can be changed. Ask your Lexus dealer for details.*

The alarm blows the horn intermittently and flashes the headlights, tail lights and other exterior lights.



### Setting the system

**1. Turn the ignition key to the "LOCK" position and remove it.**

The indicator light flashes by means of the engine immobiliser system.

**2. Close and lock all the doors and hood using an ignition key or wireless remote control.**

If you lock them with wireless remote control, the turn signals flash once.\*

*NOTE: \*The turn signals can be set not to flash. Ask your Lexus dealer for details.*

The flashing indicator light will change to stay on when all the doors and hood are closed and locked.

**3. After 30 seconds, the indicator starts flashing and the system is set.**

### Cancelling the system

**When you unlock any door using an ignition key or wireless remote control, the system is cancelled.**

If you unlock any door with wireless remote control, the turn signals flash twice.\*

*NOTE: \*The turn signals can be set not to flash. Ask your Lexus dealer for details.*

### Activating the system

The alarm sounds for 60 seconds if any of the following are operated:

- Unlocking any door without using an ignition key or wireless remote control.
- Opening the hood forcibly.
- Reconnecting the battery.

## THEFT DETERRENT

---

If any door is unlocked and the ignition key is not in the ignition switch during the alarm sounding, its door is automatically locked.

**To stop the alarm:** Use either of the following methods.

- Unlock the door using an ignition key or wireless remote control.
- Turn the ignition switch on.

### Testing the system

**1. Open all the windows.**

**2. Set the system as described above.**

The front doors should be locked with the ignition key or wireless remote control. Be sure to wait until the indicator light starts flashing.

**3. Unlock one of the doors from the inside.**

The system should activate the alarm.

**4. Unlock any of the doors with a key or the wireless remote control to cancel the system.**

**5. Repeat this operation for the other doors and hood.**

When testing the hood, also check that the system is activated when the battery terminal is disconnected and then reconnected.

If the system does not work properly, have it checked by your Lexus dealer.

### **NOTICE**

*Disconnecting the battery may result in the erasure of information you have set in the computer memory. After reconnecting the battery, check that the memorized data has been retained. If it has been erased, input it into the computer once more.*

**THEFT PREVENTION LABELS  
(U.S.A.ONLY)**

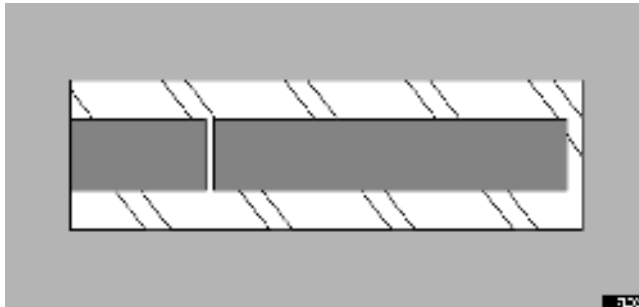

**Your new vehicle carries theft prevention labels which are approximately 56 mm (2.20 in.) by 16 mm (0.63 in.).**

The purpose of these labels is to reduce the incidence of vehicle thefts by facilitating the tracing and recovery of parts from stolen vehicles. The label is designed so that once it is applied to a surface, any attempt to remove it will result in destroying the integrity of the label. Transferring these labels intact from one part to another will be impossible.

***NOTICE***

***You should not attempt to remove the theft prevention labels as it may violate certain state or federal laws.***

## *SECTION 2*

---

### **AIR CONDITIONING AND AUDIO**

Automatic air conditioning controls .....	221
Audio system .....	237

### AUTOMATIC AIR CONDITIONING CONTROLS

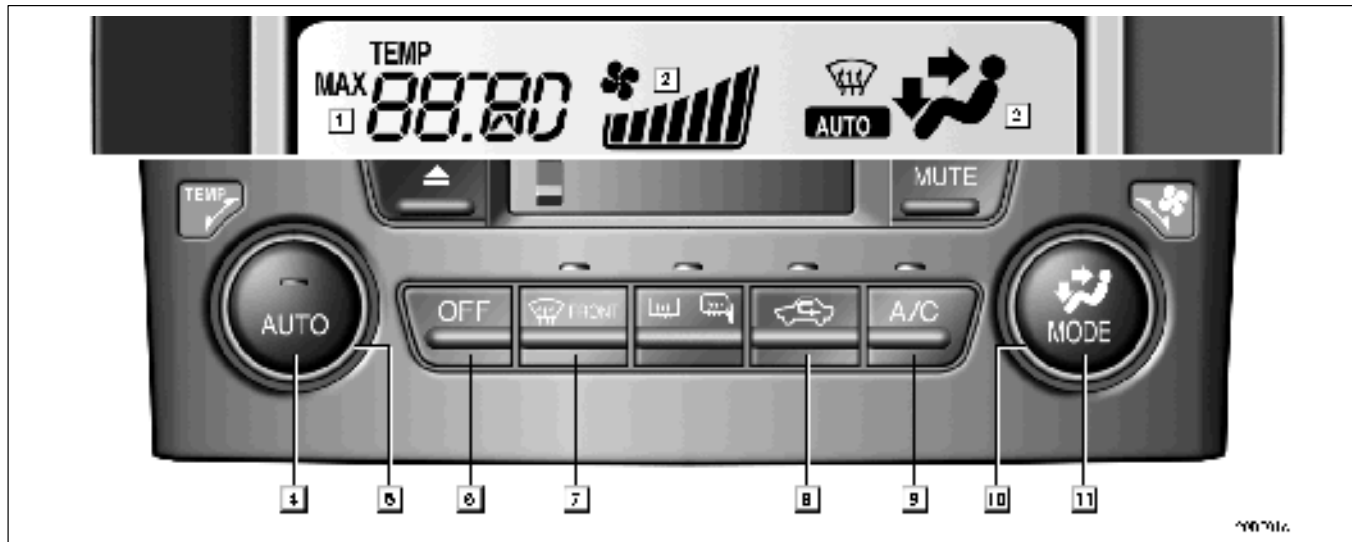

## AIR CONDITIONING AND AUDIO

---

► *You can adjust the brightness of the display. See page 243 for details.*

**The automatic air conditioning automatically maintains the set temperature.**

This air conditioning features automatic fan speed and air flow control which automatically selects the most suitable fan speed and air flow to control the temperature. The ignition key must be in the "ON" position.

### **NOTICE**

*To prevent the battery from being discharged, do not leave the air conditioning on longer than necessary when the engine is not running.*

- 1** *Temperature display (in degrees Fahrenheit or Centigrade)*
- 2** *Fan speed display*
- 3** *Air flow display*
- 4** *Automatic control button*
- 5** *Temperature control and outside temperature knob*
- 6** *OFF button*
- 7** *Front windshield button*
- 8** *Air intake control button*
- 9** *Air conditioning on-off button*
- 10** *Fan speed control button*
- 11** *Air flow control button*



## AIR CONDITIONING AND AUDIO

---

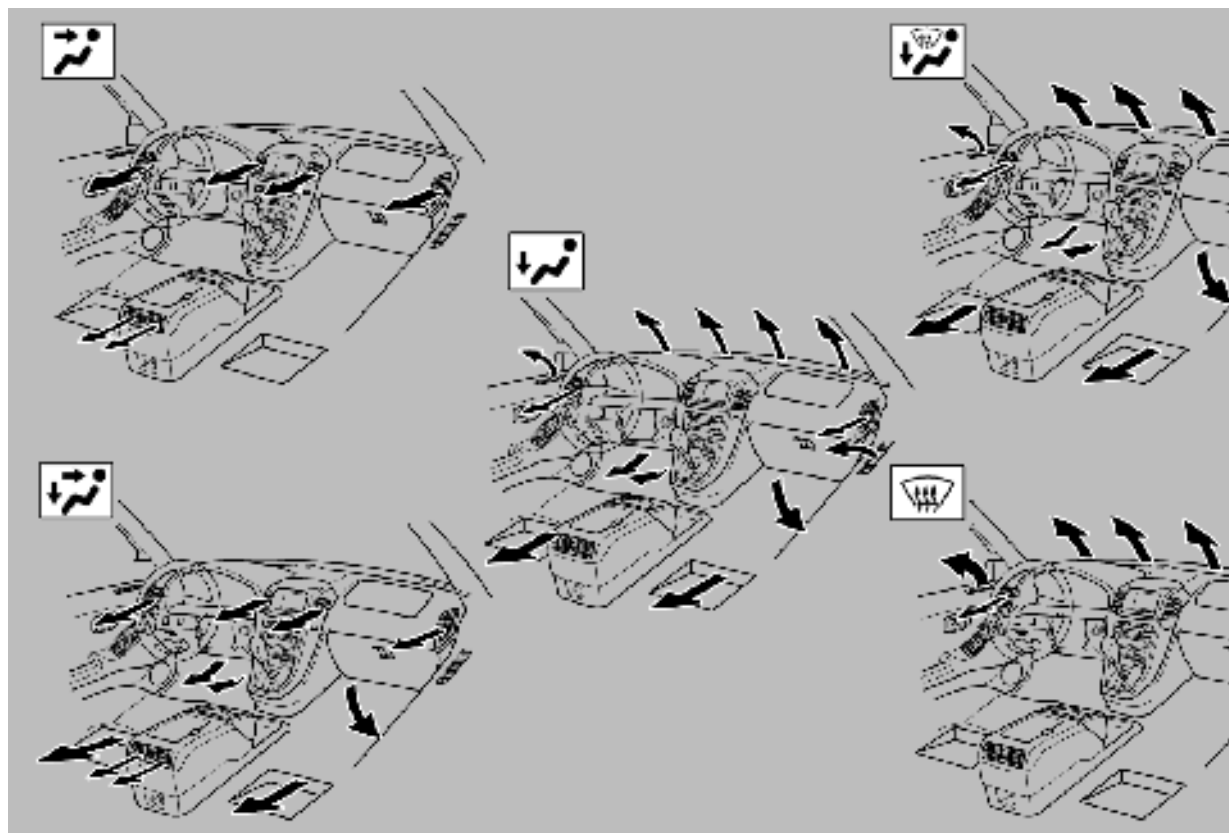

▶ *Air flow selection*

## AIR CONDITIONING AND AUDIO

---

### (a) Climate control

#### SETTING OPERATION – automatic control



#### 1. Push the "AUTO" button.

Air flow quantity, switching of the diffusers, on-off of the air conditioning and switching of the air intake between RECIRCULATED AIR and OUTSIDE AIR are automatically adjusted. The operation status is shown by each indicator.

When one of the manual control buttons is depressed while operating in automatic mode, the operation corresponding to the button depressed is set. Other conditions continue to be adjusted automatically.

Push the "OFF" button to turn the air conditioning system off.



**2. Turn the "TEMP" knob until the desired temperature is displayed.**

The "TEMP" knob is used to set the desired passenger compartment temperature. The temperature of air delivered to the passenger compartment will be controlled automatically according to the setting. The figures on the panel indicate degrees Fahrenheit or Centigrade.

**SETTING OPERATION – manual control**

**If manual air flow selection is desired –**

## AIR CONDITIONING AND AUDIO

---



The outlets from which air is delivered can be selected manually by pushing the button. The function of each mode is as follows:

- 1 **Panel** – Air flows mainly from the instrument panel vents.
- 2 **Bi-level** – Air flows from both the floor vents and the instrument panel vents.
- 3 **Floor** – Air flows mainly from the floor vents.
- 4 **Floor/Windshield** – Air flows mainly from the floor vents and windshield vents.

### **If quick heating or cooling is desired –**

Turn the "TEMP" knob until "MAX. HOT" or "MAX. COLD" appears on the display.

When the "MAX. COLD" is selected, the air intake is automatically set to "RECIRCULATED AIR" mode.

### **If manual fan speed control is desired –**

## AIR CONDITIONING AND AUDIO

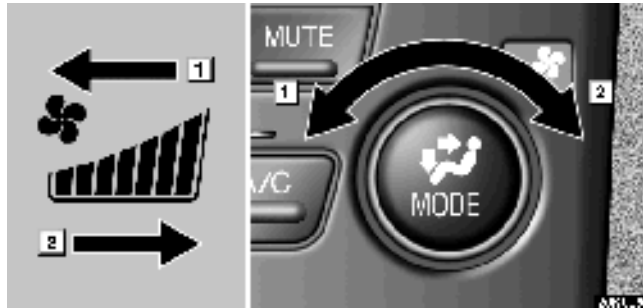

► **1** *Toward low fan speed* **2** *Toward high fan speed*

**If manual switching of air intake is desired –**

The fan speed can be set to your desired speed by turning the fan speed control button. The higher the fan speed is, the more air is delivered. Pushing the "OFF" button turns off the fan.

To remove exterior windshield frost, use the high speed setting.

## AIR CONDITIONING AND AUDIO

---

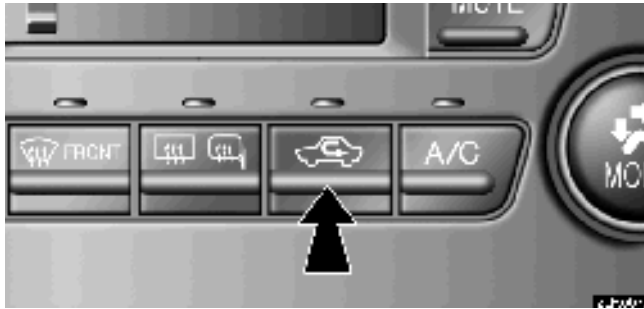

The air intake control button is used to switch the air intake between the OUTSIDE AIR mode and RECIRCULATED AIR mode. The indicator on the switch shows which mode is selected.

- **With the indicator on** – For RECIRCULATED AIR mode
- **With the indicator off** – For OUTSIDE AIR mode

For normal use, it is best to keep the setting to OUTSIDE AIR mode. If recirculated air is used during heating, the windows will fog up more easily.

If the engine coolant temperature becomes extremely high, the RECIRCULATED AIR mode is automatically selected. This is not a malfunction. When the engine coolant temperature is lowered, the previous mode resumes.

### **If manual on-off of the air conditioning is desired –**

Push the "A/C" button to turn the air conditioning on and push it again to turn the air conditioning off.

The air conditioning does not work if the outside temperature is lowered down to around 0°C (32°F).

If the system is used for ventilation, heating in dry weather or removing frost or exterior fog on the windshield, turn the air conditioning off once it is no longer required. This will improve fuel economy. The air conditioning can be used for year-round automatic temperature control including cooling and dehumidifying operation.

If the air conditioning compressor does not operate, the indicator of the "A/C" button will blink. If the indicator of the "A/C" button blinks even when the "A/C" button is pushed again, have the compressor checked by your nearest Lexus dealer.

**(b) Windshield defogging and defrosting**



**To remove interior fog on the windshield –**

Push the "FRONT WINDSHIELD" button.

**To remove frost or exterior fog on the windshield –**

1. Turn the "TEMP" knob at the maximum temperature.
2. Push the "FRONT WINDSHIELD" button.
3. Turn the "FAN SPEED CONTROL" button to obtain a maximum air flow.
4. Leave the air conditioning on-off button off.

When the "FRONT WINDSHIELD" button is pushed, the air conditioning is set to operate and the OUTSIDE AIR mode is set.

If you push the "FRONT WINDSHIELD" button once again while in the FRONT WINDSHIELD mode, the mode then returns to the last mode used.



## AIR CONDITIONING AND AUDIO

---



### CAUTION

Do not use the "FRONT WINDSHIELD" button during cooled air operation in extremely humid weather. The difference between the temperature of the outside air and that of the windshield could cause the outer surface of the windshield to fog up blocking your vision.

**(c) Air filter**

The air filter may clog after long use and reduce air flow. You can inspect the filter easily.

When you inspect and replace the air filter, be sure to turn off the fan.

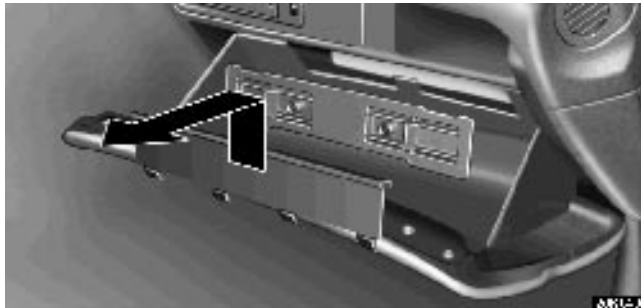

- 1. Open the glove box and remove the two covers.**

## AIR CONDITIONING AND AUDIO

---

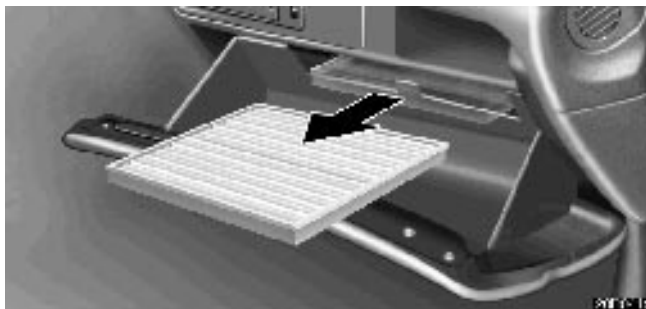

### **2. Take out the air filter.**

If it is dirty, it should be replaced. To maintain the air conditioning efficiency, replace the air filter according to the maintenance schedule. (For scheduled maintenance information, please refer to the separate "Owner's Manual Supplement/Maintenance Schedule".)

### ***NOTICE***

***Do not drive with the air filter removed, or the efficiency of air conditioning may be lost.***

**(d) Operating tips**

- Make sure the air inlet grilles in front of the windshield are not blocked by leaves or other obstructions.
- If air flow control is not satisfactory, check the dashboard vents. (See "Side vents" and "Rear vents".)
- To help cool down the interior after parking in the hot sun, drive for the first few minutes with the windows open. After the excess heat has blown away, close the windows.
- When driving on dusty roads, close all windows. If dust thrown up by the vehicle is still drawn into the vehicle after closing the windows, it is recommended that the air intake control button be left to the OUTSIDE AIR mode and the fan speed control button be pressed to anywhere except the "OFF" button.
- If following another vehicle on a dusty road, or driving in windy and dusty conditions, it is recommended that the air intake control button be temporarily pressed in to the RECIRCULATED AIR mode, which will close off the outside passage and prevent outside air and dust from entering the vehicle interior.

## AIR CONDITIONING AND AUDIO

---

### Side vents

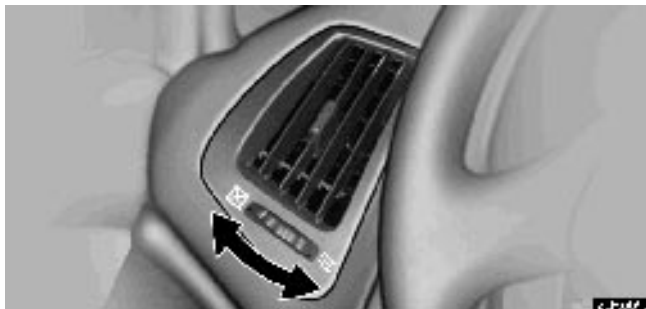

The side vents may be opened or closed as shown.

### Rear vents



The rear vents may be opened or closed as shown.

## AUDIO SYSTEM

Quick reference for your audio system

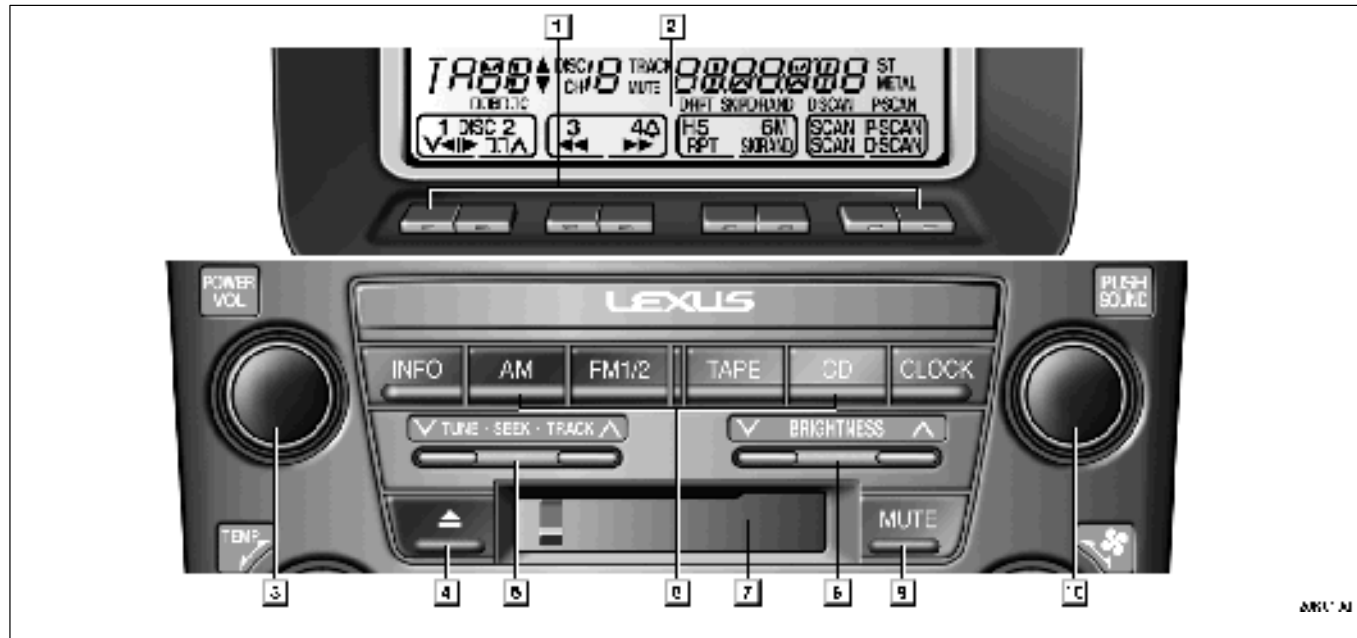

- The "CD" button works only when your Lexus is equipped with an automatic changer. Audio system made in Nakamichi has a "NAKAMICHI" logo on the panel.

## AIR CONDITIONING AND AUDIO

---

(See page 266 for details.)

### **1** Function buttons

**1 – 6:** Station selector buttons  
(See page 249 for details.)

**SCAN:** Scan tuning  
(See page 252 for details.)

**P-SCAN:** Preset scan tuning  
(See page 252 for details.)

### **2** Display of functions in TAPE mode

**◀▶:** Side change  
(See page 254 for details.)

**□□:** DOLBY NR  
(See page 254 for details.)

**◀◀:** Rewinding or Fast forwarding

**▶▶:** (See page 255 for details.)

**RPT:** Automatic repeat  
(See page 256 for details.)

**SKIP:** Automatic skip of blank portions of tape  
(See page 256 for details.)

**SCAN:** Scan selection  
(See page 256 for details.)

### **2** Display of functions in CD mode

**∨ Λ:** Disc selection  
(See page 262 for details.)

**◀◀:** Reversing or Fast forwarding

**▶▶:** (See page 266 for details.)

**RPT:** Automatic repeat

**RAND:** Random access  
(See page 267 for details.)

**SCAN:** Scan selection  
(See page 264 for details.)

**D-SCAN:** Disc scan selection  
(See page 265 for details.)

**3 Turning the system on and adjusting volume**  
(See page 240 for details.)

**4 Stopping and ejecting a cassette tape**  
(See page 252 for details.)

**5 Radio mode:** Frequency tuning  
(See page 248 or 250 for details.)

**TAPE mode:** Direct access to a desired program  
(See page 257 for details.)

**CD mode:** Direct access to a desired program  
(See page 265 for details.)

**6 Mode selectors**  
(See page 242 for details.)

**7 Cassette tape slot**  
(See page 252 for details.)

**8 Brightness button:** Adjusting brightness of display  
(See page 243 for details.)

**9 Mute button**  
(See page 241 for details.)

**10 Audio control knob**  
(See page 245 for details.)



## AIR CONDITIONING AND AUDIO

---

### Using your audio system: some basics

This section describes some of the basic features of the Lexus audio system. Some information may not pertain to your system.

Your audio system works when the ignition key is in the "ACC" or "ON" position.

#### **NOTICE**

*To prevent the battery from being discharged, do not leave the car audio on longer than necessary when the engine is not running.*

#### (a) Turning the system on and off



**Push this knob to turn the audio system on and off. Turn this knob to adjust the volume.**

The system turns on in the last mode used.



**Push the "MUTE" button to decrease the volume momentarily.**

To return to its original volume, push the same button again.

When the audio system is turned on, the mute is always off regardless of the previous mode.

## AIR CONDITIONING AND AUDIO

---



**Push "AM", "FM1/2", "TAPE" or "CD" to turn on that mode. The selected mode turns on directly.**

Push these buttons if you want to switch from one mode to another.

If the tape or disc is not set, the cassette player or compact disc player does not turn on.

You can turn off the cassette player by ejecting the cassette tape. If the audio system was previously off, then the entire audio system will be turned off when you eject the cassette tape. If another function was previously playing, it will come on again.



The applicable functions are shown in the lowest part of the display. Push the switch just below to turn on each function.

(b) Brightness buttons



## AIR CONDITIONING AND AUDIO

---

### ► 1 *Darken* 2 *Brighten*

The buttons adjust the brightness of the display. Each time you push the button on the "∧" side, the display becomes bright. Each time you push the button on the "∨" side, the display becomes dark.

### (c) **Tone and balance**

How good an audio program sounds to you is largely determined by the mix of the treble, mid-range, and bass levels. In fact, different kinds of music and vocal programs usually sound better with different mixes of treble, mid-range, and bass.

A good balance of the left and right stereo channels and of the front and rear sound levels is also important.

Keep in mind that if you are listening to a stereo recording or broadcast, changing the right/left balance will increase the volume of one group of sounds while decreasing the volume of another.



## AIR CONDITIONING AND AUDIO

---

**Each time you push the "AUDIO CONTROL" knob, the display changes as in the following. To adjust the tone and balance, turn the knob.**

**BAS:** Adjusts low-pitched tones.

**MIId:** Adjusts mid-pitched tones.

**TRE:** Adjusts high-pitched tones.

**FAd:** Adjusts the sound balance between the front and rear speakers.

**BAL:** Adjusts the sound balance between the right and left speakers.

### **(d) Your radio antenna**

The antenna automatically extends when the radio and ignition are turned on and retracts when either is turned off.

## AIR CONDITIONING AND AUDIO

---



### CAUTION

Before extending the antenna, confirm that no one is close enough to get injured.

### NOTICE

- *To prevent damage to the antenna, make sure it is retracted before driving your vehicle through an automatic car wash.*
- *When cleaning the inside of the left quarter window, be careful not to scratch or damage the wire antenna.*
- *Putting a window tint (especially, conductive or metallic type) on the left quarter window may affect the reception of radio or mobile telephone. For the installation of the window tint, consult with your Lexus dealer.*

### (e) Your cassette player

When you insert a cassette, the exposed tape should be to the right.

### NOTICE

*Do not oil any part of the cassette player, and do not insert anything except a cassette tape into the slot.*

**(f) Your automatic changer**



If your Lexus is equipped with an automatic changer, it can play selected discs or continuously play all the discs set in the magazine.

***NOTICE***

***Never try to disassemble or oil any part of the compact disc player. Do not insert anything except a compact disc into the magazine.***

The player is intended for use with 12 cm (4.7 in.) discs only.



## AIR CONDITIONING AND AUDIO

---

### Radio operation

#### (a) Listening to the radio



Push these buttons to choose either an AM or FM station.

"AM", "FM1" or "FM2" appears on the display.

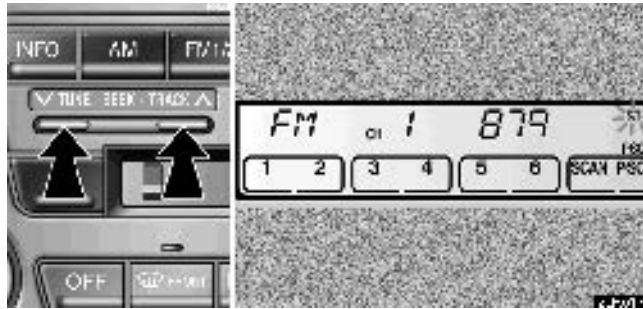

**Push this button on the upper side to step up the station band or on the lower side to step down.**

**(b) Presetting a station**

Your radio automatically changes to stereo reception when a stereo broadcast is received. "ST" appears on the display. If the signal becomes weak, the radio reduces the amount of channel separation to prevent the weak signal from creating noise. If the signal becomes extremely weak, the radio switches from stereo to mono reception. In this case, "ST" disappears from the display.

## AIR CONDITIONING AND AUDIO

---



1. Tune in the desired station.
2. Push one of the station selector buttons ( 1–6 ) and hold it until a beep is heard. This sets the station to the button and the button number ( 1–6 ) appears on the display.

Each button can store one AM station and two FM stations. To change the preset station to a different one, follow the same procedure.

The preset station memory is cancelled when the power source is interrupted by battery disconnection or a blown fuse.

### (c) Selecting a station

Your Lexus has an electronic tuning radio (ETR). Tune in the desired station using one of the following methods.



**Preset tuning:** Push the button ( 1–6 ) for the station you want briefly. The button number ( 1–6 ) and station frequency appear on the display.

**Manual tuning:** Push the "TUNE SEEK" button briefly. Each time you push the button, the radio will step up or down to another frequency.

**Seek tuning:** Push the "TUNE SEEK" button and hold it until you hear a beep. The radio will begin seeking up or down for a station of the nearest frequency and will stop on reception. Each time you push the button, the stations will be searched out one after another.

## AIR CONDITIONING AND AUDIO

---

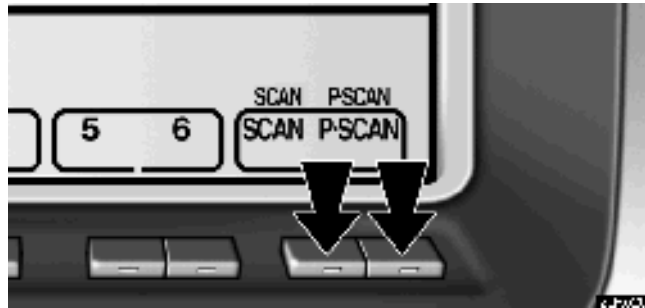

**To scan all the frequencies:** Push the "SCAN" button. "SCAN" appears on the display. The radio will find the next station up the band, stay there for a few seconds, and then scan again. To select a station, push the "SCAN" button a second time.

**To scan the preset stations:** Push the "P-SCAN" button. "P-SCAN" appears on the display. The radio will tune in the next preset station up the band, stay there for a few seconds, and then move to the next preset station. To select a station, push the "P-SCAN" button a second time.

### Cassette tape player operation

#### (a) Playing a cassette tape



**When you insert a cassette tape, the exposed tape should be to the right.**

The player will automatically start when you insert a cassette tape. At this time, "TAPE" appears on the display.

If a metal or chrome equivalent cassette tape is put in the cassette player, the player will automatically adapt to it and "METAL" appears on the display.

To stop or eject the cassette tape, push the "EJECT" button.

**Auto-reverse feature:** After the cassette player reaches the end of a tape, it automatically reverses and begins to play the other side, regardless of whether the cassette was playing or fast forwarding.

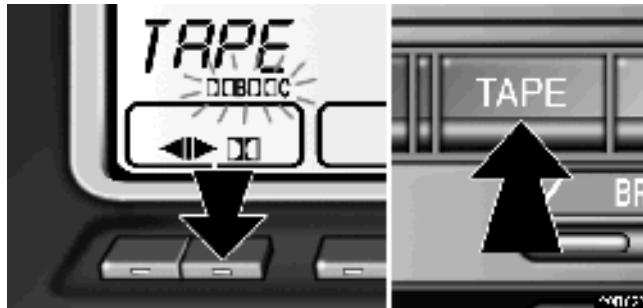

## AIR CONDITIONING AND AUDIO

---

**If a cassette is already in the slot, push the "TAPE" button.**

**Dolby Noise Reduction\* feature:** If you are listening to a tape that was recorded with Dolby\* B or C Noise Reduction, push the button by the double-D symbol until the appropriate symbol appears on the display.

The Dolby B NR mode reduces tape noise by about 10 dB. The Dolby C NR mode reduces tape noise by another 10 dB or about 20 dB total. For best sound reproduction, select the same NR mode that was used to record the tape.

To play a tape recorded without Dolby NR, push the button until the symbol disappears from the display.

\* Dolby noise reduction manufactured under license from Dolby Laboratories Licensing Corporation. "DOLBY" and the double-D symbol  are trademarks of Dolby Laboratories Licensing Corporation.

**(b) Manual program selection**

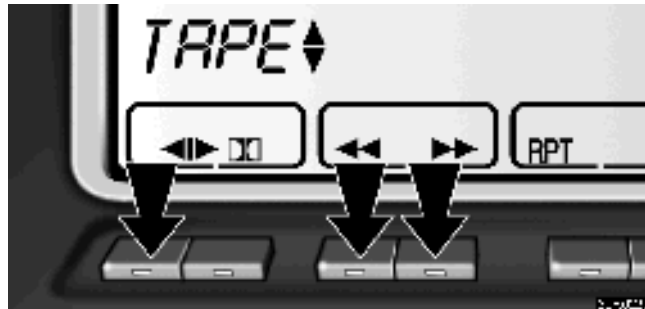

**"Program" button:** Push the "◀|▶" button to select the other side of a cassette tape. The display indicates which side is currently selected (▲ indicates top side, ▼ indicates bottom side).

**"Rewind" button:** Push the "◀◀" button to rewind a tape. "REW" appears on the display.

To stop rewinding, push the same button or "TAPE" button.

**"Fast forward" button:** Push the "▶▶" button to fast forward a cassette tape. "FF" appears on the display.

To stop fast forwarding, push the same button or "TAPE" button.

(c) Automatic program selection

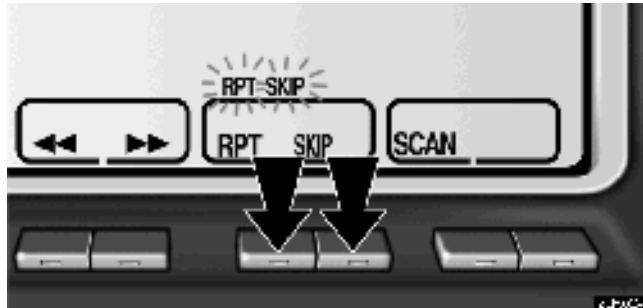



## AIR CONDITIONING AND AUDIO

---

**”RPT” button:** The repeat feature automatically replays the current program.

Push the ”RPT” button while the program is playing. When the program ends, it will automatically be rewound and replayed. Push the button again to turn off the repeat feature.

There must be at least 4 seconds of blank space between programs for the repeat feature to work correctly.

**”SKIP” button:** The skip feature allows you to fast forward past long stretches of blank tape. This is especially useful at the end of cassettes.

Push the ”SKIP” button. The player will automatically skip any blank portions of 15 seconds or more and play the next program. To cancel it, push the button once again.

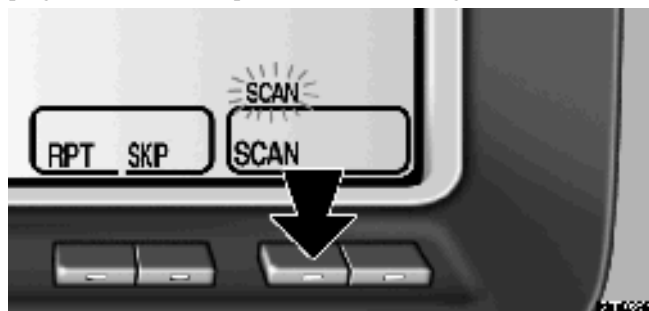

**”SCAN” button:** Push the ”SCAN” button. ”SCAN” appears on the display. The player will fast forward to the next program, play it for 12 seconds, and then scan again. To select a program, push the ”SCAN” button a second time.

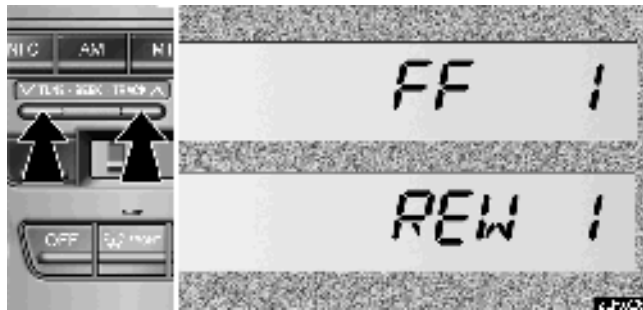

**"Automatic program selection" button:** The automatic program selection feature allows you to program your cassette player to skip forward or backward to locate the song you want to hear. You can skip up to nine programs at a time.

Push this button on the right side to skip forward. "FF" and the number will appear on the display. Push the button until the number you want to skip appears on the display. After that, the player will automatically skip forward.

When the end of the tape is reached, the player automatically reverses sides and resumes normal play.

Push this button on the left side to skip backward. Push the button until "REW" and the number you want to skip appear on the display.

- If you set "REW 1", the player will rewind to the beginning of the current program.

- When counting the number of programs you want to rewind, remember to count the current program as well. For example, if you want to rewind to a song that is two before the song you are listening to, push this button until "REW 3" appears on the display.

When the beginning of the tape is reached, the player automatically resumes normal play.

There must be at least 3 seconds of blank space between programs for this feature to work correctly.

**"RPT", "SKIP" or "Automatic program selection" features:** These features may not work well with some spoken word, live or classical recordings.

## AIR CONDITIONING AND AUDIO

---

### Compact disc player operation

The compact disc player is an optional accessory that your vehicle is pre-wired to accept. Although your audio system has a "CD" button, your vehicle may or may not be equipped with a CD player. Please contact your dealer for additional details if you would like to have the optional CD player installed.

#### (a) Inserting compact discs



1. Pull the lever and open the glove box door.



**2. Push this button to eject the magazine.**



**3. Pull out the tray while pushing the lock release button.**

## AIR CONDITIONING AND AUDIO

---

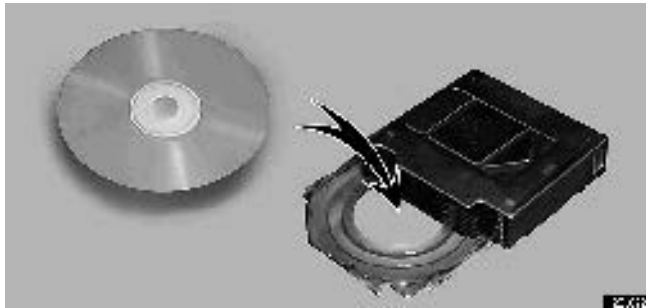

**4. Put a disc on the tray with its label face down and push the tray back into the magazine.**

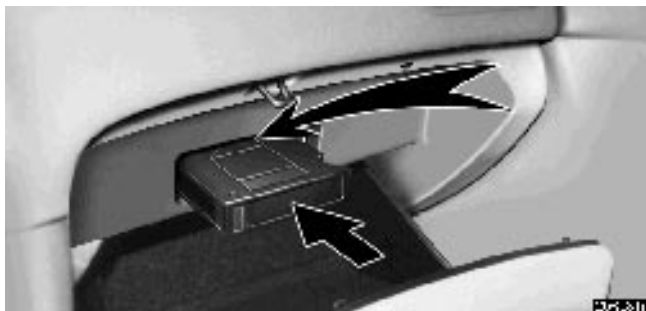

**5. Insert the magazine into the player as indicated by the arrow head on the magazine and close the glove box door.**

When the magazine is set completely, the system will be in a "Load" cycle for approximately 20 seconds while the system searches for discs in the magazine. Upon completion of this cycle, the CD unit will be ready to play. If the "CD" button is pushed during the "Load" cycle, "LOAD" appears on the display until the system has completed the load cycle, after which the system will begin normal play.



### CAUTION

**To reduce the chance of injury in case of an accident or a sudden stop, always keep the glove box door closed while driving.**

## AIR CONDITIONING AND AUDIO

---

### (b) Playing a compact disc



**Push the "CD" button if the magazine is already loaded in the player.**

**(c) Selecting a desired disc**

"CD" appears on the display.

The discs set in the magazine are played continuously, starting with disc number 1. The disc number of the disc currently being played, the track number and the time from the beginning of the program appear on the display.

When play of one disc ends, the first track of the following disc starts. When play of the final disc ends, play of the first disc starts again.

The player will skip any empty disc trays.



**Push the "DISC" button to select the disc number.**

Push the button several times until the desired disc number appears on the display. When you release the button, the player will start playing the selected disc from the first track.

**(d) Searching for a desired track**

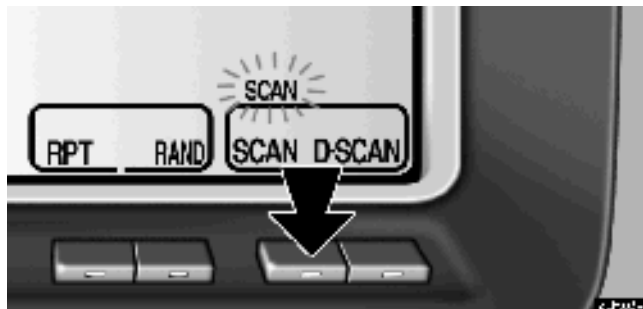



## **AIR CONDITIONING AND AUDIO**

---

### **Push the "SCAN" button.**

"SCAN" will appear on the display. The compact disc player will play the next track for 10 seconds, then scan again. To select a track, push the "SCAN" button a second time. If the player reaches the end of the disc, it will continue scanning at track 1.

After all the tracks are scanned in one pass, normal play resumes.

### **(e) Searching for a desired disc**

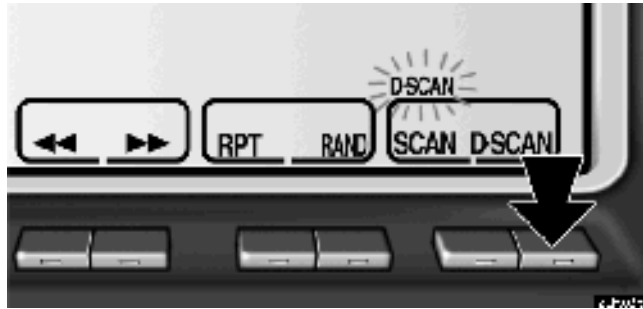

**Push the "D-SCAN" button.**

**(f) Selecting a desired track**

With "D-SCAN" on the display, the program at the beginning of each disc will be played for 10 seconds. To continue listening to the program of your choice, push the "D-SCAN" button a second time.

After all the discs in the magazine are scanned in one pass, the scan function is cancelled.

## AIR CONDITIONING AND AUDIO

---

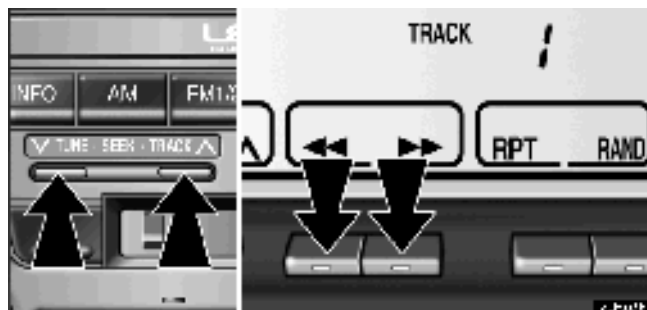

**"TRACK" button:** Use for direct access to a desired track.

Push either side of the "TRACK" button several times until the desired track number appears on the display. As you release the button, the player will start playing the selected track from the beginning.

**"Fast forward" button.**

Push the "▶▶" button and hold it to fast forward the disc. When you release the button, the compact disc player will resume playing from that position.

**"Reverse" button.**

Push the "◀◀" button and hold it to reverse the disc. When you release the button, the compact disc player will resume playing.

(g) Repeating a track or a disc

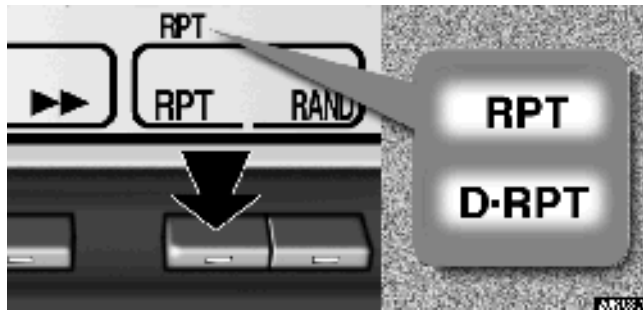

**"RPT" button:** There are 2 repeat features — you can either replay a disc track or a whole compact disc.

**Repeating a track:** Push the "RPT" button briefly while the track is playing. "RPT" will appear on the display. When the track ends, it will automatically be replayed. This process will be continued until you push the button again to turn off the repeat feature.

**Repeating a disc:** Push the "RPT" button until you hear a beep. "D-RPT" will appear on the display. The player will repeat all the tracks on the disc you are listening to. When the disc ends, the player will automatically go back to the top track of the disc and replay. This process will be continued until you push the button again to turn off the repeat feature.

(h) Random playing

## AIR CONDITIONING AND AUDIO

---

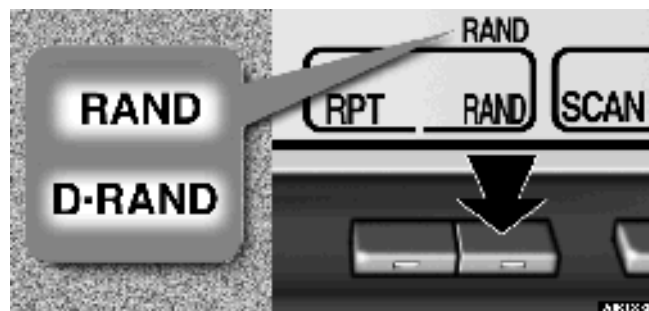

**"RAND" button:** There are 2 random features — you can either listen to the tracks on all the compact discs in the magazine in random order, or only listen to the tracks on a specific compact disc in random order.

**Random playing for the tracks on a disc:** Push the "RAND" button briefly. "RAND" will appear on the display and play the disc you are listening to in random order.

**Random playing for all the tracks in the magazine:** Push the "RAND" button until you hear a beep. "D-RAND" will appear on the display and the player will perform all the tracks on all the discs in the magazine in random order. To turn off the random feature, push "RAND" a second time.

When a track is skipped or the system is inoperative, push the button to reset.

### (i) If the player malfunctions

If "WAIT" appears on the display, audio signals of the disc cannot be read or the system has trouble. Push the "CD" button once again.

If the player does not operate, check that the disc surface is not soiled or damaged. If the disc is O.K., the following causes are possible.

- Condensation may have occurred on the internal mechanism of the automatic changer. Open the cover to let the air circulate.
- The temperature of the player's internal mechanism is raised because of high external temperature. Remove the magazine from the player to cool it.

If the player still does not operate, take it to your Lexus dealer.

**Car audio system operating hints**

**NOTICE**

*To ensure the correct audio system operation:*

- *Be careful not to spill beverages over the audio system.*
- *Do not put anything other than a cassette tape or CD magazine into the cassette tape slot or CD changer.*
- *The use of cellular phone inside or near the vehicle may cause a noise from the speakers of the audio system which you are listening to. However, this does not indicate a malfunction.*

**Radio reception**

Usually, the problem with radio reception does not mean there is a problem with your radio – it is just the normal result of conditions outside the vehicle.

For example, nearby buildings and terrain can interfere with FM reception. Power lines or telephone wires can interfere with AM signals. And of course, radio signals have a limited range, and the farther you are from a station, the weaker its signal will be. In addition, reception conditions change constantly as your vehicle moves.

Here are some common reception problems that probably do not indicate a problem with your radio:

**FM**

**Fading and drifting stations** – Generally, the effective range of FM is about 40 km (25 miles). Once outside this range, you may notice fading and drifting, which increase with the distance from the radio transmitter. They are often accompanied by distortion.

**Multi-path** – FM signals are reflective, making it possible for two signals to reach your antenna at the same time. If this happens, the signals will cancel each other out, causing a momentary flutter or loss of reception.

**Static and fluttering** – These occur when signals are blocked by buildings, trees, or other large objects. Increasing the bass level may reduce static and fluttering.

## AIR CONDITIONING AND AUDIO

---

**Station swapping** – If the FM signal you are listening to is interrupted or weakened, and there is another strong station nearby on the FM band, your radio may tune in the second station until the original signal can be picked up again.

### AM

**Fading** – AM broadcasts are reflected by the upper atmosphere – especially at night. These reflected signals can interfere with those received directly from the radio station, causing the radio station to sound alternately strong and weak.

**Station interference** – When a reflected signal and a signal received directly from a radio station are very nearly the same frequency, they can interfere with each other, making it difficult to hear the broadcast.

**Static** – AM is easily affected by external sources of electrical noise, such as high tension power lines, lightning, or electrical motors. This results in static.

### Caring for your cassette player and tapes

For high performance from your cassette player and tapes:

Clean the tape head and other parts regularly.

- A dirty tape head or tape path can decrease sound quality and tangle your cassette tapes. The easiest way to clean them is by using a cleaning tape. (A wet type is recommended.)

Use high-quality cassettes:

- Low-quality cassette tapes can cause many problems, including poor sound, inconsistent playing speed, and constant auto-reversing. They can also get stuck or tangled in the cassette player.
- Do not use a cassette if it has been damaged or tangled or if its label is peeling off.
- Do not leave a cassette in the player if you are not listening to it, especially if it is hot outside.
- Store cassettes in their cases and out of direct sunlight.
- Avoid using cassettes with a total playing time longer than 100 minutes (50 minutes per side). The tape used in these cassettes is thin and could get stuck or tangled in the cassette player.

**Caring for your compact disc player and discs**



- Use only compact discs labeled as shown. The player is intended for use with 12 cm (4.7 in.) discs only.
- Extremely high temperature can keep your compact disc player from working. On hot days, use air conditioning to cool the vehicle interior before you listen to a disc.
- Bumpy roads or other vibrations may make your compact disc player skip.
- If moisture gets into your compact disc player, you may not hear any sound even though your compact disc player appears to be working. Remove the magazine from the player and wait until it dries.



## AIR CONDITIONING AND AUDIO

---

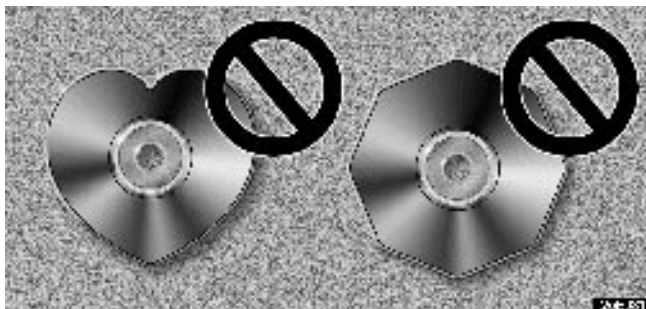

Your automatic changer cannot play special shaped compact discs as shown. Do not use them as the changer could be damaged.

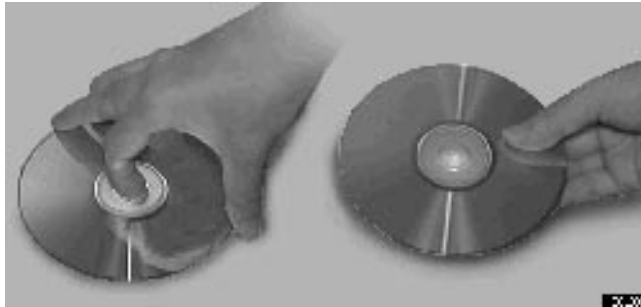

▶ *Correct*

▶ *Wrong*

- Handle compact discs carefully, especially when you set them into the magazine. Hold them on the edge and do not bend them. Avoid getting fingerprints on them, particularly on the shiny side.
- Dirt, scrapes, warping, pin holes, or other disc damage could cause the player to skip or to repeat a section of a track. (To see a pin hole, hold the disc up to the light.)

## AIR CONDITIONING AND AUDIO

---



**To clean a compact disc:** Wipe it with a soft, lint-free cloth that has been dampened with water. Wipe in a straight line from the center to the edge of the disc (not in a circle). Do not use a conventional record cleaner or anti-static device.

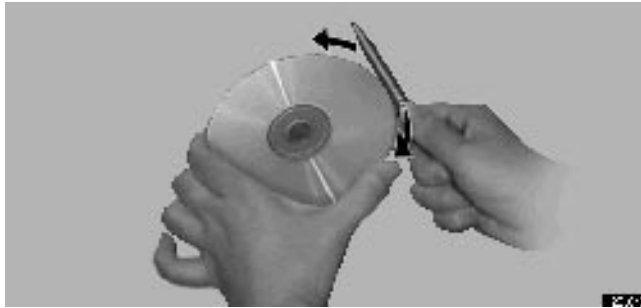

**A new disc may have rough edges on its inner and outer perimeter. Remove the rough edges by pressing the side of a ball-point pen or pencil against the inner and outer edges of the disc as shown.**

If you continue to play a disc with rough edges, flakes will fall on to the signal side of the disc and cause sound skipping or other problems.



**CAUTION**

**Compact disc players use invisible laser beams which could cause hazardous radiation exposure if directed outside the unit. Be sure to operate the player correctly as instructed.**

## *SECTION 3 - 1*

---

### **STARTING AND DRIVING**

#### **Starting and driving**

Three-way catalytic converter Warm up three-way catalytic converter .....	276
Engine exhaust caution .....	279
Before starting the engine .....	280
Ignition switch with steering lock .....	281
Parking brake .....	283
How to start the engine .....	285
Automatic transmission .....	286
Cruise control .....	299
Traction control system .....	303
Brake system .....	306
Brake pad wear limit indicators .....	311
Types of tires .....	312

### **THREE-WAY CATALYTIC CONVERTER**

### **WARM UP THREE-WAY CATALYTIC CONVERTER**

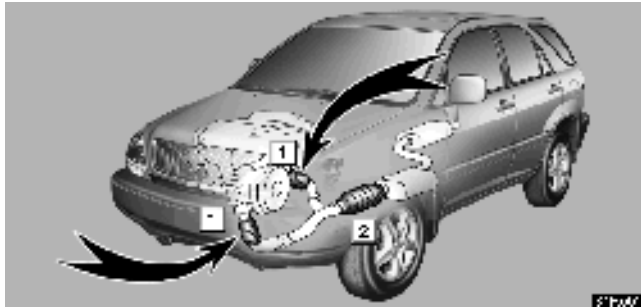

- ▶ **1** *Warm up three-way catalytic converter*
- ▶ **2** *Three-way catalytic converter*

**The three-way catalytic converter/warm up three-way catalytic converter is an emission control device installed in the exhaust system.**

It looks somewhat like a muffler, but its purpose is to reduce pollutants in the exhaust gas.

## STARTING AND DRIVING

---



### CAUTION

- Keep people and combustible materials away from the exhaust pipe while the engine is running. The exhaust gas is very hot.
- Do not drive, idle or park your vehicle over anything that might burn easily such as grass, leaves, paper or rags.

### NOTICE

*A large amount of unburned gases flowing into the three-way catalytic converter/warm up three-way catalytic converter may cause it to overheat and create a fire hazard. To prevent this and other damage, observe the following precautions:*

- *Use only unleaded gasoline.*
- *Do not drive with an extremely low fuel level; running out of fuel could cause the engine to misfire, creating an excessive load on the three-way catalytic converter/warm up three-way catalytic converter.*
- *Do not allow the engine to run at idle speed for more than 20 minutes.*
- *Avoid racing the engine.*
- *Do not push-start or pull-start your vehicle.*
- *Do not turn off the ignition while the vehicle is moving.*

- *Keep your engine in good running order. Malfunctions in the engine electrical system, electronic ignition system/distributor ignition system or fuel system could cause an extremely high three-way catalytic converter/warm up three-way catalytic converter temperature.*
- *If the engine becomes difficult to start or stalls frequently, take your vehicle in for a check-up as soon as possible. Remember, your Lexus dealer knows your vehicle and its three-way catalytic converter/warm up three-way catalytic converter system best.*
- *To ensure that the three-way catalytic converter/warm up three-way catalytic converter and the entire emission control system operate properly, your vehicle must receive the periodic inspections required by the Lexus Maintenance Schedule. For scheduled maintenance information, refer to the separate "Owner's Manual Supplement/ Maintenance Schedule".*

## ENGINE EXHAUST CAUTION



### CAUTION

- Avoid inhaling the engine exhaust. It contains carbon monoxide, which is a colorless and odorless gas. It can cause unconsciousness or even death.
- Make sure the exhaust system has no holes or loose connections. The system should be checked from time to time. If you hit something, or notice a change in the sound of the exhaust, have the system checked immediately.
- Do not run the engine in a garage or enclosed area except for the time needed to drive the vehicle in or out. The exhaust gases cannot escape, making this a particularly dangerous situation.
- Do not remain for a long time in a parked vehicle with the engine running. If it is unavoidable, however, do so only in an unconfined area and adjust the heating or cooling system to force outside air into the vehicle.
- Keep the back door closed while driving. An open or unsealed back door may cause exhaust gases to be drawn into the vehicle.
- To allow proper operation of your vehicle's ventilation system, keep the inlet grilles in front of the windshield clear of snow, leaves, or other obstructions.



## STARTING AND DRIVING

---

- **If you smell exhaust fumes in the vehicle, drive with the windows open and the back door closed. Have the cause immediately located and corrected.**

### **BEFORE STARTING THE ENGINE**

1. Check the area around the vehicle before entering it.
2. Adjust seat position, seatback angle, head restraint height and steering wheel angle.
3. Adjust inside and outside rear view mirrors.
4. Lock all doors.
5. Fasten seat belts.

Remember to check that the service reminder indicators function when turning the key to "ON", and check the fuel gauge to see that you have sufficient fuel.

## IGNITION SWITCH WITH STEERING LOCK

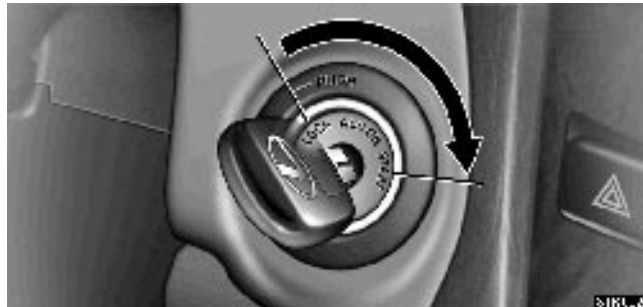

## STARTING AND DRIVING

---

**”START”** – Starter motor on. The key will return to the **”ON”** position when released.

For starting tips, see page 285.

**”ON”** – Engine on and all accessories on.

This is the normal driving position.

### **NOTICE**

*Do not leave the key in the ”ON” position if the engine is not running. The battery will discharge and the electronic ignition system/distributor ignition system could be damaged.*

**”ACC”** – Accessories such as the radio operate, but the engine is off.



If you leave the key in the **”ACC”** or **”LOCK”** position and open the driver’s door, a buzzer will remind you to remove the key.\*

*NOTE: \*The volume or interval of beep sound can be changed. Ask your Lexus dealer for details.*

**”LOCK” – Engine is off and the steering wheel is locked.  
The ignition key can be removed only at this position.**

You must push in the key to turn it from ”ACC” to the ”LOCK” position. The selector lever must be put in the ”P” position before turning the key to the ”LOCK” position.

Once you remove the key, the engine immobiliser system is automatically set. See ”Engine immobiliser system” on page 12.

When starting the engine, the key may seem stuck at the ”LOCK” position. To free it, first be sure the key is pushed all the way in, and then rock the steering wheel slightly while turning the key gently.

If, in an emergency, you must turn the engine off while the vehicle is moving, turn the key only to ”ACC”.

## PARKING BRAKE

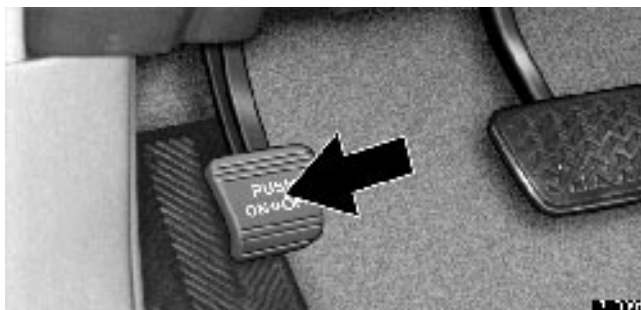

## STARTING AND DRIVING

---

**To set:** Hold the regular brake pedal down with your right foot. Push down the parking brake pedal with your left foot.

**To release:** Hold the regular brake pedal down with your right foot and push the parking brake pedal with your left foot. When you lift your left foot, the parking brake pedal will follow it to the released position.

Before leaving your vehicle, firmly apply the parking brake.



### CAUTION

Before driving, make sure the parking brake is fully released and that the parking brake reminder light is off.

## HOW TO START THE ENGINE

### Before cranking

1. Apply the parking brake firmly.
2. Turn off unnecessary lights and accessories.
3. Put the selector lever in "P". If you need to restart the engine while the vehicle is moving, put the selector lever in "N". A starter safety device will prevent the starter from operating if the selector lever is in any drive position.
4. Depress the brake pedal and hold it to the floor until you are ready to drive off.

### Starting the engine

Before starting the engine, be sure to follow the instructions in "Before cranking".

#### Normal starting procedure

The multiport fuel injection system/sequential multiport fuel injection system in your engine automatically controls the proper air–fuel mixture for starting. You can start a cold or hot engine as follows:

1. With your foot off the accelerator pedal, crank the engine by turning the key to "START". Release it when the engine starts.
2. After the engine runs for about 10 seconds, you are ready to drive.

If the weather is below freezing, let the engine warm up for a few minutes before driving. Do not leave the vehicle while the engine is warming up.

#### If the engine stalls ...

Simply restart it , using the correct procedure given in normal starting.

#### If the engine will not start

See "If your vehicle will not start" on page 338.

### **NOTICE**

- *Do not crank for more than 30 seconds at a time. This may overheat the starter and wiring systems.*
- *Do not race a cold engine.*
- *If the engine becomes difficult to start or stalls frequently, have the engine checked immediately.*

## STARTING AND DRIVING

---

### AUTOMATIC TRANSMISSION

Your automatic transmission has a shift lock system to minimize the possibility of incorrect operation. This means you can only shift out of "P" position when the brake pedal is depressed (with the ignition switch in "ON" position and the lock release button pressed in). (★)

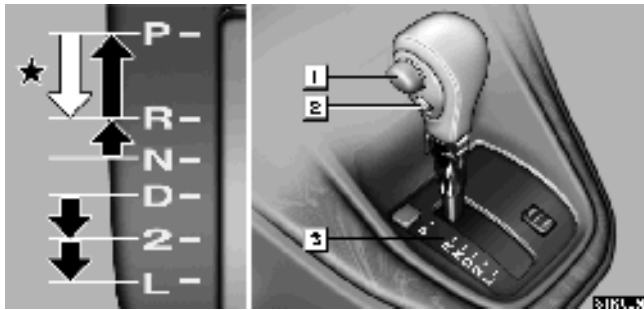

#### 1 Lock release button

↓ With the brake pedal depressed, shift while holding the lock release button in. (The ignition switch must be in the "ON" position)

↓↑ Shift while holding the lock release button in.

**2 Overdrive switch**

For selecting either a three-speed or four-speed transmission.

When the cruise control is being used, even if you downshift the transmission by turning off the overdrive switch, engine braking will not be applied because the cruise control is not cancelled. For the operation to decrease the vehicle speed, see page 302.

**3 Shift position indicator**

The shift position is also displayed on the instrument cluster.

**P:** Parking, engine starting and key removal position

**R:** Reverse position

**N:** Neutral position

**D:** Normal driving position (Shifting into overdrive possible)

**2:** Position for engine braking

**L:** Position for stronger engine braking than that in "2" position

**Correct use of the automatic transmission is explained in the following parts.**

- (a) Normal driving
- (b) Using engine braking
- (c) Using the "2" and "L" positions
- (d) Backing up
- (e) Parking
- (f) Good driving practice
- (g) Rocking your vehicle if stuck
- (h) If you cannot shift the selector lever out of "P" position
- (i) If the "O/D OFF" indicator light flashes
- (j) Driving in "Snow" mode



## STARTING AND DRIVING

---

### (a) Normal driving

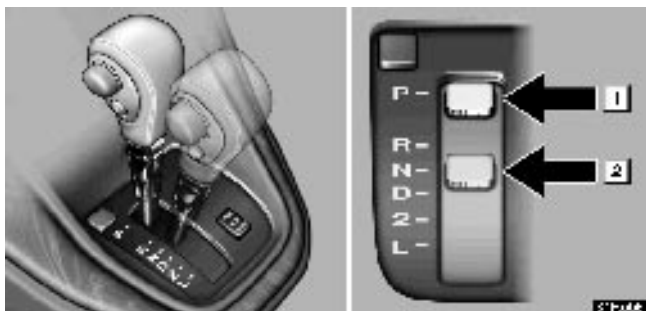

► **1** "P" (Park) position   **2** "N" (Neutral) position

**1. Start the engine as instructed in "How to start the engine" on page 285.**

The transmission must be in "P" or "N". The engine will not start in "R", "2", "L" or "D" position even if the ignition key is turned to "START".

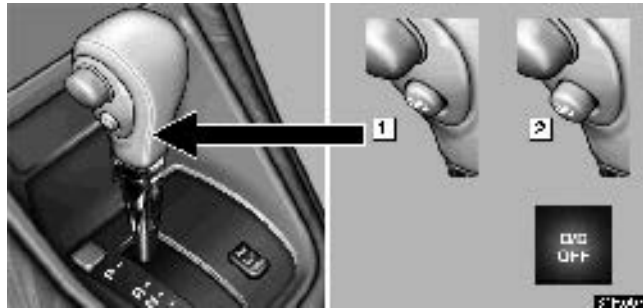

▶ **1** *On* **2** *Off*

**2. Set the overdrive switch to the ON position.**

Always set the overdrive switch to the ON position to improve fuel economy and quiet driving. (See "(b) Using engine braking" and "(f) Good driving practice" for exceptions.)

## STARTING AND DRIVING

---

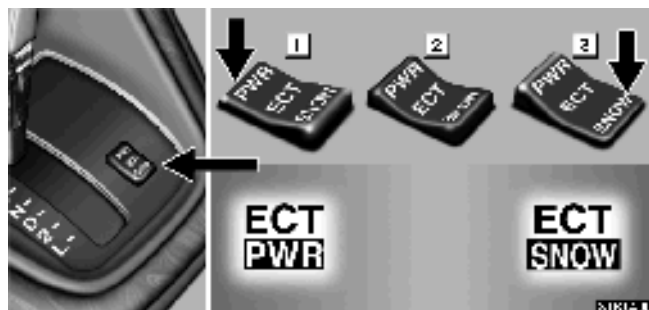

- **1** Power position   **2** Normal position  
**3** Snow position

**3. Set the driving pattern selector switch to the "Normal" position.**

Your transmission has a driving pattern selector switch which allows you to select "Power", "Normal" or "Snow" mode to suit your driving condition. For ordinary driving, Lexus recommends that you use the "Normal" position to improve fuel economy.

**4. For more powerful acceleration and sporty driving, use the "Power" position.**

In the POWER position, the "ECT PWR" light in the instrument cluster is on and the transmission is shifted up at higher vehicle speeds and shifted down more responsively than in the NORMAL position.

**5. For starting your vehicle in sand, mud, ice or snow, use the "Snow" position. For details, see (j) Driving in "Snow" mode on page 298.**

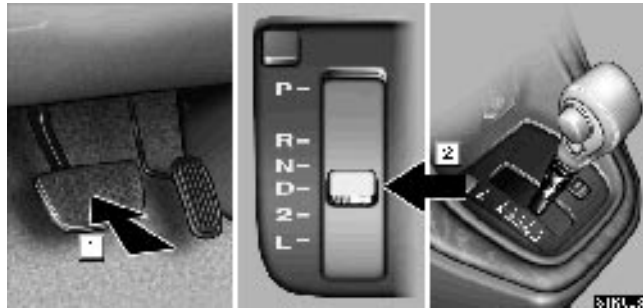

► **1** Brake pedal **2** "D" (Drive) position

**6. With your foot holding down the brake pedal, shift the selector lever to "D".**

	<p><b>CAUTION</b></p>
<p><b>Never put your foot on the accelerator pedal while shifting.</b></p>	

**7. Release the parking brake and brake pedal. Depress the accelerator pedal slowly for smooth starting.**

The vehicle will start in the first gear and automatically shift to the most suitable gear for the running conditions, such as the vehicle speed, hill climbing, hard towing, etc. However, while the engine coolant temperature is low and the vehicle is traveling at low speed, the transmission will not shift into the overdrive gear even with the overdrive switch on.

In "D" position, the automatic transmission system will select the most suitable gear for the running conditions such as hill climbing, hard towing, etc.

If you need to accelerate rapidly while driving, push the accelerator pedal all the way to the floor. The transmission will automatically downshift to the third, second or first gear, according to the vehicle speed.

If engine braking is needed, such as in descending a long hill, see "(b) Using engine braking".

## STARTING AND DRIVING

---

### (b) Using engine braking

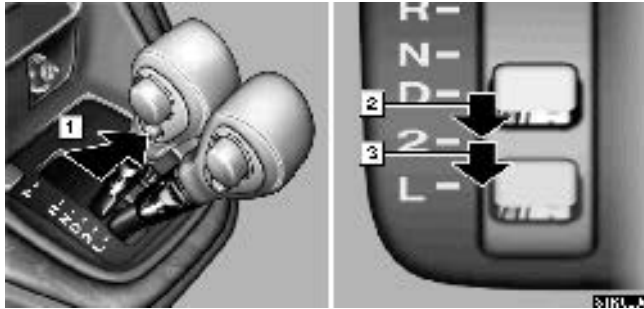

To use the braking power of the engine, downshift the transmission in the way described below:

- 1 Turn off the overdrive switch. (This is effective only when you are driving in the "D" position.) The "O/D OFF" indicator light in the instrument cluster will come on and the transmission will downshift to the third gear and engine braking will be obtained.

When the cruise control is being used, even if you downshift the transmission by turning off the overdrive switch, engine braking will not be applied because the cruise control is not cancelled. If you need to decrease the vehicle speed, see page 302.

- 2 Shift into the "2" position. The transmission will downshift to the second gear when the vehicle speed drops down to or lower than the following speed, and more powerful engine braking will be obtained.

Two-wheel drive models                      105 km/h (65 mph)

Four-wheel drive models                      98 km/h (61 mph)

- 3 Shift into the "L" position. The transmission will downshift to the first gear when the vehicle speed drops down to or lower than the following speed, and maximum engine braking will be applied.

Two-wheel drive models                      48 km/h (30 mph)

Four-wheel drive models                      45 km/h (28 mph)



**CAUTION**

**Be careful when downshifting on a slippery surface. The abrupt change in engine speed could cause the vehicle to spin or skid.**

## STARTING AND DRIVING

---

### (c) Using the "2" and "L" positions

The "2" and "L" positions are used for strong engine braking as described previously.

With the selector lever in "2" or "L", you can start the vehicle in motion as with the lever in "D".

With the selector lever in "2", the vehicle will start in the first gear and automatically shift to the second gear.

With the selector lever in "L", the transmission is engaged in the first gear.

#### **NOTICE**

- *Be careful not to overrev the engine. Watch the tachometer to keep engine rpm from going into the red zone. The approximate maximum allowable speed for each position is given above for your reference.*

#### *Two-wheel drive models:*

"2" ..... 125 km/h (78 mph)

"L" ..... 70 km/h (43 mph)

#### *Four-wheel drive models:*

"2" ..... 117 km/h (73 mph)

"L" ..... 65 km/h (40 mph)

- *Do not continue hill climbing or hard towing for a long time in the "2" or "L" position. This may cause severe automatic transmission damage from overheating. To prevent such damage, "D" position should be used in hill climbing or hard towing.*

(d) Backing up

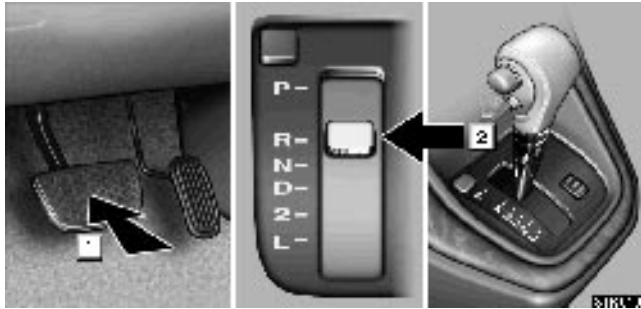

► **1** Brake pedal **2** "R" (Reverse) position

1. Bring the vehicle to a complete stop.
2. With the brake pedal held down with your foot, shift the selector lever to the "R" position.

**NOTICE**

*Never shift into reverse while the vehicle is moving.*



## STARTING AND DRIVING

---

### (e) Parking

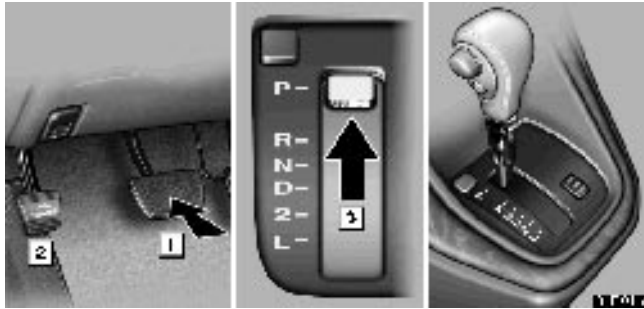

- **1** Brake pedal   **2** Parking brake pedal  
**3** "P" (Park) position

1. Bring the vehicle to a complete stop.
2. Depress the parking brake fully to securely apply the parking brake.
3. With the brake pedal held down with your foot, shift the selector lever to the "P" position.



### CAUTION

**While the vehicle is moving, never attempt to move the selector lever into "P" under any circumstances. Serious mechanical damage and loss of vehicle control may result.**

**(f) Good driving practice**

- If the transmission repeatedly upshifts and downshifts between the third and overdrive gears when climbing a gentle slope, turn off the overdrive switch. Be sure to turn the switch on immediately after climbing the slope.
- When towing a trailer, in order to maintain efficient engine braking and electrical charging performance, do not use overdrive.



**CAUTION**

**Always keep your foot on the brake pedal while stopped with the engine running. This prevents the vehicle from creeping.**

***NOTICE***

*Do not hold the vehicle on an upgrade with the accelerator pedal. This can cause the transmission to overheat. Always use the brake pedal or parking brake.*



**CAUTION**

**If your vehicle becomes stuck in snow, mud, sand, etc., then you may attempt to rock the vehicle free by moving it forward and backward. Do not attempt this procedure if people or objects are anywhere near the vehicle. During the rocking operation the vehicle may suddenly move forward or back as it becomes un-stuck, causing injury or damage to nearby people or objects.**

**(g) Rocking your vehicle if stuck**

## STARTING AND DRIVING

---

### **NOTICE**

*If you rock your vehicle, observe the following precautions to prevent damage to the transmission and other parts.*

- *Do not depress the accelerator pedal while shifting the selector lever or before the transmission is completely shifted to forward or reverse gear.*
- *Do not race the engine and avoid spinning the wheels.*
- *If your vehicle remains stuck after rocking the vehicle several times, consider other ways such as towing.*

#### **(h) If you cannot shift the selector lever out of "P" position**

If you cannot shift the selector lever from "P" position even though the brake pedal is depressed, use the shift lock override button. For instructions, see "If you cannot shift automatic transmission selector lever" on page 375.

#### **(i) If the "O/D OFF" indicator light flashes**

If the "O/D OFF" indicator light flashes, contact your Lexus dealer as soon as possible. There may be trouble in the transmission system.

#### **(j) Driving in "Snow" mode**

In the "Snow" position, the transmission system shifts up from the second gear.

To set the "Snow" mode, push the "Snow" switch. In the "Snow" mode, the "ECT SNOW" indicator light comes on. To cancel the "Snow" mode, push the "Snow" switch again.

The "PWR" mode is automatically cancelled when you push the "Snow" switch.

## CRUISE CONTROL

**The cruise control allows you to cruise the vehicle at a desired speed over 40 km/h (25 mph) with your foot off the accelerator pedal.**

Your cruising speed can be maintained although a slight speed change may occur when driving up or down a gradient, within the limits of engine performance. On steeper hills, a great speed change will occur so it is better to drive without the cruise control.

When the cruise control is on, the driving pattern of the automatic transmission is fixed in the normal position, regardless of the position of the selector switch.



### CAUTION

- **To help maintain maximum control of your vehicle, do not use the cruise control when driving in heavy or varying traffic, or on slippery (rainy, icy or snow-covered) or winding roads.**
- **Avoid vehicle speed increases when driving downhill. If the vehicle speed is too fast in relation to the cruise control set speed, cancel the cruise control then downshift the transmission to use engine braking to slow down.**

## STARTING AND DRIVING

---

### Turning on the system



To operate the cruise control, push the main switch. This turns the system on. The indicator light in the instrument cluster shows that you can now set your desired cruising speed. Another push on the switch will turn the system completely off.

When the ignition key is turned off, the main switch is also automatically turned off. To use the cruise control again, push the main switch again to turn it on.



### CAUTION

**To avoid accidental cruise control engagement, keep the main switch off when not using the cruise control.**

### Setting at a desired speed



The transmission must be in "D" before you set the cruise control speed.

Bring the vehicle to the desired speed, press the control lever downward in the "SET/COAST" direction and release it. This sets the vehicle at that speed. Now you may take your foot off the accelerator pedal. If you need acceleration – for example, when passing – depress the accelerator pedal enough for the vehicle to exceed the set speed. When you release the accelerator pedal, the vehicle will return to the speed set prior to the acceleration.

## STARTING AND DRIVING

---

### Canceling the preset speed

You can cancel the preset speed by either of the following:

- a. Pulling the control lever in the "CANCEL" direction.
- b. Depressing the brake pedal.

If the vehicle speed falls below about 40 km/h (25 mph), the preset speed will be automatically cancelled.

If the vehicle speed drops 16 km/h (10 mph) below the preset speed, the preset speed will also automatically be cancelled.

If the preset speed automatically cancels out for other than these reasons, have your vehicle checked by your Lexus dealer at the earliest opportunity.

### Resetting to a faster speed

Press the control lever upward in the "RES/ACC" direction and hold it. Release the lever when the desired speed is attained. While the lever is held upward, the vehicle will gradually gain speed.

When the difference between the actual vehicle speed and the set speed is less than 5 km/h (3 mph), the set speed can be increased 1.6 km/h (1 mph) each time by pressing the control lever upward in the "RES/ACC" direction quickly.

However, a quicker way to reset is to accelerate the vehicle and then press the control lever downward in the "SET/COAST" direction.

### Resetting to a slower speed

Press the control lever downward in the "SET/COAST" direction and hold it. Release the lever when the desired speed is attained. While the lever is held downward, the vehicle speed will gradually decrease.

When the difference between the actual vehicle speed and the set speed is less than 5 km/h (3 mph), the set speed can be lowered 1.6 km/h (1 mph) each time by pressing the control lever downward in the "SET/COAST" direction quickly.

However, a quicker way to reset is to depress the brake pedal and then press the control lever downward in the "SET/COAST" direction.

Even if you turn off the overdrive switch with the cruise control on, engine braking will not be applied because the cruise control is not cancelled. To decrease the vehicle speed, reset to a slower speed with the cruise control lever or depress the brake pedal. If you use the brake pedal, cruise control is cancelled.

### Resuming the preset speed

If the preset speed is cancelled by pulling the control lever or by depressing the brake pedal, pushing the lever up in the "RES/ACC" direction will restore the speed set prior to cancellation. However, once the vehicle speed falls below about 40 km/h (25 mph), the preset speed will not be resumed.

### **Cruise control failure warning**

If the "CRUISE" indicator light in the instrument cluster flashes when using the cruise control, push the main switch to turn the system off and then push it again to turn it on.

If any of the following conditions then occurs, there is some trouble in the cruise control system.

- The indicator light does not come on.
- The indicator light flashes again.
- The indicator light goes out after it comes on.

If this is the case, contact your Lexus dealer and have your Lexus inspected.

### **TRACTION CONTROL SYSTEM**

**(Two-wheel drive models only)**

**The traction control system automatically helps control the spinning of the front wheels which may occur when accelerating on slippery road surfaces, thus assisting driver to control the driving power of the front wheels.**



## STARTING AND DRIVING

---



When you turn the ignition switch on, this system always turns on. Leave the system on during ordinary driving so that it can operate when needed. When traction control is applied, the slip indicator light blinks.

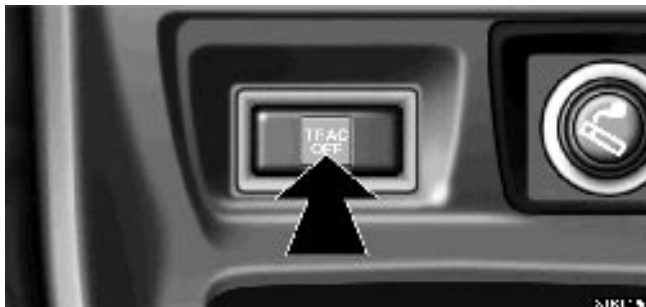

**You can turn off the traction control system by pushing the "TRAC OFF" switch. The "TRAC OFF" indicator/warning light will then come on. Pushing the "TRAC OFF" switch a second time turns the system back on and extinguishes the "TRAC OFF" indicator/warning light.**

You may hear a sound in the engine compartment for a few seconds when the engine is started or just after the vehicle is started. This means that the traction control system is in the self-check mode, and does not indicate malfunction.

When the traction control system is operating, you may feel vibration or noise of your vehicle, caused by operation of the brakes. This indicates the system is functioning properly.

When getting the vehicle out of mud or new snow, etc. the traction control system will help operate to prevent the wheels from spinning.

### **Traction control failure warning**

If the "TRAC OFF" indicator/warning light flashes, contact your Lexus dealer as soon as possible. There may be trouble in the traction control system.



### **CAUTION**

**Under certain slippery road conditions, full traction of the vehicle and power to the front wheels cannot be maintained, even though the traction control system is in operation. Do not drive the vehicle under any speed or maneuvering conditions which will cause the vehicle to lose traction. In situations where the road surface is covered with ice or snow, your vehicle should be fitted with snow tires or tire chains. Always drive at an appropriate and cautious pace.**

## STARTING AND DRIVING

---

### BRAKE SYSTEM

The tandem master cylinder brake system is a hydraulic system with two separate sub-systems. If either sub-system should fail, the other will still work. However, the pedal will be harder to press, and your stopping distance will be longer. Also, the brake system warning light may come on.



#### CAUTION

**Do not drive your vehicle with only a single brake system. Have your brakes fixed immediately.**

#### Brake booster

The brake booster uses engine vacuum to power-assist the brakes. If the engine should quit while you are driving, you can bring the vehicle to a stop with normal pedal pressure. There is enough reserve vacuum for one or two stops but no more!



#### CAUTION

- **Do not pump the brake pedal if the engine stalls. Each push on the pedal uses up your vacuum reserve.**
- **Even if the power assist is completely lost, the brakes will still work. But you will have to push the pedal hard – much harder than normal. And your braking distance will be longer.**

### Anti-lock brake system

**The anti-lock brake system is designed to automatically help prevent lock-up of the wheels during a sudden brake or braking on slippery road surfaces. This assists in providing directional stability and steering performance of the vehicle under these circumstances.**

The anti-lock brake system becomes operative after the vehicle has accelerated to a speed in excess of approximately 10 km/h (6 mph). It stops operating when the vehicle decelerates to a speed below approximately 5 km/h (3 mph).

You may hear a sound in the engine compartment for a few seconds when the engine is started or just after the vehicle is started. This means that the anti-lock brake system is in the self-check mode, and does not indicate a malfunction.

**Effective way to press the ABS brake pedal:** When the anti-lock brake system function is in action, you may feel the brake pedal pulsating and hear a noise. In this situation, to let the anti-lock brake system work for you, just hold the brake pedal down more firmly. Do not pump the brake in a panic stop. Pumping the brake pedal makes the stopping distance longer.

## STARTING AND DRIVING

---

The brake pedal pulsation caused by the anti-lock brake system may indicate hazardous road surface conditions. Although the anti-lock brake system assists in providing vehicle control, it is still important to drive with all due care, because the anti-lock brake system cannot overcome the laws of physics that act on your vehicle:

- Braking capability is dependent on tire friction with the road surface.

- Even though the anti-lock brake system is operating, a driver cannot maintain full control on certain slippery road surfaces, when cornering at high speeds, or in violent maneuvers.
- Avoid high speeds on wet roads. The anti-lock brake system cannot eliminate the risk of hydroplaning and loss of tire friction.

Always maintain a safe distance from the vehicle in front of you. Compared with vehicles not fitted with an anti-lock brake system, your vehicle may require a longer stopping distance in the following cases:

- Driving on rough, gravel or snow-covered roads.
- Driving with tire chains installed.
- Driving on roads where the road surface is pitted or has other differences in surface height.

"ABS" warning light

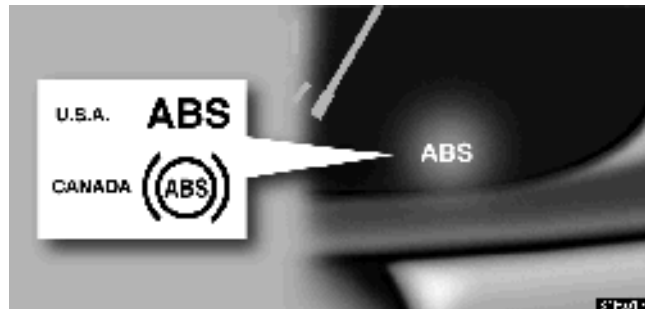

## STARTING AND DRIVING

---

**This light comes on when the ignition key is turned to the "ON" position. After about a few seconds, the light will go off.**

If either of the following conditions occurs, this indicates a malfunction somewhere in the parts monitored by the warning light system. Contact your Lexus dealer as soon as possible to service the vehicle.

- The light does not come on as described above, or remains on.
- The light comes on while driving.

Even if the anti-lock brake system should fail, the brake system will still operate conventionally. But when the "ABS" warning light is on (and the brake system warning light is off), anti-lock brake system is not assisting brake performance so that the wheels could lock up during a sudden brake or braking on slippery road surfaces. Have your vehicle checked by your Lexus dealer as soon as possible.

### **Drum-in-disc type parking brake system**

Your vehicle has a drum-in-disc type parking brake system. This type of brake system needs bedding-down of the brake shoes periodically or whenever the parking brake shoes and/or drums are replaced.

Have your Lexus dealer perform the bedding-down.

## **BRAKE PAD WEAR LIMIT INDICATORS**



**The brake pad wear limit indicators on your disc brakes give a warning noise when the brake pads are worn to the extent that replacement is required.**

If you hear a squealing or scraping noise while driving, have the brake pads checked and replaced by your Lexus dealer as soon as possible. Expensive rotor damage can result if the pads are not replaced when needed.



## STARTING AND DRIVING

---

### TYPES OF TIRES

Determine what kind of tires your vehicle is originally equipped with.

#### 1. Summer tires

Summer tires are high-speed capability tires best suited to highway driving under dry conditions.

Since summer tires do not have the same traction performance as snow tires, summer tires are inadequate for driving on snow-covered or icy roads. For driving on snow-covered or icy roads, we recommend using snow tires. If installing snow tires, be sure to replace all four tires.

#### 2. All season tires

All season tires are designed to provide better traction in snow and to be adequate for driving in most winter conditions, as well as for use all year round.

All season tires, however, do not have adequate traction performance compared with snow tires in heavy or loose snow. Also, all season tires fall short in acceleration and handling performance compared with summer tires in highway driving.



**CAUTION**

- Do not mix summer and all season tires on your vehicle as this can cause dangerous handling characteristics, resulting in loss of control.
- Do not use tires other than the manufacturer's designated tires, and never mix tires or wheels of the sizes different from the originals.



## *SECTION 3 - 2*

---

### **STARTING AND DRIVING**

#### **Driving tips**

Off-road vehicle precautions .....	316
Break-in period .....	318
Operation in foreign countries .....	318
Tips for driving in various conditions .....	318
Off-road driving precautions .....	320
Winter driving tips .....	322
Trailer towing .....	324
How to save fuel and make your vehicle last longer ...	334

## DRIVING TIPS

---

### OFF-ROAD VEHICLE PRECAUTIONS



This vehicle is one of the class of vehicles which have higher ground clearance and narrower tread in relation to the height of their center of gravity to make them capable of performing in a wide variety of off-road applications. Specific design characteristics give it a higher center of gravity than ordinary cars. An advantage of the higher ground clearance is a better view of the road allowing you to anticipate problems. It is not designed for cornering at the same speeds as conventional two-wheel drive vehicles any more than low-slung sports cars are designed to perform satisfactorily under off-road conditions.



**CAUTION**

Always observe the following precautions to minimize the risk of serious personal injury or damage to your vehicle:

- Avoid sharp turns or abrupt maneuvers, if at all possible. As with other vehicles of this type, failure to operate this vehicle correctly may result in loss of control or vehicle rollover.
- Avoid loading any items on the roof that will make the center of gravity even higher.
- Always slow down in gusty crosswinds. Because of its high center of gravity, your vehicle is more sensitive to side winds than an ordinary passenger car. Slowing down will allow you to have much better control.
- Do not drive horizontally across steep slopes. Driving straight up or straight down is preferred. Your vehicle (or any similar off-road vehicle) can tip over sideways much more easily than forward or backward.
- When driving off-road or in rugged terrain, do not drive at excessive speeds, jump the vehicle, or strike objects, etc. This may cause loss of control or vehicle rollover. You are also risking expensive damage to your vehicle's suspension and chassis.

## DRIVING TIPS

---

### BREAK-IN PERIOD

**Drive gently and avoid high speeds.**

You need not follow a break-in schedule with your new Lexus. But following a few simple tips for the first 1600 km (1000 miles) can add to the future economy and long life of your vehicle:

- Do not drive over 88 km/h (55 mph).
- Avoid overrevving. Maintain engine speed between 2000 and 4000 rpm.
- Avoid full-throttle starts.
- Try to avoid hard stops during the first 300 km (200 miles).
- Do not drive for a long time at any single speed, either fast or slow.
- Do not tow a trailer during the first 800 km (500 miles).

### OPERATION IN FOREIGN COUNTRIES

**If you plan to drive your Lexus in another country ...**

**First**, comply with the vehicle registration laws.

**Second**, confirm the availability of the correct fuel (unleaded and minimum octane rating).

### TIPS FOR DRIVING IN VARIOUS CONDITIONS

- Always slow down in gusty crosswinds. This will allow you much better control.
- Drive slowly onto curbs and, if possible, at a right angle. Avoid driving onto high, sharp-edged objects and other road hazards. Failure to do so can lead to severe tire damage resulting in tire bursts.
- When parking on a hill, turn the front wheels until they touch the curb so that the vehicle will not roll. Apply the parking brake, and place the transmission in "P". If necessary, block the wheels.
- Washing your vehicle or driving through deep water may get the brakes wet. To see whether they are wet, check that there is no traffic near you and then press the pedal lightly. If you do not feel a normal braking force, the brakes are probably wet. To dry them, drive the vehicle cautiously while lightly pressing the brake pedal with the parking brake applied. If they still do not work safely, pull to the side of the road and call a Lexus dealer for assistance.



**CAUTION**

- Before driving off, make sure the parking brake is fully released and that the parking brake reminder light is off.
- Do not rest your foot on the brake pedal while driving. It can cause dangerous overheating, needless wear, and poor fuel economy.
- To drive down a long or steep hill, reduce your speed and downshift. Remember, if you ride the brakes excessively, they may overheat and not work properly. See page 292.
- Be careful when accelerating, upshifting, downshifting or braking on a slippery surface. The abrupt change in engine speed, such as sudden acceleration or engine braking, could cause the vehicle to spin or skid.
- Do not drive in excess of the speed limit. Even if the legal speed limit permits it, do not drive over 140 km/h (85 mph) unless your vehicle has high-speed capability tires. Driving over 140 km/h (85 mph) may result in tire failure, loss of control and possible injury. Be sure to consult a tire dealer to determine whether the tires on your vehicle are high-speed capability tires or not before driving at such speeds.

- Do not continue normal driving when the brakes are wet. If they are wet, your vehicle will require a longer stopping distance, and it may pull to one side when the brakes are applied. Also, the parking brake will not hold the vehicle securely.



## **DRIVING TIPS**

---

### **OFF-ROAD DRIVING PRECAUTIONS**

When driving your vehicle off-road, please observe the following precautions to ensure your driving enjoyment and to help prevent the closure of areas to off-road vehicles.

- a. Drive your vehicle only in areas where off-road vehicles are permitted to travel.
- b. Respect private property. Get owner's permission before entering private property.
- c. Do not enter areas that are closed. Honor gates, barriers and signs that restrict travel.
- d. Stay on established roads. When conditions are wet, driving techniques should be changed or travel delayed to prevent damage to roads.

For owners in U.S. mainland, Hawaii and Puerto Rico:

To obtain additional information pertaining to driving your vehicle off-road, consult the following organizations.

- State and Local Parks and Recreation Departments
- State Motor Vehicle Bureau
- Recreational Vehicle Clubs
- U.S. Forest Service and Bureau of Land Management



**CAUTION**

Always observe the following precautions to minimize the risk of serious personal injury or damage to your vehicle:

- Drive carefully when off the road. Do not take unnecessary risks by driving in dangerous places.
- Do not grip the steering wheel spokes when driving off-road. A bad bump could jerk the wheel and injure your hands. Keep both hands and especially your thumbs on the outside of the rim.
- Always check your brakes for effectiveness immediately after driving in sand, mud, water or snow.
- After driving through tall grass, mud, rock, sand, rivers, etc., check that there is no grass, bush, paper, rags, stone, sand, etc. adhering or trapped on the underbody. Clear off any such matter from the underbody. If the vehicle is used with these materials trapped or adhering to the underbody, a breakdown or fire could occur.
- The driver and all passengers should fasten their seat belts whenever the vehicle is moving.

## DRIVING TIPS

---

### NOTICE

- *If driving through water, such as when crossing shallow streams, first check the depth of the water and the bottom of the river bed for firmness. Drive slowly and avoid deep water.*

- *Take all necessary safety measures to ensure that damage to the engine or other components does not occur.*

*Water entering the engine air intake will cause severe engine damage.*

*Water can wash the grease from wheel bearings, causing rusting and premature failure, and may also enter the differentials, transmission and transfer case, reducing the gear oil's lubricating qualities.*

- *Sand and mud that has accumulated in brake drums and around brake discs may affect braking efficiency and may damage brake system components.*

- *Always perform a maintenance inspection after each day of off-road driving that has taken you through rough terrain, sand, mud, or water. For scheduled maintenance information, refer to the separate "Owner's Manual Supplement/Maintenance Schedule".*

## WINTER DRIVING TIPS

### **Make sure you have a proper freeze protection of engine coolant.**

Your coolant must contain ethylene-glycol type coolant for a proper corrosion protection of aluminum components. Use "Toyota Long Life Coolant" or equivalent. See "Checking the engine coolant level" on page 411 for instructions.

### NOTICE

***Do not use alcohol type antifreeze or plain water alone.***

When it is extremely cold, we recommend to use 60% solution for your Lexus, to provide protection down to about  $-50^{\circ}\text{C}$  ( $-58^{\circ}\text{F}$ ). Do not use more than 70% solution for better coolant performance.

### **Check the condition of the battery and cables.**

Cold temperatures reduce the capacity of any battery, so it must be in top shape to provide enough power for winter starting. Page 443 tells you how to visually inspect the battery. Your Lexus dealer and most service stations will be pleased to check the battery charge level.

### **Make sure the engine oil viscosity is suitable for the cold weather.**

See page 410 for recommended viscosity. Leaving a heavy summer oil in your vehicle during winter months may cause harder starting. If you are not sure about which oil to use, call

your Lexus dealer – they will be pleased to help.

**Check the electronic ignition system for loose connections or obvious damage.**

**Keep the door locks from freezing.**

Squirt lock de-icer or glycerine into the locks to keep them from freezing.

**Use a washer fluid containing an antifreeze solution.**

This product is available at your Lexus dealer and most auto parts stores. Follow the manufacturer's directions for how much to mix with water.

***NOTICE***

***Do not use engine antifreeze or any other substitute because it may damage your vehicle's paint.***

**Do not use your parking brake when there is a possibility it could freeze.**

When parking, put the transmission into "P" and block the rear wheels. Do not use the parking brake, or snow or water accumulated in and around the parking brake mechanism may freeze the parking brake, making it hard to release.

**Keep ice and snow from accumulating under the fenders.**

Ice and snow built up under your fenders can make steering difficult. During bad winter driving, stop and check under the fenders occasionally.

**Depending on where you are driving, we recommend you carry some emergency equipment.**

## DRIVING TIPS

---

Some of the things you might put in the vehicle are tire chains, window scraper, bag of sand or salt, flares, small shovel, jumper cables, etc.

## TRAILER TOWING

Your vehicle is designed primarily as a passenger-and-load carrying vehicle. Towing a trailer will have an adverse effect on handling, performance, braking, durability and driving economy (fuel consumption, etc.). Your safety and satisfaction depend on the proper use of correct equipment and cautious driving habits. For your safety and the safety of others, you must not overload your vehicle or trailer. Lexus warranties do not apply to damage or malfunction caused by towing a trailer for commercial purposes. Ask your local Lexus dealer for further details before towing.

### ***NOTICE***

*When towing a trailer, be sure to consult your Lexus dealer for further information on additional requirements such as a towing kit, etc.*

### Weight limits

**Before towing, make sure the total trailer weight, gross vehicle weight, gross axle weight and trailer tongue load are all within the limits.**

The total trailer weight and tongue load can be measured with platform scales found at a highway weighing station, building supply company, trucking company, junk yard, etc.

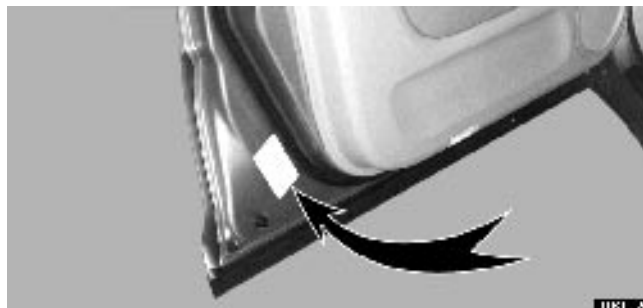

► *Certification label*



## DRIVING TIPS

---

- **The total trailer weight (trailer weight plus its cargo load) must not exceed 1588 kg (3500 lb.). Exceeding this weight is dangerous.**
- **The gross combination weight (sum of your vehicle weight plus its load and the total trailer weight) must not exceed 3629 kg (8000 lb.).**

- **Trailer hitch assemblies have different weight capacities established by the hitch manufacturer. Even though the vehicle may be physically capable of towing a higher weight, the operator must determine the maximum weight rating of the particular hitch assembly and never exceed the maximum weight rating specified for the trailer hitch. Exceeding the maximum weight rating set by the trailer hitch manufacturer can cause an accident resulting in serious personal injuries.**
- **The gross vehicle weight must not exceed the Gross Vehicle Weight Rating (GVWR) indicated on the Certification Label. The gross vehicle weight is the sum weight of the unloaded vehicle, driver, passengers, luggage, hitch and trailer tongue load. It also includes the weight of any special equipment installed on your vehicle.**
- **The load on either the front or rear axle resulting from distribution of the gross vehicle weight on both axles must not exceed the Gross Axle Weight Rating (GAWR) listed on the Certification Label.**

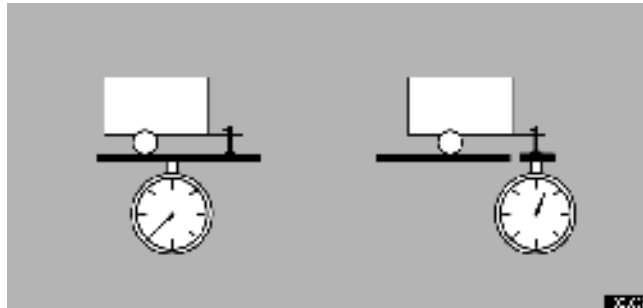

► *Total trailer weight*

► *Tongue load*

- The trailer cargo load should be distributed so that the tongue load is 9 to 11 % of the total trailer weight, not exceeding the maximum of 90 kg (200 lb.).
- Never load the trailer with more weight in the back than in the front. About 60 % of the trailer load should be in the front half of the trailer and the remaining 40 % in the rear.



## DRIVING TIPS

---

### Hitches

- If you wish to install a trailer hitch, your Lexus dealer should be consulted.
- Use only a hitch which is recommended by Lexus dealer and conforms to the total trailer weight requirement.
- Follow the directions supplied by the hitch manufacturer. Lubricate the hitch ball with a light coat of grease.
- Lexus recommends removing the trailer hitch whenever you are not towing a trailer to reduce the possibility of additional damage caused by the hitch if your vehicle is struck from behind. After removing the hitch, seal any mounting holes in the vehicle body to prevent entry of pollutants such as exhaust fumes, dirt, water, etc.

#### ***NOTICE***

- *Install the trailer hitch using only the position recommended by your Lexus dealer. Do not install the trailer hitch on the bumper; this may cause body damage.*
- *Do not use axle-mounted hitches as they can cause damage to the axle housing, wheel bearings, wheels or tires.*

### Brakes and safety chains

- Lexus recommends trailers with brakes that conform to any applicable federal and state/provincial regulations.
- A safety chain must always be used between the towing vehicle and the trailer. Leave sufficient slack in the chain for turns. The chain should cross under the trailer tongue to prevent the tongue from dropping to the ground in case it becomes damaged or separated. For correct safety chain procedures, follow the hitch or trailer manufacturer's recommendations.



#### CAUTION

- If the total trailer weight exceeds 450 kg (1000 lb.), trailer brakes are required.
- Never tap into your vehicle's hydraulic system as it will lower its braking effectiveness.
- Never tow a trailer without using a safety chain securely attached to both the trailer and the vehicle. If damage occurs to the coupling unit or hitch ball, there is possible danger of the trailer wandering over into another lane.

## DRIVING TIPS

---

### Tires

- Ensure that your vehicle's tires are properly inflated. Adjust the tire pressure to the recommended cold tire pressure indicated below:

Tire pressure, kPa (kgf/cm<sup>2</sup> or bar, psi)

Front 210 (2.1, 30)

Rear 210 (2.1, 30)

- The trailer tires should be inflated to the pressure recommended by the trailer manufacturer in respect to the total trailer weight.

### Trailer lights

- Trailer lights must comply with federal, state/provincial and local regulations. See your local recreational vehicle dealer or rental agency for the correct type of wiring and relays for your trailer. Check for correct operation of the turn signals and stop lights each time you hitch up. Direct splicing may damage your vehicle's electrical system and cause a malfunction of your lights.

### Break-in schedule

- Lexus recommends that you do not tow a trailer with a new vehicle or a vehicle with any new power train component (engine, transmission, differential, wheel bearing, etc.) for the first 800 km (500 miles) of driving.

### Maintenance

- If you tow a trailer, your vehicle will require more frequent maintenance due to the additional load. For this information, please refer to the scheduled maintenance information in the "Owner's Manual Supplement/Maintenance Schedule".
- Retighten all fixing bolts of the towing ball and bracket after approximately 1000 km (600 miles) of trailer driving.

### Pre-towing safety check

- Check that your vehicle remains level when a loaded or unloaded trailer is hitched. Do not drive if the vehicle has an abnormal nose-up or nose-down condition, and check for improper tongue load, overload, worn suspension or other possible causes.
- Make sure the trailer cargo is securely loaded so that it cannot shift.
- Check that your rear view mirrors conform to any federal, state/provincial or local regulation. If they do not, install required rear view mirrors appropriate for towing purposes.

### Trailer towing tips

**When towing a trailer, your vehicle will handle differently than when not towing. The three main causes of vehicle–trailer accidents are driver error, excessive speed and improper trailer loading. Keep these in mind when towing:**

- Before starting out, check the operation of the lights and all vehicle–trailer connections. After driving a short distance, stop and recheck the lights and connections. Practice turning, stopping and backing with a trailer in an area away from traffic until you learn the feel.
- Backing with a trailer is difficult and requires practice. Grip the bottom of the steering wheel and move your hand to the left to move the trailer to the left. Move your hand to the right to move the trailer to the right. (This procedure is generally opposite to that when backing without a trailer.) Also, just turn the steering wheel a little at a time, avoiding sharp or prolonged turning. Have someone guide you when backing to reduce the risk of an accident.
- Because stopping distance may be increased, vehicle–to–vehicle distance should be increased when towing a trailer. For each 16 km/h (10 mph) of speed, allow at least one vehicle and trailer length between you and the vehicle ahead. Avoid sudden braking as you may skid, resulting in jackknifing and loss of control. This is especially true on wet or slippery surfaces.
- Avoid jerky starts or sudden acceleration.
- Avoid jerky steering and sharp turns. The trailer could hit your vehicle in a tight turn. Slow down before making a turn to avoid the need of sudden braking.
- Remember that when making a turn, the trailer wheels will be closer than the vehicle wheels to the inside of the turn. Therefore, compensate for this by making a larger than normal turning radius with your vehicle.
- Crosswinds and rough roads will adversely affect handling of your vehicle and trailer, causing sway. Pay attention to the rear from time to time to prepare yourself for being passed by large trucks or buses, which may cause your vehicle and trailer to sway. If swaying happens, firmly grip the steering wheel and reduce speed immediately but gradually. Never increase speed. If it is necessary to reduce speed, brake slowly. Steer straight ahead. If you make no extreme correction with the steering or brakes, your vehicle and trailer will stabilize.
- Be careful when passing other vehicles. Passing requires considerable distance. After passing a vehicle, do not forget the length of your trailer and be sure you have plenty of room before changing lanes.
- In order to maintain efficient engine braking and electrical charging performance, do not use overdrive.
- Because of the added load of the trailer, your vehicle’s engine may overheat on hot days (at temperatures over 30°C [85°F]) when going up a long or steep grade with a trailer. If the engine coolant temperature gauge indicates overheating, immediately turn off the air conditioning (if

## DRIVING TIPS

---

in use), pull your vehicle off the road and stop in a safe spot. See "If your vehicle overheats" on page 343 of this manual.

- Always place wheel blocks under both the vehicle and trailer wheels when parking. Apply the parking brake firmly. Put the transmission in "P". Avoid parking on a slope with a trailer, but if it cannot be avoided, do so only after performing the following:
  1. Apply the brakes and keep them applied.
  2. Have someone place wheel blocks under both the vehicle and trailer wheels.
  3. When the wheel blocks are in place, release your brakes slowly until the blocks absorb the load.
  4. Apply the parking brake firmly.
  5. Shift into "P" and turn off the engine.

When restarting out after parking on a slope:

1. With the transmission in "P" position, start the engine. Be sure to keep the brake pedal depressed.
2. Shift into the "2", "L" or "R" position.
3. Release the parking brake and brake pedal and slowly pull or back away from the wheel blocks. Stop and apply your brakes.
4. Have someone retrieve the blocks.



**CAUTION**

- Do not exceed 72 km/h (45 mph) or the posted towing speed limit, whichever is lower. Because instability (swaying) of a towing vehicle-trailer combination usually increases as the speed increases, exceeding 72 km/h (45 mph) may cause loss of control.
- Slow down and downshift before descending steep or long downhill grades. Do not make sudden downshifts.
- Avoid holding the brake pedal down too long or too frequently. This could cause the brakes to overheat and result in reduced braking efficiency.

## DRIVING TIPS

---

### HOW TO SAVE FUEL AND MAKE YOUR VEHICLE LAST LONGER

Getting more kilometer/mileage from a liter/gallon of fuel is easy – just take it easy. It will help make your vehicle last longer, too. Here are some specific tips on how to save money on both fuel and repairs:

- **Keep your tires inflated at the correct pressure.** Check the pressure every two weeks, or at least once a month. Underinflation causes tire wear and wastes fuel.
- **Do not carry unneeded weight in your vehicle.** Excess weight puts a heavier load on the engine, causing greater fuel consumption.
- **Avoid lengthy warm-up idling.** Once the engine is running smoothly, begin driving – but gently. Remember, however, that on cold winter days this may take a little longer.
- **Accelerate slowly and smoothly.** Avoid jackrabbit starts.
- **Avoid long engine idling.** If you have a long wait and you are not in traffic, it is better to turn off the engine and start again later.
- **Avoid engine overrevving.** Use a gear position suitable for the road on which you are traveling.
- **Avoid continuous speeding up and slowing down.** Stop-and-go driving wastes fuel.
- **Avoid unnecessary stopping and braking.** Maintain a steady pace. Try to time the traffic signals so you only need to stop as little as possible or take advantage of through streets to avoid traffic lights. Keep a proper distance from other vehicles to avoid sudden braking. This will also reduce wear on your brakes.
- **Avoid heavy traffic or traffic jams whenever possible.**
- **Do not rest your foot on the brake pedal.** This causes needless wear, overheating and poor fuel economy.
- **Maintain a moderate speed on highways.** The faster you drive, the greater the fuel consumption. By reducing your speed, you will cut down on fuel consumption.
- **Keep the front wheels in proper alignment.** Avoid hitting the curb and slow down on rough roads. Improper alignment not only causes faster tire wear but also puts an extra load on the engine, which, in turn, wastes fuel.
- **Keep the bottom of your vehicle free from mud, etc.** This not only lessens weight but also helps prevent corrosion.

- **Keep your vehicle tuned-up and in top shape.** A dirty air cleaner, improper valve clearance, dirty plugs, dirty oil and grease, brakes not adjusted, etc. all lower engine performance and contribute to poor fuel economy. For longer life of all parts and lower operating costs, keep all maintenance work on schedule, and if you often drive under severe conditions, see that your vehicle receives more frequent maintenance. (For scheduled maintenance information, please refer to the separate "Owner's Manual Supplement/Maintenance Schedule".)



### CAUTION

**Never turn off the engine to coast down hills. Your power steering and brake booster will not function without the engine running. Also, the emission control system operates properly only when the engine is running.**



## **SECTION 4**

---

### **IN CASE OF AN EMERGENCY**

If your engine stalls while driving .....	337
If your vehicle will not start .....	338
If your vehicle overheats .....	343
If you have a flat tire .....	346
If your vehicle needs to be towed .....	364
If you cannot shift automatic transmission selector lever	375
If you lose your keys or lock yourself out .....	377

## IF YOUR ENGINE STALLS WHILE DRIVING

**If your engine stalls while driving . . . .**

1. Reduce your speed gradually, keeping a straight line.  
Move cautiously off the road to a safe place.
2. Turn on your emergency flashers.
3. Try starting the engine again.

If the engine will not start, see "If your vehicle will not start".



### CAUTION

**If the engine is not running, the power assist for the brakes and steering will not work, so steering and braking will be much harder than usual.**

## IN CASE OF AN EMERGENCY

---

### IF YOUR VEHICLE WILL NOT START

#### (a) Simple checks

Before making these checks, make sure you have followed the correct starting procedure instructions in "How to start the engine" on page 285 and that you have sufficient fuel. Since your vehicle is equipped with the engine immobiliser system, also check whether the other keys will start the engine. If they work, your key may be broken. Have the key checked at your Lexus dealer. If none of your keys work, the system is possibly broken. Call your Lexus dealer. See "Keys" on page 8.

**If the engine is not turning over or is turning over too slowly –**

1. Check that the battery terminals are tight and clean.
2. If the battery terminals are O.K., switch on the interior light.
3. If the light is out, dim or goes out when the starter is cranked, the battery is discharged. You may try jump starting. See "(c) Jump starting" for further instruction.

If the light is O.K., but the engine still will not start, it needs adjustment or repair. Call a Lexus dealer, Roadside Assistance or Customer Service Assistance. (See "Foreword".)

#### **NOTICE**

*Do not pull- or push-start the vehicle. It may damage the vehicle or cause a collision when the engine starts. Also the three-way catalytic converter / warm up three-way catalytic converter may overheat and become a fire hazard.*

**If the engine turns over at its normal speed but will not start –**

1. The engine may be flooded because of repeated cranking. See "(b) Starting a flooded engine" for further instructions.
2. If the engine still will not start, it needs adjustment or repair. Call a Lexus dealer, Roadside Assistance or Customer Service Assistance. (See "Foreword".)

**(b) Starting a flooded engine**

**If the engine will not start, your engine may be flooded because of repeated cranking.**

If this happens, turn the key to "START" with the accelerator pedal held down. Continue this operation for 30 seconds and then stop cranking. Then try starting the engine with your foot off the accelerator pedal.

If the engine does not start after 30 seconds of cranking, release the key, wait a few minutes and try again.

If the engine still will not start, it needs adjustment or repair. Call a Lexus dealer, Roadside Assistance or Customer Service Assistance. (See "Foreword".)

**(c) Jump starting**

**To avoid serious personal injury and damage to your vehicle which might result from battery explosion, acid burns, electrical burns, or damaged electronic components, these instructions must be followed precisely.**

If you are unsure about how to follow this procedure, we strongly recommend that you seek help from your Lexus dealer, Roadside Assistance or Customer Service Assistance. (See "Foreword".)

***NOTICE***

***Do not crank for more than 30 seconds at a time. This may overheat the starter and wiring systems.***

## IN CASE OF AN EMERGENCY

---



### CAUTION

- Batteries contain sulfuric acid which is poisonous and corrosive. Wear protective safety glasses when jump starting, and avoid spilling acid on your skin, clothing, or vehicle.
- If you should accidentally get acid on yourself or in your eyes, remove any contaminated clothing and flush the affected area with water immediately. Then get immediate medical attention. If possible, continue to apply water with a sponge or cloth while en route to the medical office.
- The gas normally produced by a battery will explode if a flame or spark is brought near. Use only standardized jumper cables and do not smoke or light a match while jump starting.



## IN CASE OF AN EMERGENCY

---

► **5** *Discharged battery* **6** *Booster battery*

### JUMP STARTING PROCEDURE

1. If the booster battery is installed in another vehicle, make sure the vehicles are not touching. Turn off all unnecessary lights and accessories.
2. If required, remove all the vent plugs from the booster battery. Lay a cloth over the open vents on the booster battery. (This helps reduce the explosion hazard, personal injuries and burns.)
3. If the engine in the vehicle with the booster battery is not running, start it and let it run for about 5 minutes. During jump starting, run the engine at about 2000 rpm with the accelerator pedal lightly depressed.
4. Locate positive (+) and negative (-) terminals of each battery. Connect the jumper cables in the exact order ( **1** **2** **3** **4** ) shown in the illustration.
  - 1** Connect a positive (red) jumper cable clamp to the positive (+) terminal of the discharged battery.
  - 2** Connect the clamp at the other end of the positive (red) cable to the positive (+) terminal of the booster battery.
  - 3** Connect a negative (black) cable clamp to the negative (-) terminal of the booster battery.
  - 4** Connect the clamp at the other end of the negative (black) cable to a solid, stationary, unpainted metallic point (e.g. engine cover tightening bolt) away from the battery. Do not connect it to or near any part that moves when the engine is cranked.



**CAUTION**

**When making the connections, to avoid serious injury, do not lean over the battery or accidentally let the jumper cables or clamps touch anything except the correct battery terminals or the ground.**

5. Start your engine in the normal way. After starting, run it at about 2000 rpm for several minutes with the accelerator pedal lightly depressed.
6. Carefully disconnect the cables in the exact reverse order: the negative cable and then the positive cable.
7. Carefully dispose of the battery cover cloths which may now contain sulfuric acid.
8. If removed, replace all the battery vent plugs.

If the cause of your battery discharging is not apparent (for example, lights left on), you should have it checked.

## **IF YOUR VEHICLE OVERHEATS**

**If your engine coolant temperature gauge indicates overheating, if you experience a loss of power, or if you hear a loud knocking or pinging noise, the engine has probably overheated.**



## IN CASE OF AN EMERGENCY

---

### When the engine overheats

Pull safely off the road, stop the vehicle and turn on your emergency flashers. Put the transmission in "P" and apply the parking brake.

**A: If steam is coming from your engine:**

Turn off the engine. Leave the hood closed until there is no sign of steam or coolant. Your engine could have been seriously damaged already. Call your Lexus dealer for assistance.



### CAUTION

**To help avoid personal injury, keep the hood closed until there is no steam. Escaping steam or coolant is sign of very high pressure.**

**B: If no steam is coming from your engine:**

Leave the engine running and turn off the air conditioning.  
Check the following.

- Is the cooling fan operating?
- Is the coolant in the acceptable range?
- Is the engine drive belt O.K.?

	<b>CAUTION</b>
<ul style="list-style-type: none"><li>● <b>When the engine is running, keep hands and clothing away from the moving fan and engine drive belt.</b></li><li>● <b>Do not attempt to remove the radiator cap when the engine and radiator are hot. Serious injury could result from scalding hot fluid and steam blown out under pressure.</b></li></ul>	

If the cooling fan is not operating or the coolant is not in the acceptable range, turn off the engine and call your Lexus dealer.

If both conditions are O.K., after the engine coolant temperature has cooled to normal, continue driving your vehicle.

If the engine coolant temperature does not cool down, or your vehicle overheats again, have it checked as soon as possible by your Lexus dealer.

## IN CASE OF AN EMERGENCY

---

### IF YOU HAVE A FLAT TIRE

1. Reduce your speed gradually, keeping a straight line. Move cautiously off the road to a safe place – well away from the traffic. Avoid stopping on the center divider of a highway. Park on a level spot with firm ground.
2. Stop the engine and turn on your emergency flashers.
3. Firmly set the parking brake and put the transmission in "P".
4. Have everyone get out of the vehicle on the side away from traffic.
5. Read the following instructions thoroughly.



#### CAUTION

When jacking, be sure to observe the following to reduce the possibility of personal injury:

- Follow jacking instructions.
- Do not put any part of your body under a vehicle supported by a jack. Personal injury may occur.
- Do not start or run the engine while your vehicle is supported by the jack.
- Stop the vehicle on a level firm ground, firmly set the parking brake and put the transmission in "P". Block the wheel diagonally opposite to the one being changed if necessary.

## IN CASE OF AN EMERGENCY

- Make sure to set the jack properly in the jack point. Raising the vehicle with jack improperly positioned will damage the vehicle or may allow the vehicle to fall off the jack and cause personal injury.
- Never get under the vehicle when the vehicle is supported by the jack alone.
- Use the jack only for lifting your vehicle during wheel changing.
- Do not raise the vehicle with someone in the vehicle.
- When raising the vehicle, do not put an object on or under the jack.
- Raise the vehicle only high enough to remove and change the tire.

### *NOTICE*

*Do not continue driving with a deflated tire. Driving even a short distance can damage a tire beyond repair.*

Access to spare tire

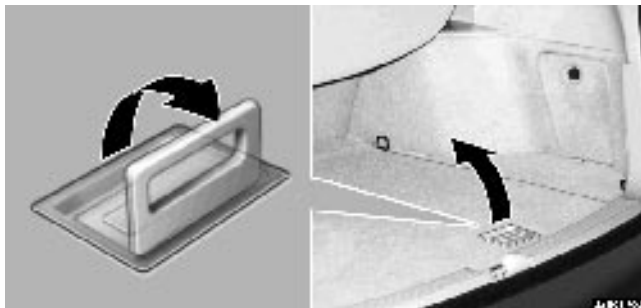

**IN CASE OF AN EMERGENCY**

---

- 1. Pull up the deck board.**

## IN CASE OF AN EMERGENCY

---

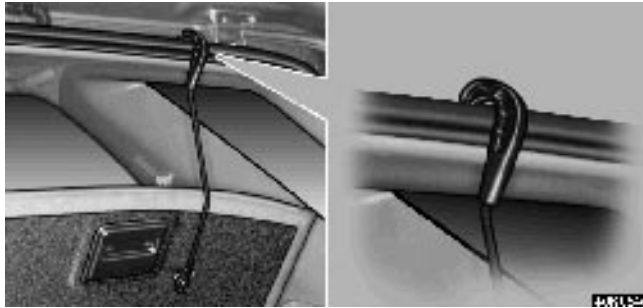

**2. Take off the hook at the rear of the deck board.**

**3. Lift up the back side of the board and secure the board by hooking it at the top of the back door opening with the hook at the edge of the strap.**

Make sure the board is secured and does not fall down.

## IN CASE OF AN EMERGENCY

---



When closing the board, replace the hook also in its original position as shown.

Changing procedure

### **NOTICE**

*If you close the back door with the board hooked, the hook may be damaged.*

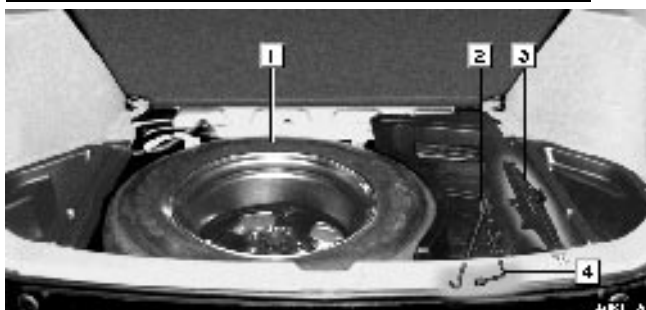

► **1** *Spare tire* **2** *Jack handle* **3** *Jack* **4** *Wrench*

**1. Get the jack, wrench and spare tire.**

To prepare yourself for an emergency, you should familiarize yourself with the use of the jack and each tool, and their storage locations. The jack is located under the tray for the jack handle and wrench.



## IN CASE OF AN EMERGENCY

---

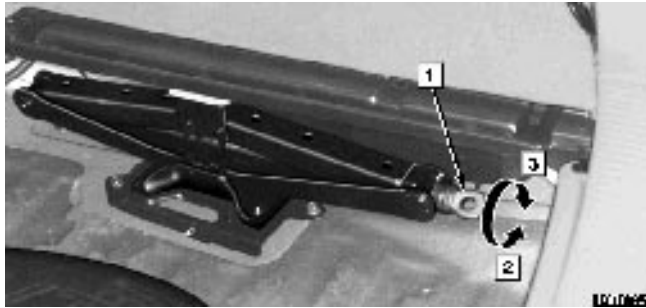

► **1** *Joint*

- 2** When removing the jack, turn the joint by hand in the "contract" direction until the jack is free.
- 3** When storing, turn the joint by hand in the "expand" direction until the jack is firmly secured to prevent it from flying forward during a collision or sudden braking.

## IN CASE OF AN EMERGENCY

---



To remove the spare tire:

- 1 Remove the spare tire cover.
- 2 Loosen the bolt and remove it.

When storing the spare tire, place it with the inner side of the wheel facing up. Then bolt the tire in place and install the spare tire cover to prevent the tire from flying forward during a collision or sudden braking.

## IN CASE OF AN EMERGENCY

---



**2. Block the wheel diagonally opposite the flat tire to keep the vehicle from rolling when it is jacked up.**

When blocking the wheel, place a wheel block in front of the front wheels or behind the rear wheels.



**3. Loosen all the wheel nuts.**

Always loosen the wheel nuts before raising the vehicle.

Turn the nuts counterclockwise to loosen them. To get maximum leverage, fit the wrench to the nut so that the handle is on the right side, as shown above. Grab the wrench near the end of the handle and pull up on the handle. Be careful that the wrench does not slip off the nut.

Do not remove the nuts yet – just unscrew them about one-half turn.

## IN CASE OF AN EMERGENCY

---

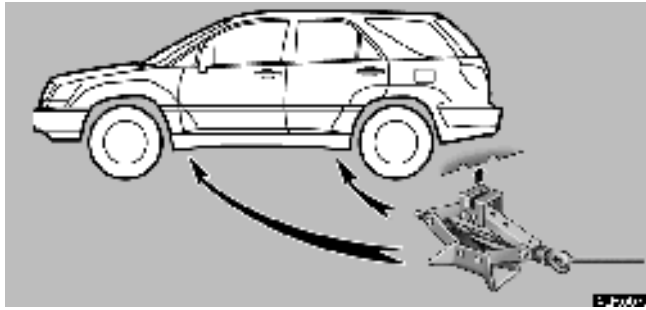

### **4. Position the jack at the jack points as shown.**

Make sure the jack is positioned on a level and solid surface.

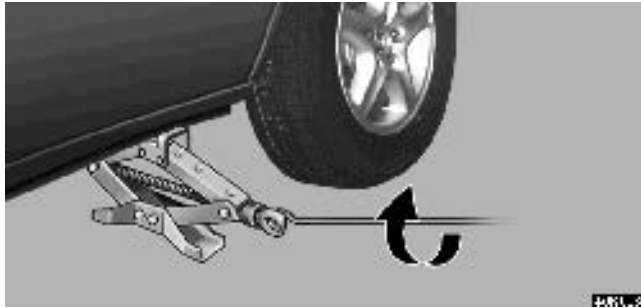

**5. After making sure no one is in the vehicle, raise it high enough so that the spare tire can be installed.**

Allow for the fact that you need more ground clearance when putting on the spare tire than when removing the flat tire.

To raise the vehicle, insert the jack handle into the jack (it is a loose fit) and turn it clockwise. As the jack touches the vehicle and begins to lift, double-check that it is properly positioned.

## IN CASE OF AN EMERGENCY

---



### CAUTION

Never get under the vehicle when the vehicle is supported by the jack alone.



**6. Remove the wheel nuts and remove the flat tire.**

Lift the flat tire straight off and put it aside.

## IN CASE OF AN EMERGENCY

---

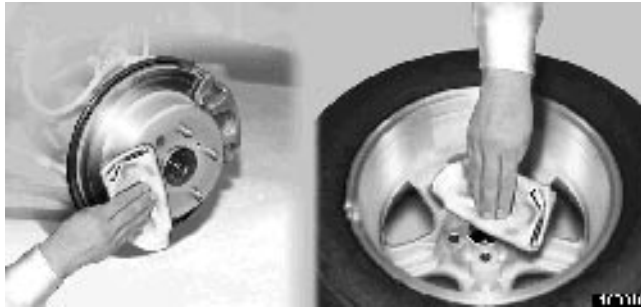

Before putting on the wheel, remove any corrosion on the mounting surfaces with a wire brush or such. Installation of wheels without good metal-to-metal contact at the mounting surface can cause wheel nuts to loosen and eventually cause a wheel to come off while driving.



## IN CASE OF AN EMERGENCY

---



### **7. Reinstall all the wheel nuts finger tight.**

Align the holes in the wheel with the bolts. Then lift up the wheel and get at least the top bolt started through its hole. Wiggle the tire and press it back over the other bolts.

Reinstall the wheel nuts and tighten them as much as you can by hand. Press the tire back and see if you can tighten them more.



**8. Lower the vehicle completely and tighten the wheel nuts.**

Turn the jack handle counterclockwise to lower the vehicle.

Use only the wheel nut wrench to tighten the nuts. Do not use other tools or any additional leverage other than your hands, such as a hammer, pipe or your foot. Make sure the wrench is securely engaged over the nut.

Tighten each nut a little at a time in the order shown. Repeat the process until all the nuts are tight.

## IN CASE OF AN EMERGENCY

---



### CAUTION

- When lowering the vehicle, make sure all portions of your body and all other persons around will not be injured as the vehicle is lowered to the ground.
- As soon as possible after changing wheels, have the wheel nuts tightened by torque wrench at 103 N·m (10.5 kgf·m, 76 ft·lbf.).

**9. After changing the wheel, check the air pressure of the replaced tire. Stow all the tools, jack and flat tire securely.**

If the pressure of the replaced tire is low, drive slowly to the nearest service station and fill to the correct pressure.

Do not forget to reinstall the tire valve cap as dirt and moisture could get into the valve core and possible cause air leakage. If the cap is missing, put a new one on as soon as possible.

This is the same procedure for changing or rotating your tires.



**CAUTION**

**Before driving, make sure all the tools, jack and flat tire are securely in place in their storage location to reduce the possibility of personal injury during a collision or sudden braking.**

## IN CASE OF AN EMERGENCY

---

### **IF YOUR VEHICLE NEEDS TO BE TOWED**

**If towing is necessary, we recommend you to have it done by your Lexus dealer or a commercial tow truck service. In consultation with them, have your vehicle towed using either (a) or (b).**

- (a) Towing with a wheel lift type truck
- (b) Using a flat bed truck
- (c) Never tow with a sling type truck

**Only when you cannot receive a towing service from a Lexus dealer or commercial tow truck service, tow your vehicle carefully in accordance with the instructions given in "(d) Emergency towing" on page 371.**

Proper equipment will help ensure that your vehicle is not damaged while being towed. Commercial operators are generally aware of the state/provincial and local laws pertaining to towing.

Your vehicle can be damaged if it is towed incorrectly. Although most operators know the correct procedure, it is possible to make a mistake. To avoid damage to your vehicle, make sure the following few precautions are observed. If necessary, show this page to the tow truck driver.

#### **TOWING PRECAUTIONS:**

Use a safety chain system for all towing, and abide by the state/provincial and local laws. The wheels and axle on the

ground must be in good condition. If they are damaged, use a towing dolly.

(a) Towing with a wheel lift type truck

- From front

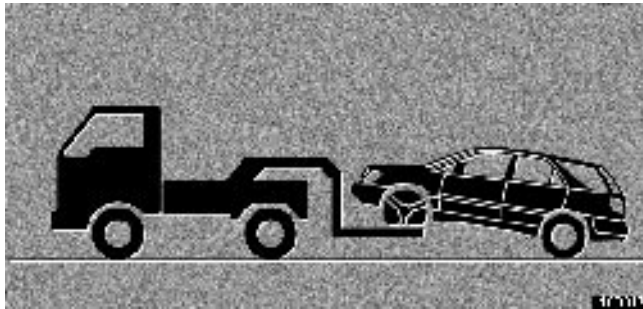

▶ *Two-wheel drive models*

## IN CASE OF AN EMERGENCY

---

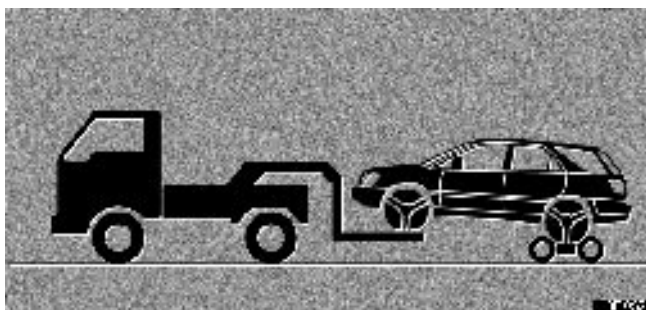

► *Four-wheel drive models*

● From rear

Release the parking brake.

### **NOTICE**

*When lifting wheels, take care to ensure adequate ground clearance for towing at the opposite end of the raised vehicle. Otherwise, the bumper and/or underbody of the towed vehicle will be damaged during towing.*

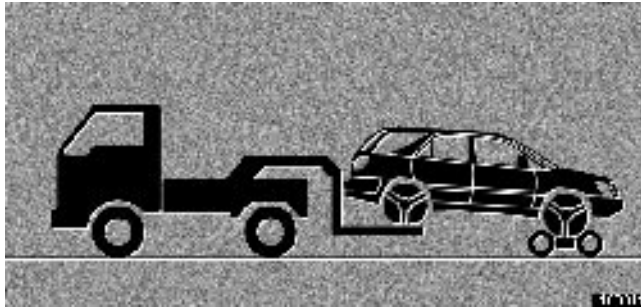

Use a towing dolly under the front wheels.

(b) Using a flat bed truck

***NOTICE***

*Never tow a vehicle with an automatic transmission from the rear with front wheels on the ground, as this may cause serious damage to the transmission.*



## IN CASE OF AN EMERGENCY

---

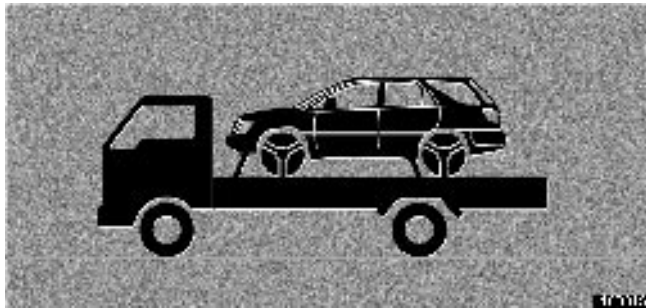

- Tie down points

**IN CASE OF AN EMERGENCY**

---

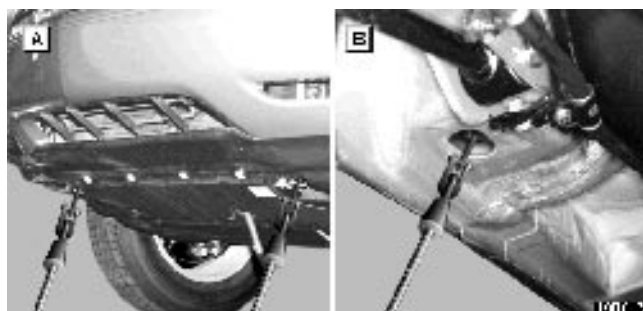
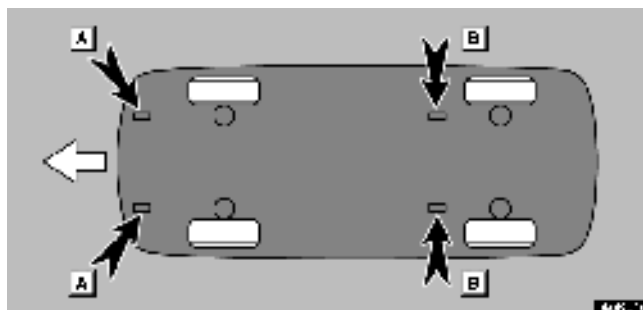

**If your Lexus is transported by a flat bed, it should be tied down at locations A and B as shown above.**

## IN CASE OF AN EMERGENCY

---



► *Rear emergency towing eyelets*

- Tie down angle

### ***NOTICE***

*Do not use the rear emergency towing eyelets.*

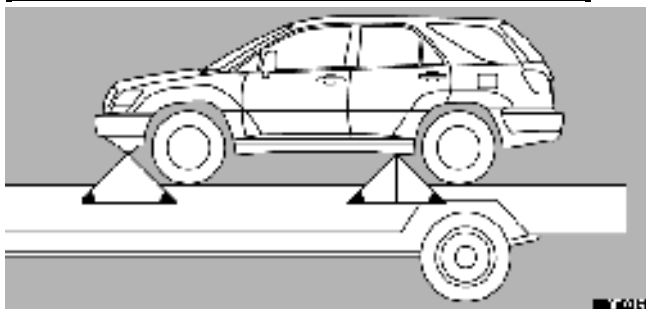

If you use chains or wires to tie down your vehicle, the angles shaded black must be at 45°.

(c) Towing with a sling type truck

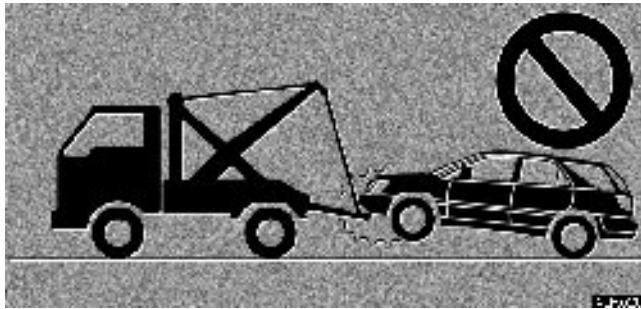

**NOTICE**  
*Do not tow with a sling type truck, either from the front or rear. This may cause body damage.*

(d) Emergency towing



## IN CASE OF AN EMERGENCY

---

**If towing is necessary, we recommend you to have it done by your Lexus dealer or a commercial tow truck service.**

**If towing service is not available in an emergency, your vehicle may be temporarily towed by a cable or chain secured to the emergency towing eyelet. Use extreme caution when towing the vehicle.**

A driver must be in the vehicle to steer it and operate the brakes.

Towing in this manner may be done only on hard-surfaced roads for a short distance and at low speeds. Also, the wheels, axles, drive train, steering and brakes must all be in good condition.



**CAUTION**

Use extreme caution when towing the vehicle. Avoid sudden starts or erratic driving maneuvers which would place excessive stress on the emergency towing eyelet and towing cable or chain. The eyelet and towing cable or chain may break and cause serious injury or damage.

**NOTICE**

- *Use only a cable or chain specifically intended for use in towing vehicles. Securely fasten the cable or chain to the towing eyelet provided.*
- *Never use the eyelets under the front bumper. If you use them for towing, it may damage the vehicle and cause an unexpected accident.*

Before towing, release the parking brake and put the transmission in "N". The ignition key must be in "ACC" (engine off) or "ON" (engine running).



**CAUTION**

If the engine is not running, the power assist for the brakes and steering will not work so steering and braking will be much harder than usual.

## IN CASE OF AN EMERGENCY

---

### Emergency towing eyelet precautions:

- Before emergency towing, check that the eyelet is not broken or damaged and that the installation bolts are not loose.
- Fasten the towing cable or chain securely to the eyelet.
- Do not jerk the eyelet. Apply steady and even force.
- To avoid damaging the eyelet, do not pull from the side or at a vertical angle. Always pull straight ahead.



### CAUTION

**If the emergency towing eyelet is used to get out when your vehicle becomes stuck in the mud, sand or other condition from which the vehicle cannot be driven out under its own power, make sure to observe the precautions mentioned below. Otherwise, excessive stress will be put on the eyelet and the towing cable or chain may break, causing serious injury or damage.**

- **If the towing vehicle can hardly move, do not forcibly continue the towing. Contact your Lexus dealer or a commercial tow truck service for assistance.**
- **Tow the vehicle as straight ahead as possible.**
- **Keep away from the vehicle during towing.**

**Tips for towing a stuck vehicle:**

**The following methods are effective to use when your vehicle is stuck in the mud, sand or other condition from which the vehicle cannot be driven out under its own power. Use extreme caution when towing the vehicle. In addition, keep away from the vehicles and towing cable or chain when towing.**

- Remove the sand and soil in the front and the back of the tires.
- Place stones or wood under the tires.

**IF YOU CANNOT SHIFT  
AUTOMATIC TRANSMISSION  
SELECTOR LEVER**



## IN CASE OF AN EMERGENCY

---



**If you cannot shift the selector lever out of "P" position to other positions even though the brake pedal is depressed, use the shift lock override button as follows:**

- 1** Turn the ignition key to "LOCK". Make sure the parking brake is applied.
- 2** Pry up the cover with a flat-bladed screwdriver or equivalent.



- 3 Push down the shift lock override button. You can shift out of "P" position only while pushing the button.
- 4 Shift into "N" position.  
Insert the cover. Start the engine. For your safety, keep the brake pedal depressed.

Be sure to have the system checked by your Lexus dealer as soon as possible.

## IF YOU LOSE YOUR KEYS OR LOCK YOURSELF OUT

**Many Lexus dealers can make a new key if you can give them the key number. Since your vehicle is equipped with the engine immobiliser system, the dealer will also need your master key.**

See the suggestion given in "Keys" on page 8.

If your keys are locked in the vehicle and you cannot get a duplicate, many Lexus dealers can still open the door for you, using their special tools. If you must break a window to get in, we suggest breaking the smallest side window because it is the least expensive to replace. Be extremely cautious to avoid cuts from the glass.

Even if you lose only one key, contact your Lexus dealer to make a new key. If you lose all your master keys, you cannot make new keys; the whole system must be replaced.



## *SECTION 5*

---

### **MAINTENANCE**

Maintenance requirements .....	380
General maintenance .....	382
Does your vehicle need repairing? .....	385

*For scheduled maintenance information, please refer to the separate "Owner's Manual Supplement/ Maintenance Schedule".*

## MAINTENANCE

---

### MAINTENANCE REQUIREMENTS

Your Lexus vehicle has been designed to have fewer maintenance requirements with longer service intervals to save both your time and money. However, each regular maintenance as well as day-to-day care is more important than ever before to ensure smooth, trouble-free, safe, and economical driving.

It is the owner's responsibility to make sure the specified maintenance, including general maintenance services, is performed. Note that both the new vehicle and emission control system warranties specify that proper maintenance and care must be performed. See the Owner's Guide, Owner's Manual Supplement or Warranty Booklet for complete warranty information.

### General maintenance

General maintenance items are those day-to-day care practices that are important to your vehicle for proper operation. It is the owner's responsibility to ensure that the general maintenance items are performed regularly.

These checks or inspections can be done either by yourself or your Lexus dealer.

### Scheduled maintenance

The scheduled maintenance items listed in the "Owner's Manual Supplement/Maintenance Schedule" are those required to be serviced at regular intervals.

For details of your maintenance schedule, read the separate "Owner's Manual Supplement/Maintenance Schedule".

**It is recommended that any replacement parts used for maintenance or for the repair of the emission control system be Lexus supplied.**

**The owner may elect to use non-Lexus supplied parts for replacement purposes without invalidating the emission control system warranty. However, use of replacement parts which are not of equivalent quality may impair the effectiveness of the emission control systems.**

**You may also elect to have maintenance, replacement, or repair of the emission control devices and system performed by any automotive repair establishment or individual without invalidating this warranty. See Owner's Guide, Owner's Manual Supplement or Warranty Booklet for complete warranty information.**

### **Where to go for service?**

Lexus technicians are well-trained specialists and are kept up to date with the latest service information through technical bulletins, service tips, and in-dealership training programs. They are well informed about the operation of all the systems on your vehicle.

You can be confident that your Lexus dealer's service department performs the best job to meet the maintenance requirements of your vehicle.

Your copy of the repair order is proof that all required maintenance has been performed for warranty coverage. And if any problems should arise with your vehicle while under warranty, your Lexus dealer will promptly take care of it. Again, be sure to keep a copy of the repair order for any service performed on your Lexus.

### **What about do-it-yourself maintenance?**

Many of the maintenance items are easy to do yourself, if you have a little mechanical ability and a few basic automotive tools. Simple instructions for how to perform them are presented in Section 6.

If you are a skilled do-it-yourself mechanic, the Lexus service manuals are recommended. Please be aware that do-it-yourself maintenance can affect your warranty coverage. See your Owner's Guide, Owner's Manual Supplement or Warranty Booklet for the details.

## MAINTENANCE

---

### GENERAL MAINTENANCE

Listed below are the general maintenance items that should be performed at the intervals specified. It is recommended that any problem you notice be brought to the attention of your Lexus dealer or qualified service shop for their advice.



#### CAUTION

**Make these checks only where adequate ventilation can be obtained if you run the engine.**

#### Vehicle exterior

**Items listed below should be performed from time to time, unless otherwise specified.**

##### Tire pressure

Check the pressure with a gauge every two weeks, or at least once a month and adjust as shown on the tire pressure label. See page 424 for additional information.

##### Tire surface

Check the tires carefully for cuts, damage or excessive wear. See page 426 for additional information.

##### Wheel nuts

When checking the tires, make sure to check the nuts for looseness. Tighten them if necessary.

#### Tire rotation

Rotate the tires every 12000 km (7500 miles). See page 425 for additional information.

#### Fluid leaks

Check underneath for leaking fuel, oil, water or other fluid after the vehicle has been parked for a while. If you smell fuel fumes or notice any leak, have the cause found and corrected immediately.

#### Doors and engine hood

Check that all doors and back door operate smoothly and all latches lock securely. Make sure the engine hood secondary latch secures the hood when the primary latch is released.

### **Vehicle interior**

**Items listed below should be checked regularly, e.g. while performing periodic services, cleaning the vehicle, etc.**

#### **Lights**

Make sure the headlight, stop lights, tail lights, turn signal lights, and other lights are working. Check headlight aim.

#### **Service reminder indicators and warning buzzers**

Check that all service reminder indicators and warning buzzers function properly.

#### **Steering wheel**

Check that it has the specified freeplay. Be alert for changes in steering condition, such as hard steering, excessive freeplay or strange noise.

#### **Seats**

Check that all front seat controls such as seat adjusters, seatback recliner, etc. operate smoothly. Check that the head restraints move up and down smoothly and that the locks hold securely in any latched position. For folding-down rear seatbacks, check that the latches lock securely.

#### **Seat belts**

Check that the seat belt system such as buckles, retractors and anchors operate properly and smoothly. Make sure the belt webbing is not cut, frayed, worn or damaged.

### **Accelerator pedal**

Check the pedal for smooth operation and uneven pedal effort or catching.

### **Brake pedal**

Check the pedal for smooth operation and the proper clearance and freeplay. Check the brake booster function.

### **Brakes**

At a safe place, check that the brakes do not pull to one side when applied.

### **Parking brake**

Check that the pedal has the proper travel and that, on a safe incline, your vehicle is held securely with only the parking brake applied.

### **Automatic transmission "Park" mechanism**

Check the lock release button of the selector lever for proper and smooth operation. On a safe incline, check that your vehicle is held securely with the selector lever in "P" position and all brakes released.



## MAINTENANCE

---

### **Engine compartment**

**Items listed below should be checked from time to time, e.g. each time when refueling.**

#### **Washer fluid**

Make sure there is sufficient fluid in the tank. See page 458 for additional information.

#### **Engine coolant level**

Make sure the coolant level is between the "FULL" and "LOW" lines on the see-through reservoir when the engine is cold. See page 411 for additional information.

#### **Battery**

Your Lexus has a maintenance free battery. You do not have to add distilled water. For longer life of the battery, however, see page 443 for additional information.

#### **Brake fluid level**

Make sure the brake fluid level is correct. See page 419 for additional information.

#### **Engine oil level**

Check the level on the dipstick with the engine turned off and the vehicle parked on a level spot. See page 407 for additional information.

### **Power steering fluid level**

Check the level through the reservoir. The level should be in the "HOT" or "COLD" range depending on the fluid temperature. See page 420 for additional information.

### **Exhaust system**

If you notice any change in the sound of the exhaust or smell exhaust fumes, have the cause located and corrected immediately. (See engine exhaust cautions in Section 3-1.)

## **DOES YOUR VEHICLE NEED REPAIRING?**

Be on the alert for changes in performance and sounds, and visual tip-offs that indicate service is needed. Some important clues are:

- Engine missing, stumbling, or pinging
- Appreciable loss of power
- Strange engine noises
- A fluid leak under the vehicle (However, water dripping from the air conditioning after use is normal.)
- Change in exhaust sound (This may indicate a dangerous carbon monoxide leak. Drive with the windows open and have the exhaust system checked immediately.)
- Flat-looking tires, excessive tire squeal when cornering, uneven tire wear
- Vehicle pulls to one side when driving straight on a level road
- Strange noises related to suspension movement
- Loss of brake effectiveness, spongy feeling brake pedal, pedal almost touches floors, vehicle pulls to one side when braking
- Engine coolant temperature continually higher than normal

If you notice any of these clues, take your vehicle to your Lexus dealer as soon as possible. It probably needs adjustment or repair.

## MAINTENANCE

---



### CAUTION

**Do not continue driving with the vehicle unchecked. It could result in serious vehicle damage and possibly personal injury.**

;

# *SECTION 6 - 1*

---

## **SERVICE PROCEDURES AND SPECIFICATIONS**

### **Introduction**

Vehicle identification .....	389
Engine compartment overview .....	390
Do-it-yourself service precautions .....	392
Parts and tools .....	394

## VEHICLE IDENTIFICATION

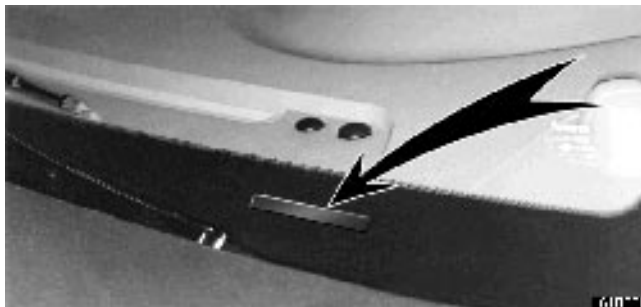

**The vehicle identification number (VIN) is the legal identifier for your vehicle. This number is on the left top of the instrument panel and can be seen through the windshield from outside.**

This is the primary identification number for your Lexus. It is used in registering the ownership of your vehicle.

## INTRODUCTION

---

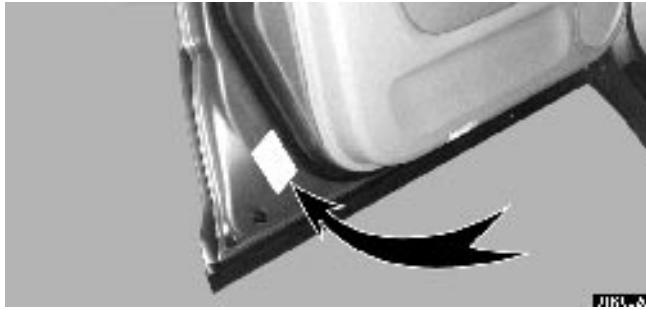

The vehicle identification number (VIN) is also on the Certification Label.



The engine number is stamped on the engine block as shown.

## ENGINE COMPARTMENT OVERVIEW

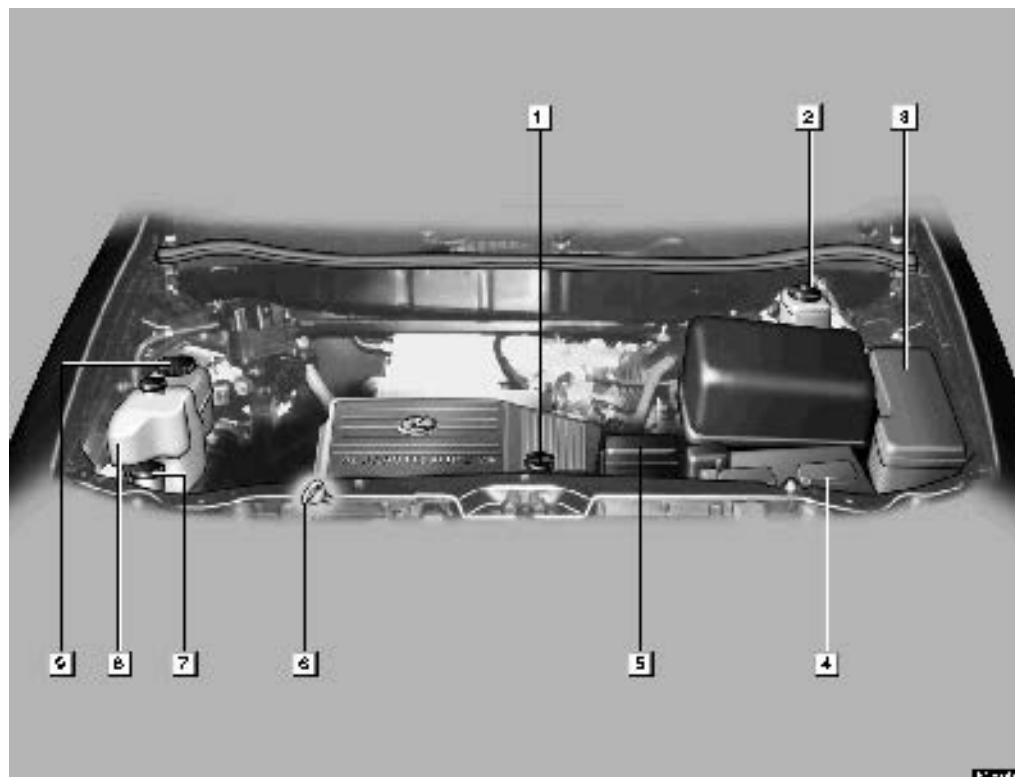

- 1 *Engine oil filler cap*
- 2 *Brake fluid reservoir*
- 3 *Fuse box*
- 4 *Battery*
- 5 *Fuse box*
- 6 *Engine oil level dipstick*
- 7 *Washer fluid tank*
- 8 *Engine coolant reservoir*
- 9 *Power steering fluid reservoir*



## INTRODUCTION

---

### **DO-IT-YOURSELF SERVICE PRECAUTIONS**

**If you perform maintenance yourself, be sure to follow the correct procedure given in this Section.**

You should be aware that improper or incomplete servicing may result in operating problems.

Performing do-it-yourself maintenance during the warranty period may affect your warranty coverage. Read the separate Lexus Warranty statement for details and suggestions.

This Section gives instructions only for those items that are relatively easy for an owner to perform. As explained in Section 5, there are still a number of items that must be performed by a qualified technician with special tools.

For information on tools and parts for do-it-yourself maintenance, see "Parts and tools".

Utmost care should be taken when working on your vehicle to prevent accidental injury. Here are a few precautions that you should be especially careful to observe:



### CAUTION

- When the engine is running, keep hands, clothing, and tools away from the moving fan and engine drive belt. (Removing rings, watches, and ties is advisable.)
- Right after driving, the engine compartment – the engine, radiator, exhaust manifold and power steering fluid reservoir, etc. – will be hot. So be careful not to touch them. Oil and other fluids may also be hot.
- Do not smoke, cause sparks or allow open flames near fuel or the battery. Their fumes are flammable.
- Be extremely cautious when working on the battery. It contains poisonous and corrosive sulfuric acid.
- Do not get under your vehicle with just the body jack supporting it. Always use automotive jack stands or other solid supports.
- Use eye protection whenever you work on or under your vehicle where you may be exposed to flying or falling material, fluid spray, etc.

## INTRODUCTION

---

### NOTICE

- *Remember that battery and ignition cables carry high currents or voltages. Be careful of accidentally causing a short circuit.*
- *Before closing the engine hood, check to see that you have not forgotten any tools, rags, etc.*
- *Do not drive with the air cleaner removed, or excessive engine wear could result. Also backfiring could cause a fire in the engine compartment.*
- *Do not overfill automatic transmission fluid, or the transmission could be damaged.*
- *Be careful not to scratch the glass surface with the wiper frame.*

## PARTS AND TOOLS

Here is a list of parts and tools you will need to perform do-it-yourself maintenance. Remember all Lexus parts are designed in metric sizes, so your tools must be metric.

### Checking the engine oil level

#### Parts (if level is low):

- Use API grade SH, "Energy-Conserving II" or SJ, "Energy-Conserving" multigrade engine oil or ILSAC multigrade engine oil. For recommended oil viscosity, see page 410.

#### Tools:

- Rag or paper towel
- Funnel (only for adding oil)

### Checking the engine coolant level

#### Parts (if level is low):

- "Toyota Long Life Coolant" or equivalent  
See "Checking the engine coolant level" on page 411 for instructions.
- Demineralized or distilled water

#### Tools:

- Funnel (only for adding coolant)

### Checking brake fluid

**Parts (if level is low):**

- FMVSS No. 116 DOT 3 or SAE J1703 brake fluid

**Tools:**

- Funnel (only for adding fluid)

### Checking power steering fluid

**Parts (if level is low):**

- Automatic transmission fluid DEXRON<sup>®</sup> II or III

**Tools:**

- Rag or paper towel
- Funnel (only for adding fluid)

### Checking battery condition

**Non-maintenance batteries**

**Tools:**

- Warm water
- Baking soda
- Grease
- Conventional wrench (for terminal clamp bolts)

**Maintenance type batteries**

**Parts (if level is low):**

- Distilled water

**Tools:**

- Warm water
- Baking soda
- Grease
- Conventional wrench (for terminal clamp bolts)
- Coin (for vent plugs)
- Funnel (only for adding distilled water)

## **INTRODUCTION**

---

### **Checking and replacing the blade type fuses**

#### **Parts (if replacement is necessary):**

- Fuse with same amperage rating as original

### **Checking the cartridge type fuses**

#### **Parts (if replacement is necessary):**

- Genuine Lexus fuse or equivalent with same amperage rating as original

### **Adding washer fluid**

#### **Parts:**

- Water
- Washer fluid containing antifreeze (for winter use)

#### **Tools:**

- Funnel

!

## *SECTION 6 - 2*

---

### **SERVICE PROCEDURES AND SPECIFICATIONS**

#### **Engine**

Specifications .....	399
Fuel .....	402
Facts about engine oil consumption .....	404
Used engine oil .....	406
Checking the engine oil level .....	407
Checking the engine coolant level .....	411
Spark plugs .....	414

---

**SPECIFICATIONS****– GENERAL**

Model	1MZ – FE
Type	6 cylinder V type, 4 cycle, gasoline
Bore and stroke	87.5 X 83 mm (3.44 X 3.27 in.)
Displacement	2995 cm <sup>3</sup> (182.7 cu.in.)
Valve clearance (engine cold)	
Intake	0.15 – 0.25 mm (0.006 – 0.010 in.)
Exhaust	0.25 – 0.35 mm (0.010 – 0.014 in.)
Drive belt tension (with Borroughs drive belt tension gauge No. BT-33-73F)	115 ± 20 lb.

**– LUBRICATION SYSTEM**



## ENGINE

---

Oil capacity Drain and refill with filter without filter	4.7 L (5.0 qt., 4.1 imp.qt.) 4.5 L (4.8 qt., 4.0 imp.qt.)
Oil grade	API SH, "Energy-Conserving II" or SJ, "Energy-Conserving" multigrade engine oil or ILSAC multigrade engine oil
Recommended oil viscosity (SAE):	

### - COOLING SYSTEM

Capacity Coolant type	9.0 L (9.5 qt., 7.9 imp.qt.) "Toyota Long Life Coolant" or equivalent With ethylene-glycol type coolant for a proper corrosion protection of aluminum components Do not use alcohol type antifreeze or plain water alone.
--------------------------	---

### - FUEL

Fuel type Octane Rating	Only UNLEADED 87 (Research Octane Number 91) or higher
----------------------------	---

### - IGNITION SYSTEM

**ENGINE**

Spark plug	– Make	DENSO NGK	SK20R11 IFR6A11 1.1 mm (0.043 in.)
	– Gap		

**– ELECTRICAL SYSTEM**

Battery	– Maintenance type battery		
	Specific gravity reading at 20°C (68°F):		1.260 Fully charged 1.160 Half charged 1.060 Discharged
	Charging rates	Quick charge Slow charge	15A max. 5A max.
	– Non-maintenance battery		
	Open voltage at 20°C (68°F):		12.7V Fully charged 12.3V Half charged 11.9V Discharged [Voltage that is checked 20 minutes after the key is removed with all the lights turned off]
	Charging rates		5A max.

## ENGINE

---

### FUEL

#### Fuel type

**Your vehicle must use only unleaded gasoline.**

To help prevent gas station mixups, your Lexus has a smaller fuel tank opening. The special nozzle on pumps with unleaded fuel will fit it, but the larger nozzle on pumps with leaded gas will not.

At a minimum, the gasoline you use should meet the specifications of ASTM D4814 in the U.S.A. and CGSB 3.5-M93 in Canada.

#### **NOTICE**

*Do not use leaded gasoline. Use of leaded gasoline will cause the three-way catalytic converter/warm up three-way catalytic converter to lose its effectiveness and the emission control system to function improperly. Also, this can increase maintenance costs.*

#### Octane rating

**Select Octane Rating 87 (Research Octane Number 91) or higher. For improved vehicle performance, the use of premium unleaded gasoline with an Octane Rating of 91 (Research Octane Number 96) or higher is recommended.**

Use of unleaded fuel with an Octane Rating or Research Octane Number lower than stated above will cause persistent heavy knocking. If it is severe, this will lead to engine damage.

**If your engine knocks ...**

If you detect heavy knocking even when using the recommended fuel, or if you hear steady knocking while holding a steady speed on level roads, consult your Lexus dealer.

However, now and then, you may notice light knocking for a short time while accelerating or driving up hills. This is no cause for concern.

**Gasolines containing detergent additives**

**Lexus recommends use of gasolines that contain detergent additives to avoid build-up of engine deposits.**

For further details, ask your Lexus dealer or a local gasoline retailer.

**Improved gasolines**

**The American Automobile Manufacturers Association (AAMA) has developed a specification of improved gasolines. The AAMA specification offers optimal fuel information for better vehicle performance and better protection of your engine.**

Lexus recommends the use of gasolines that meet the AAMA specification, if available, for improved drivability and emission control system.

**Gasolines containing MTBE**

**Gasolines that contain MTBE (Methyl Tertiary-Butyl Ether) are available in the market. If you use a gasoline mixed with MTBE, make certain that it does not contain more than 15% of MTBE.**

**Gasolines containing MMT**

**Some gasolines contain an octane-enhancing additive called MMT (methylcyclopentadienyl manganese tricarbonyl).**

Lexus does not recommend the use of gasolines that contain MMT. If fuels containing MMT are used, your emission control system may be adversely affected. The Malfunction Indicator Lamp on the instrument cluster may come on. If this happens, contact your Lexus dealer for service.

**Gasolines containing alcohol**

**Gasohol is a mixture of gasoline and ethanol. If you use gasohol in your Lexus, be sure that it is unleaded, has an octane rating no lower than 87 and does not contain more than 10% ethanol. Lexus does not recommend the use of gasolines containing methanol.**

If you use gasoline containing methanol, use only gasoline meeting the requirements above and also containing less than 5% methanol with cosolvents and corrosion inhibitors for methanol.

## ENGINE

---

### Gasolines quality

In a very few cases, you may experience driveability problems caused by the particular gasoline that you are using. If you continue to have unacceptable driveability, try changing gasoline brands. If that does not rectify your problem, then consult your Lexus dealer.

#### **NOTICE**

- *Do not use gasohol other than stated above. It will cause fuel system damage or vehicle performance problems.*
- *If drivability problems are encountered (poor hot starting, vaporizing, engine knock, etc.), discontinue its use.*
- *Take care not to spill gasohol during refueling. Gasohol may cause paint damage.*

### Fuel tank capacity

65 L (17.2 gal., 14.3 imp.gal.)

## FACTS ABOUT ENGINE OIL CONSUMPTION

### Functions of engine oil

Engine oil has the primary function of lubricating and cooling the inside of the engine, and plays a major role in maintaining the engine in proper working order.

### Engine oil consumption

**It is normal that an engine should consume some engine oil during normal engine operation. The causes of oil consumption in a normal engine are as follows.**

- Oil is used to lubricate pistons, piston rings and cylinders. A thin film of oil is left on the cylinder wall when a piston moves downwards in the cylinder. High negative pressure generated when the vehicle is decelerating sucks some of this oil into the combustion chamber. This oil as well as some part of the oil film left on the cylinder wall is burned by the high temperature combustion gases during the combustion process.
- Oil is also used to lubricate the stems of the intake valves. Some of this oil is sucked into the combustion chamber together with the intake air and is burned along with the fuel. High temperature exhaust gases also burn the oil used to lubricate the exhaust valve stems.

**The amount of engine oil consumed depends on the viscosity of the oil, the quality of the oil and the way the vehicle is driven.**

More oil is consumed under driving conditions such as high speeds and frequent acceleration and deceleration.

A new engine consumes more oil, since its pistons, piston rings and cylinder walls have not become conditioned.

**When judging the amount of oil consumption, keep in mind that the oil may have become diluted, making it difficult to judge the true level accurately.**

For example, if a vehicle is used for repeated short trips and consumes a normal amount of oil, the dipstick may not show any drop in the oil level at all, even after 1000 km (600 miles) or more. This is because the oil is gradually becoming diluted with fuel or moisture, making it appear that the oil level has not changed.

The diluting ingredients evaporate out when the vehicle is then driven at high speeds, as on an expressway, making it appear that oil is excessively consumed after driving at high speeds.

### **Importance of engine oil level check**

One of the most important points in proper vehicle maintenance is to keep the engine oil at the optimum level so that oil function will not be impaired. Therefore, it is essential that the oil level be checked regularly. Lexus recommends that the oil level be checked every time you refuel the vehicle.

#### ***NOTICE***

***Failure to check the oil level regularly could lead to serious engine trouble due to insufficient oil.***

For detailed information on oil level check, see "Checking the engine oil level" on page 407.

## ENGINE

---

### USED ENGINE OIL



#### CAUTION

- **Used engine oil contains potentially harmful contaminants which may cause skin disorders such as inflammation or skin cancer, so care should be taken to avoid prolonged and repeated contact with it. To remove used engine oil from your skin, wash thoroughly with soap and water.**
- **Do not leave used oil within the reach of children.**
- **Dispose of used oil and used oil filters only in a safe and acceptable manner. Do not dispose of used oil and used oil filters in household trash, in sewers or onto the ground. Call your Lexus dealer or a service station for information concerning recycling or disposal.**

## CHECKING THE ENGINE OIL LEVEL



**With the engine at operating temperature and turned off, check the oil level on the dipstick.**

1. To get a true reading, the vehicle should be on a level spot. After turning off the engine, wait a few minutes for the oil to drain back into the bottom of the engine.
2. Pull out the dipstick, and wipe it clean with a rag.
3. Reinsert the dipstick and push it in as far as it will go, or the reading will not be correct.



## ENGINE

---

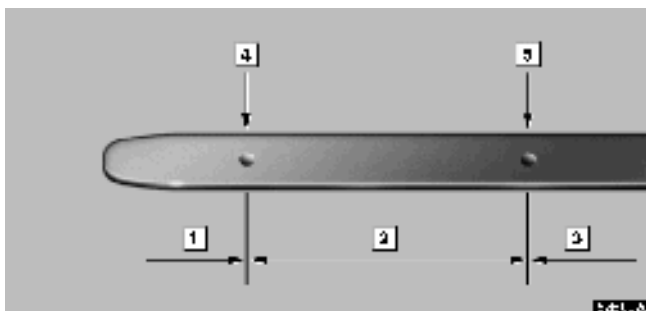

► **1** Add oil **2** O.K. **3** Too full

4. Pull the dipstick out and look at the oil level on the end.  
If it is between the full line ( **5** ) and the low line ( **6** ), it is O.K.



**If the oil level is below or only slightly above the low line, add engine oil of the same type as already in the engine.**

Remove the oil filler cap and add engine oil a little at a time, checking the dipstick. The approximate quantity of oil needed to fill between the low line and the full line on the dipstick is indicated below for reference.

When the level reaches within the correct range, return the filler cap and turn the cap clockwise until you hear a click.

Oil quantity. L (qt., Imp. qt.)                      1.8 (1.9, 1.6)

***NOTICE***

***Avoid overfilling, or the engine could be damaged. Check the oil level on the dipstick once again after adding the oil.***

## ENGINE

---

### Engine oil selection

Use API SH, "Energy-Conserving II" or SJ, "Energy-Conserving" multigrade engine oil or ILSAC multigrade engine oil.

Recommended viscosity (SAE):

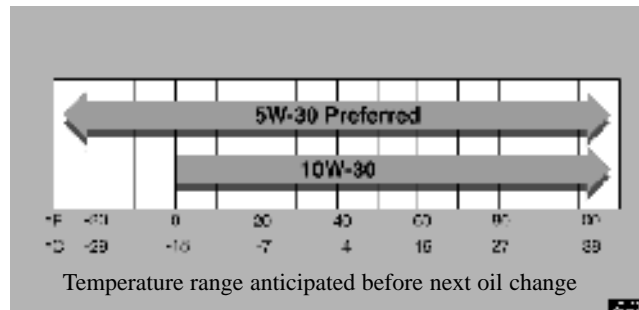

**SAE 5W-30 is the best choice for your vehicle, for good fuel economy, and good starting in cold weather.**

**If you use SAE 10W-30 engine oil in extremely low temperatures, the engine may become difficult to start, so SAE 5W-30 engine oil is recommended.**

### Oil identification marks



▶ *API Service Symbol Mark*

▶ *ILSAC Certification Mark*

Either or both API registered marks are added to some oil containers to help you select the oil you should use.

- The API Service Symbol is located anywhere on the outside of the container.

The top portion of the label shows the oil quality by API (American Petroleum Institute) designation such as SJ. The center portion of the label shows the SAE viscosity grade such as SAE 5W-30. "Energy-Conserving", shown in the lower portion, indicates that the oil has fuel-saving capabilities.

- The ILSAC (International Lubricant Standardization and Approval Committee) Certification Mark is displayed on the front of the container.

## CHECKING THE ENGINE COOLANT LEVEL

## ENGINE

---

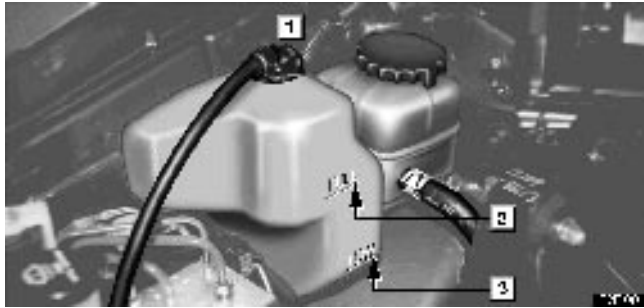

► **1** Reservoir cap **2** Upper line **3** Lower line

**Look at the see-through coolant reservoir when the engine is cold. The coolant level is satisfactory if it is between the "FULL" and "LOW" lines on the reservoir. If the level is low, add ethylene-glycol type coolant for a proper corrosion protection of aluminum components.**

The coolant level in the reservoir will vary with engine temperature. However, if the level is on or below the "LOW" line, add coolant. Bring the level up to the "FULL" line.

Always use ethylene-glycol type coolant for a proper corrosion protection of aluminum components. See information in the next column.

If the coolant level drops within a short time after replenishing, there may be a leak in the system. Visually check the radiator, hoses, engine coolant filler cap, radiator cap and drain cock and water pump.

If you can find no leak, have your Lexus dealer test the radiator cap pressure and check for leaks in the cooling system.

**CAUTION**

**To prevent burning yourself, do not remove the radiator cap when the engine is hot.**

**Coolant type selection**

Use of improper coolants may damage your engine cooling system. Your coolant must contain ethylene-glycol type coolant for a proper corrosion protection of your engine that contains aluminum components. Use "Toyota Long Life Coolant" or equivalent.

In addition to preventing freezing and subsequent damage to the engine, this type of coolant will also prevent corrosion. Further supplemental inhibitors or additives are neither needed nor recommended.

Read the coolant container for information on freeze protection. Follow the manufacturer's directions for how much to mix with plain water (preferably demineralized water or distilled water). The total capacity of the cooling system is given on page 400.

We recommend to use 50% solution for your Lexus, to provide protection down to about  $-35^{\circ}\text{C}$  ( $-31^{\circ}\text{F}$ ). When it is extremely cold, to provide protection down to about  $-50^{\circ}\text{C}$  ( $-58^{\circ}\text{F}$ ), 60% solution is recommended. Do not use more than 70% solution for better coolant performance.

***NOTICE***

***Do not use alcohol type antifreeze or plain water alone.***

## ENGINE

---

### SPARK PLUGS



Your engine is fitted with iridium-tipped spark plugs.

#### **NOTICE**

*Use only iridium-tipped spark plugs for your engine performance and smooth drivability.*

2



## *SECTION 6 – 3*

---

### **SERVICE PROCEDURES AND SPECIFICATIONS**

#### **Chassis**

Specifications .....	417
Checking brake fluid .....	419
Checking power steering fluid .....	420
Checking tire pressure .....	424
Rotating tires .....	425
Checking and replacing tires .....	426
Installing snow tires and chains .....	429
Replacing wheels .....	432
Aluminum wheel precautions .....	432
Suspension and chassis .....	433

## SPECIFICATIONS

### – TRANSFER

Oil capacity	0.9 L (1.0 qt., 0.8 Imp.qt.)
Oil type	Hypoid gear oil API GL-5
Recommended oil viscosity	Above -18°C (0°F) SAE 90 Below -18°C (0°F) SAE 80W or 80W-90

### – AUTOMATIC TRANSAXLE

Fluid capacity	3.1 L (3.3 qt., 2.7 Imp.qt.) 3.9 L (4.1 qt., 3.4 Imp.qt.)
Drain and refill	
Two-wheel drive models Four-wheel drive models	
Fluid type	<b>Automatic transmission fluid T-IV</b> or equivalent

### – DIFFERENTIAL

Oil capacity	0.9 L (1.0 qt., 0.8 Imp. qt.)
Oil type	Hypoid gear oil API GL-5
Recommended oil viscosity	Above -18°C (0°F) SAE 90 Below -18°C (0°F) SAE 80W or 80W-90

## CHASSIS

---

### – BRAKES

Pedal clearance	122 mm (5.0 in.) Min. * <sup>1</sup>
Pedal freeplay	1 – 6 mm (0.04 – 0.24 in.)
Brake pad wear limit	1.0 mm (0.04 in.)
Parking brake lining wear limit	1.0 mm (0.04 in.)
Parking brake adjustment	5 – 7 clicks * <sup>2</sup>
Fluid type	SAE J1703 or FMVSS No. 116 DOT 3

\*<sup>1</sup>: Minimum pedal clearance when depressed with the pressure of 490 N (50 kgf, 110 lbf.) with the engine running

\*<sup>2</sup>: Parking brake adjustment when depressed with the pressure of 294 N (30 kgf, 66 lbf.)

### – STEERING

Wheel freeplay	Less than 30 mm (1.2 in.)
Power steering fluid type	Automatic transmission fluid DEXRON® II or III

### – TIRES AND WHEELS

<p>Tire size</p> <p>Recommended cold tire inflation pressure</p> <p>    Vehicle loaded up to vehicle capacity weight</p> <p>    Spare tire</p> <p>    Trailer towing (conventional and snow tires)</p> <p>Wheel size</p> <p>Wheel nut torque</p>	<p>P225/70R16 101S</p> <p>210 kPa (2.1 kgf/cm<sup>2</sup> or bar, 30 psi) (Both front and rear)</p> <p>210 kPa (2.1 kgf/cm<sup>2</sup> or bar, 30 psi)</p> <p>210 kPa (2.1 kgf/cm<sup>2</sup> or bar, 30 psi) (Both front and rear)</p> <p>For sustained high speeds above 160 km/h (100 mph), in countries where such speeds are permitted by law, add 30 kPa (0.3 kgf/cm<sup>2</sup> or bar, 5 psi) to the front tires and rear tires, but never exceed the maximum cold tire pressure molded on the tire sidewall.</p> <p>16 x 6.5 JJ</p> <p>103 N·m (10.5 kgf·m, 76 ft·lbf.)</p>
---	--

### CHECKING BRAKE FLUID



## CHASSIS

---

**To check the fluid level, simply look at the see-through reservoir. The level should be between the "MAX" and "MIN" lines on the tank.**

It is normal for the brake fluid level to go down slightly as the brake pads wear. So be sure to keep the reservoir filled.

If the reservoir needs frequent refilling, it may indicate a serious mechanical problem.

**If the level is low, add FMVSS No.116 DOT 3 or SAE J1703 brake fluid to the brake reservoir.**

Remove and replace the reservoir cover by hand. Add brake fluid up to the "MAX" line.

Use only newly opened brake fluid. Once opened, brake fluid absorbs moisture from the air, and excess moisture can cause a dangerous loss of braking efficiency.



### CAUTION

**Take care when filling the reservoir because brake fluid can harm your hands or eyes and damage painted surfaces. If fluid gets in your hands or eyes, flush them with clean water.**

### NOTICE

*If you spill some of the fluid, be sure to wipe it off to prevent it from damaging the parts or paintwork.*

## CHECKING POWER STEERING FLUID



**Check the fluid level through the reservoir. If necessary, add automatic transmission fluid DEXRON® II or III.**

If the vehicle has been driven around 80 km/h (50 mph) for 20 minutes (a little more in frigid temperatures), the fluid is hot (60°C – 80°C or 140°F – 175°F). You may also check the level when the fluid is cold (about room temperature, 10°C – 30°C or 50°F – 85°F) if the engine has not been run for about five hours.

## CHASSIS

---

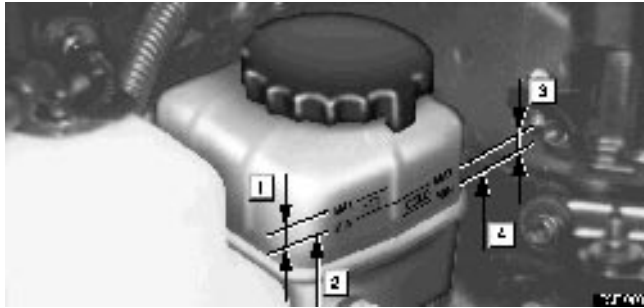

- **1** *If hot O.K.* **2** *If hot add* **3** *If cold O.K.*  
**4** *If cold add*

Clean all dirt off the reservoir and look at the fluid level. If the fluid is cold, the level should be in the "COLD" range. Similarly, if it is hot, the fluid level should be in the "HOT" range. If the level is at the low side of the appropriate range, add automatic transmission fluid DEXRON<sup>®</sup> II or III to bring the level within the range.

To remove the filler cap, turn it counterclockwise and lift up. To reinstall it, turn it clockwise. After replacing the filler cap, visually check the steering box case, vane pump and hose connections for leaks or damage.



### CAUTION

**The reservoir may be hot so be careful not to burn yourself.**

***NOTICE***

*Avoid overfilling, or the power steering could be damaged.*



### CHECKING TIRE PRESSURE



**The recommended cold tire pressures, tire size and the vehicle capacity weight are given on the label.**

You should check the tire pressures every two weeks, or at least once a month. And don't forget the spare! The air pressure for the spare tire should be 210 kPa (2.1 kgf/cm<sup>2</sup> or bar, 30 psi). Incorrect tire pressure can reduce tire life and make your vehicle less safe to drive.

Low tire pressure results in excessive wear, poor handling, reduced fuel economy, and the possibility of blowouts from overheated tires. Also, low tire pressure can cause poor sealing of the tire bead. If the tire pressure is excessively low, there is the possibility of wheel deformation and/or tire separation. So keep your tire pressures at the proper level. If a tire needs frequent refilling, have it checked by your Lexus dealer.

High tire pressure produces a harsh ride, handling problems, excessive wear at the center of the tire tread, and a greater possibility of tire damage from road hazards.

The following instructions for checking tire pressure should be observed:

- **The pressure should be checked only when the tires are cold.** If your vehicle has been parked for at least 3 hours and has not been driven for more than 1.5 km or 1 mile

since, you will get an accurate cold tire pressure reading.

- **Always use a tire pressure gauge.** The appearance of the tire can be misleading. Besides, tire pressures that are even just a few pounds off can degrade handling and ride.
- **Do not bleed or reduce tire pressure after driving.** It is normal for the tire pressure to be higher after driving.
- **Never exceed the vehicle capacity weight.** The passengers and luggage weight should be located so that the vehicle is balanced.
- **Be sure to reinstall the tire valve caps.** Without the valve caps, dirt or moisture could get into the valve core and cause air leakage. If the caps have been lost, have new ones put on as soon as possible.

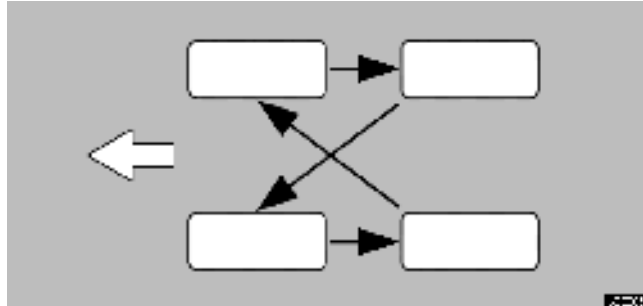

## ROTATING TIRES

## CHASSIS

---

**To equalize tire wear and help extend tire life, Lexus recommends that you rotate your tires approximately every 12000 km (7500 miles). However, the most appropriate timing for tire rotation may vary according to your driving habits and road surface conditions.**

The wheel assemblies must be rotated as illustrated above.

When rotating tires, check for uneven wear and damage. Abnormal wear is usually caused by incorrect tire pressure, improper wheel alignment, out-of-balance wheels, or severe braking.

Before storing radial, snow or studded tires, mark the direction of rotation and be sure to install them in the same direction when using them again. Tires should be stored in a cool dry place.

## CHECKING AND REPLACING TIRES

### When to replace your tires

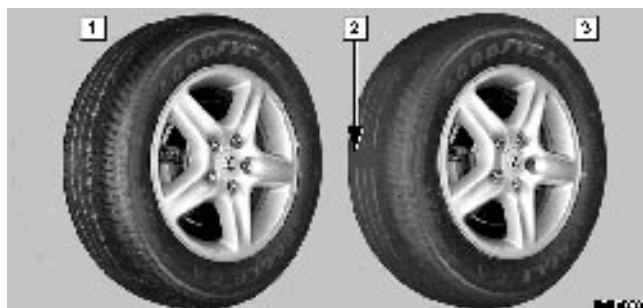

► **1** New tread **2** Tread wear indicator **3** Worn tread

**Replace the tires when the tread wear indicators show. The location of the tread wear indicators is shown by the marks such as "TWI" or "Δ" marks molded on the sidewall of each tire.**

The tires on your Lexus have built-in tread wear indicators to help you know when the tires need replacement. When the tread depth wears to 1.6 mm (0.06 in.) or less, the indicators will appear. If you can see the indicators in two or more adjacent grooves, the tire should be replaced.

**The effectiveness of snow tires is lost if the tread wears down below 4 mm (0.16 in.).**

**If you have tire damage such as cuts, splits, cracks deep enough to expose the fabric, or bulges indicating internal damage, the tire should be replaced.**

If a tire often goes flat or cannot be properly repaired due to the size or location of a cut or other damage, it should be replaced. If you are not sure, consult with your Lexus dealer.

If an air loss occurs while driving, do not continue driving with a deflated tire. Driving even a short distance can damage a tire beyond repair.

**Any tires which are over 6 years old must be checked by a qualified technician even if damage is not obvious.**

Tires deteriorate with age even if they have never or seldom been used.

This also applies to the spare tire and tires stored for future use.

## CHASSIS

---

### **Uniform tire quality grading**

**This information has been prepared in accordance with regulations issued by the National Highway Traffic Safety Administration of the U.S. Department of Transportation. It provides the purchasers and/or prospective purchasers of Lexus vehicles with information on uniform tire quality grading.**

**Your Lexus dealer will help answer any questions you may have as you read this information.**

**DOT quality grades – All passenger vehicle tires must conform to Federal Safety Requirements in addition to these grades. These quality grades are molded on the sidewall.**

**Treadwear** – The treadwear grade is a comparative rating based on the wear rate of the tire when tested under controlled conditions on a specified government test course. For example, a tire graded 150 would wear one and a half (1 – 1/2) times as well on the government course as a tire graded 100. The relative performance of tires depends upon the actual conditions of their use, however, and may depart significantly from the norm due to variations in driving habits, service practices and differences in road characteristics and climate.

**Traction A, B, C** – The traction grades, from highest to lowest, are A, B and C, and they represent the tire's ability to stop on wet pavement as measured under controlled conditions on specified government test surfaces of asphalt and concrete. A tire marked C may have poor traction performance.

Warning: The traction grade assigned to this tire is based on braking (straight ahead) traction tests and does not include cornering (turning) traction.

**Temperature A, B, C** – The temperature grades are A (the highest), B, and C, representing the tire's resistance to the generation of heat and its ability to dissipate heat when tested under controlled conditions on a specified indoor laboratory test wheel. Sustained high temperature can cause the material of the tire to degenerate and reduce tire life, and excessive temperature can lead to sudden tire failure. The grade C corresponds to a level of performance which all passenger car tires must meet under the Federal Motor Vehicle Safety Standard No. 109. Grades B and A represent higher levels of performance on the laboratory test wheel than the minimum required by law.

Warning: The temperature grade of this tire established for a tire that is properly inflated and not overloaded. Excessive speed, underinflation, or excessive loading, either separately or in combination, can cause heat buildup and possible tire failure.

### **Tire selection**

**When replacing a tire, use only the same size and construction as originally installed and with the same or greater load capacity.**

Using any other size or type of tire may seriously affect handling, ride, speedometer/odometer calibration, ground clearance, and clearance between the body and tires or snow chains.

**Do not mix radial, belted, or conventional tires on your vehicle.**

**Do not use tires or wheels other than the manufacturer's recommended size.**

It can cause dangerous handling characteristics, resulting in loss of control. If you need to change from conventional tires to radial tires or vice versa, replace them as a set.

## **INSTALLING SNOW TIRES AND CHAINS**

### **When to use snow tires or chains**

**Snow tires or chains are recommended when driving on snow or ice.**

On wet or dry roads, conventional or radial tires provide better traction than snow or studded tires.

### **Snow tire selection**

**If you need snow tires, select the same size, construction and load capacity as the original tires on your Lexus.**

Do not use tires other than stated above. Since your vehicle has radial tires as original equipment, make sure your snow tires also have radial construction. Do not install studded tires without first checking local regulations for possible restrictions.

### **Snow tire installation**

**Snow tires should be installed on all wheels.**

Installing snow tires on the front wheels only can lead to an excessive difference in road grip capability between the front and rear tires which could cause loss of vehicle control.

## CHASSIS

---



### CAUTION

- Snow tires should be inflated to the same pressure as the original tires.
- Never drive over 120 km/h (75 mph) with any type of snow tires.

### Tire chain selection

Regulations regarding the use of tire chains vary according to location or type of road. Always check the local regulations before installing chains.

Use only genuine Lexus tire chains or equivalent for RX300.  
Part No. 08329-48802

### NOTICE

*If the wrong combination of tire and chain is used, the chains could damage the vehicle body.*

### Chain installation

Install the chains on the front tires as tightly as possible. Do not use tire chains on the rear tires. Retighten chains after driving 0.5 – 1.0 km (1/4 – 1/2 mile).

When installing chains on your tires, carefully follow the instructions of the chain manufacturer.



**CAUTION**

- Do not exceed 50 km/h (30 mph) or the chain manufacturer's recommended speed limit, whichever is lower.
- Drive carefully avoiding bumps, holes, and sharp turns, which may cause the vehicle to bounce.
- Avoid sharp turns or locked-wheel braking, as use of chains may adversely affect vehicle handling.



## CHASSIS

---

### REPLACING WHEELS

#### When to replace your wheels

**If you have wheel damage such as bending, cracks or heavy corrosion, the wheel should be replaced.**

If you fail to replace damaged wheels, a tire may slip off a wheel or they may cause loss of handling control.

Replacement with used wheels is not recommended as they may have been subjected to rough treatment or high mileage and could fail without warning. Also, bent wheels which have been straightened may have hidden structural damage and therefore should not be used. Never use an inner tube in a leaking wheel which is designed for a tubeless tire.

#### Wheel selection

**When replacing wheels, care should be taken to ensure that they are equivalent to those removed in load capacity, diameter, rim width, and offset.**

Correct replacement wheels are available at your Lexus dealer.

A wheel of a different size or type may adversely affect handling, wheel and bearing life, brake cooling, speedometer/odometer calibration, stopping ability, headlight aim, bumper height, vehicle ground clearance, and tire or snow chain clearance to the body and chassis.

### ALUMINUM WHEEL PRECAUTIONS

- After driving your vehicle the first 1600 km (1000 miles), check that the wheel nuts are tight.
- If you have rotated, repaired, or changed your tires, check that the wheel nuts are still tight after driving 1600 km (1000 miles).
- When using tire chains, be careful not to damage the aluminum wheels.
- Use only the Lexus wheel nuts and wrench designed for your aluminum wheels.
- When balancing your wheels, use only Lexus balance weights or equivalent and a plastic or rubber hammer.
- As with any wheel, periodically check your aluminum wheels for damage. If damaged, replace immediately.

## SUSPENSION AND CHASSIS



### CAUTION

Do not modify the suspension/chassis with lift kits, spacers, springs, etc. It can cause dangerous handling characteristics, resulting in loss of control.

## *SECTION 6 - 4*

---

### **SERVICE PROCEDURES AND SPECIFICATIONS**

#### **Electrical components**

Specifications .....	435
Checking battery condition .....	443
Battery recharging precautions .....	449
Checking and replacing the blade type fuses .....	450
Checking the cartridge type fuses .....	455
Adding washer fluid .....	458
Replacing light bulbs .....	458

## SPECIFICATIONS

– FUSE LOCATIONS



## ELECTRICAL COMPONENTS

---

- ▶ 

1
---

*Engine compartment*
- |   |
|---|
| 2 |
|---|

*Engine compartment*
- |   |
|---|
| 3 |
|---|

*Driver's side instrument panel*

– FUSES

## ELECTRICAL COMPONENTS

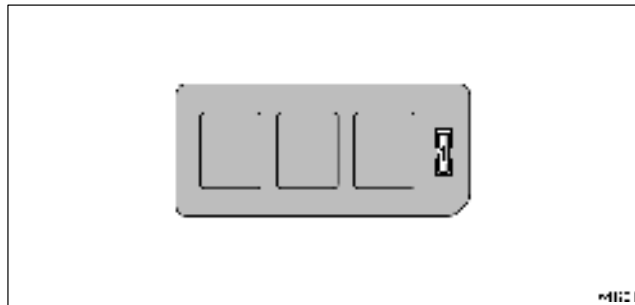

1 Engine compartment

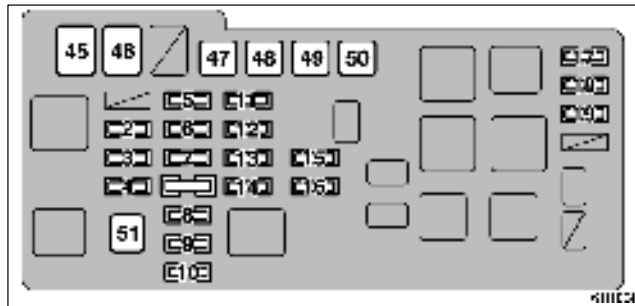

2 Engine compartment

## ELECTRICAL COMPONENTS

---



3 *Driver's side instrument panel*

## ELECTRICAL COMPONENTS

No.	FUSE	AMPERE	CIRCUIT
1	<b>DRL</b>	7.5	Daytime Running Light System
2	<b>H-LP R LWR</b>	15	Right-hand headlight (Low beam)
3	<b>H-LP L LWR</b>	15	Left-hand headlight (Low beam)
4	<b>HAZARD</b>	15	Emergency flashers, Turn signal lights
5	<b>AM2</b>	20	Starting system
6	<b>TEL</b>	15	Telephone
7	<b>FL DOOR</b>	20	Power door lock system
8	<b>SPARE</b>	7.5	Spare fuse
9	<b>SPARE</b>	15	Spare fuse
10	<b>SPARE</b>	25	Spare fuse
11	<b>ALT-S</b>	7.5	Charging system
12	<b>HORN</b>	10	Theft deterrent system, Horn
13	<b>EFI</b>	20	Multiport fuel injection system/Sequential multiport fuel injection system
14	<b>DOME</b>	10	Interior light, Vanity lights, Foot lights, Rear personal light, Gauges and meters, Multi-display
15	<b>ECU-B</b>	7.5	Multiplex computer
16	<b>RAD NO.1</b>	20	Audio system



## ELECTRICAL COMPONENTS

---

No.	FUSE	AMPERE	CIRCUIT
17	H-LP R UPR	15	Right-hand headlight (high beam)
18	H-LP L UPR	15	Left-hand headlight (high beam)
19	A/F HTR	25	Air fuel ratio sensor
20	IGN	7.5	SRS, Multiport fuel injection/Sequential multiport fuel injection system
21	RAD NO.2	7.5	Audio system, Multiplex computer
22	CIG	15	Cigarette lighter, Outside rear view mirrors, Power door lock system
23	D. RR DOOR	20	Rear door lock, Rear power window
24	PWR OUTLET	15	Power outlets
25	FR FOG	15	Fog lights
26	SRS-ACC	15	SRS
27	ECU-IG	15	Telephone, Inside rear view mirror, Anti-lock brake system, Traction control system, Multi-display
28	WIPER	25	Windshield wipers
29	P RR DOOR	20	Rear door lock, Rear power window
No.	FUSE	AMPERE	CIRCUIT

## ELECTRICAL COMPONENTS

30	<b>P FR DOOR</b>	20	Front door lock, Front power window
31	<b>S/ROOF</b>	20	Moon roof
32	<b>HEATER</b>	15	Air conditioning system
33	<b>GAUGE</b>	7.5	Multiplex computer, Service reminder indicators
34	<b>RR WIP</b>	15	Rear window wiper
35	<b>STOP</b>	20	Stop lights, High mounted stoplight, Anti-lock brake system, Traction control system
36	<b>OBD</b>	7.5	On-board diagnosis system
37	<b>SEAT HTR</b>	15	Seat heater system
38	<b>STARTER</b>	7.5	Starting system
39	<b>WASHER</b>	20	Washer
40	<b>RR FOG</b>	7.5	No circuit
41	<b>FR DEF</b>	20	Rear window and outside rear view mirror defogger
42	<b>SRS-B</b>	7.5	SRS
43	<b>TAIL</b>	10	Tail lights, Side marker lights, License plate lights, Parking lights
44	<b>PANEL</b>	7.5	Instrument panel lights
45	<b>ABS</b>	60	Anti-lock brake system
46	<b>ALT</b>	140	Charging system

## **ELECTRICAL COMPONENTS**

---

<b>No.</b>	<b>FUSE</b>	<b>AMPERE</b>	<b>CIRCUIT</b>
47	<b>RDI</b>	<b>40</b>	Cooling fan system
48	<b>CDS</b>	<b>40</b>	Cooling fan system
49	<b>RR DEF</b>	<b>30</b>	Rear window and outside rear view mirror defogger
50	<b>HEATER</b>	<b>50</b>	Blower
51	<b>MAIN</b>	<b>50</b>	Starting system
52	<b>AM1</b>	<b>40</b>	Ignition system
53	<b>POWER</b>	<b>30</b>	Power seats

## CHECKING BATTERY CONDITION

### Precautions



#### CAUTION

##### BATTERY PRECAUTIONS

The battery produces flammable and explosive hydrogen gas.

- Do not cause a spark by contacting the battery terminals with tools.
- Do not smoke or light a match near the battery.

The electrolyte contains poisonous and corrosive sulfuric acid.

- Avoid contact with eyes, skin or clothes.
- Never inhale or swallow electrolyte.
- Wear protective safety glasses when working near the battery.
- Keep children away from the battery.

##### EMERGENCY MEASURES

- If electrolyte gets in your eyes, flush your eyes with clean water for at least 15 minutes and get immediate medical attention. If possible, continue to apply water with a sponge or cloth while traveling to the medical office.

## ELECTRICAL COMPONENTS

---

- If electrolyte gets on your skin, thoroughly wash the contacted area. If you feel a pain or burn, get medical attention immediately.
- If electrolyte gets on your clothes, there is a possibility of its soaking through to your skin, so immediately take off the exposed clothing and follow the procedure above, if necessary.
- If you happen to swallow electrolyte, drink a large quantity of water or milk. Follow with milk of magnesia, beaten raw egg or vegetable oil. Then go immediately for emergency help.

### Checking battery exterior

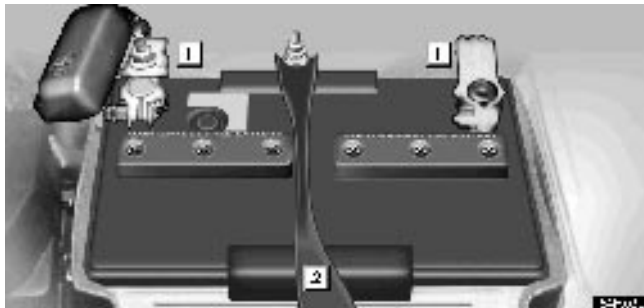

**► 1 Terminals 2 Hold-down clamp**

**Check the battery for corroded or loose connections, cracks, or loose hold-down clamps.**

1. If the battery is corroded, wash it off with a solution of warm water and baking soda. Coat the terminals with grease to prevent further corrosion.
2. If the connections are loose, tighten the clamp bolts – but do not overtighten.
3. Tighten the hold-down clamp only enough to keep the battery firmly in place. Overtightening may damage the battery case.

**NOTICE**

- *Make sure the engine and all accessories are turned off before performing maintenance.*
- *When checking the battery, remove the ground cable first and reinstall it last.*
- *Be careful not to cause a short circuit with tools.*
- *Take care no solution gets into the battery when washing it.*

**Checking battery fluid**

**There are 2 types of batteries: maintenance type and non-maintenance type.**

A non-maintenance battery has "MAINTENANCE FREE BATTERY" on its top. A maintenance type battery does not have such indication.

**Maintenance type battery**

Check the fluid condition by the fluid level lines on the side of the battery. Or if the battery has a hydrometer on its top, you can also check the hydrometer.

**Non-maintenance battery**

Check the battery condition by the hydrometer on the top of the battery.

## ELECTRICAL COMPONENTS

---

(a) Checking by the fluid level lines (Maintenance type battery only)



► **1** Upper line **2** Lower line

(b) **2** Checking by the hydrometer

**The fluid (electrolyte) level must be between the upper and lower lines.**

When checking the fluid level, look at all six cells, not just one or two.

If the level is lower than the lower line, add distilled water. (See "Adding distilled water" on page 448.)



Check the battery condition by the hydrometer color.

**Maintenance type battery**

- 1 RED – Add distilled water. (See "Adding distilled water" on page 448.)
- 2 BLUE – Good condition.
- 3 WHITE – Charging necessary. Have the battery checked by your Lexus dealer.

**Non-maintenance type battery**

- 1 RED – Have the battery checked by your Lexus dealer.
- 2 BLUE – Good condition.
- 3 WHITE – Charging necessary. Have the battery checked by your Lexus dealer.

**NOTICE**

*(For non-maintenance battery):  
Do not refill the battery with water.*



## ELECTRICAL COMPONENTS

---

### Adding distilled water (Maintenance type battery only)

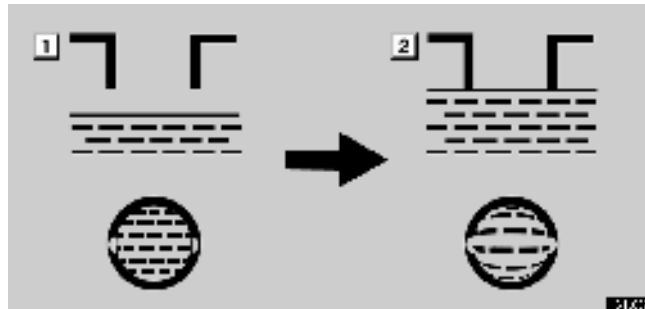

► **1** *Low* **2** *O.K.*

1. Remove the vent plugs.
2. Add distilled water to cells needing fluid.

If the side of your battery is covered, check the water level by looking down directly above the cell as illustrated above.

3. Retighten the vent plugs securely.

#### ***NOTICE***

- *Do not overfill the cells. Excess electrolyte could squirt out of the battery during heavy charging, causing corrosion or damage.*
- *Use a cover on the battery for longer life.*

## BATTERY RECHARGING PRECAUTIONS

**During recharging, the battery is producing hydrogen gas.**

Therefore, before recharging:

1. Maintenance type batteries – Remove the vent plugs.
2. If recharging with the battery installed on the vehicle, be sure to disconnect the ground cable.
3. Make sure the power switch on the recharger is off when connecting the charger cables to the battery and when disconnecting them.



### CAUTION

- **Always charge the battery in an unconfined area. Do not charge the battery in a garage or closed room where there is not sufficient ventilation.**
- **Non-maintenance batteries: Only do a slow charge (5 A or less). Charging at a quicker rate is dangerous. The battery may explode causing personal injuries.**

**Maintenance type batteries: Be sure to remove the vent plugs before recharging.**

## ELECTRICAL COMPONENTS

---

### **NOTICE**

*Never recharge the battery while the engine is running.  
Also, be sure all accessories are turned off.*

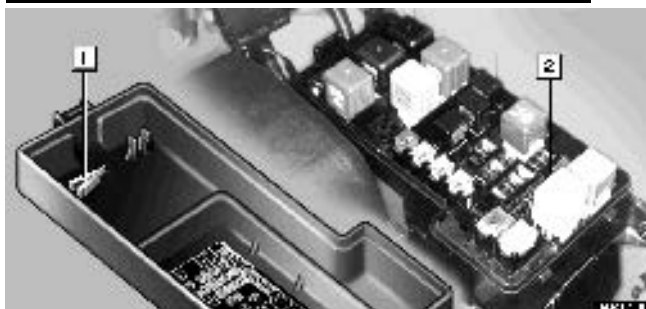

► *Engine compartment* **1** *Pull-out tool* **2** *Spare fuses*

## CHECKING AND REPLACING THE BLADE TYPE FUSES



► *Driver's side instrument panel*

- 1. Turn the ignition switch off and remove the auxiliary box.**

Determine which fuse may be causing the problem. The auxiliary box shows the name of the circuit for each fuse.

## ELECTRICAL COMPONENTS

---

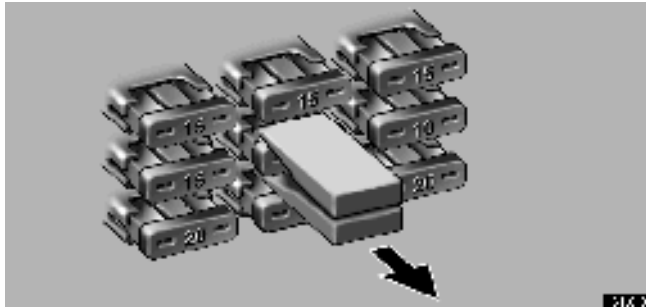

**2. Make sure the inoperative component is turned off. Pull the suspected fuse straight out with the pull-out tool and check it. If it has blown, push a new fuse into the clips.**

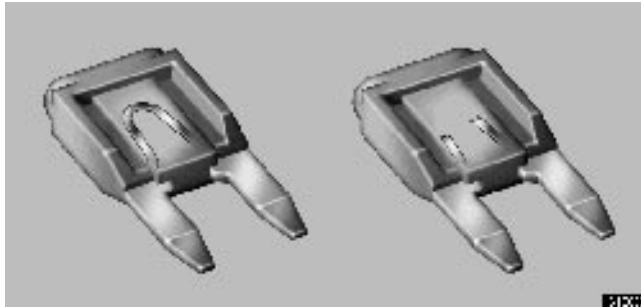

► **Good**

a. Look carefully at the fuse. If the thin wire is broken, the fuse has blown. If you are not sure or if it is too dark to see, try replacing the suspected fuse with one of the same value that you know is good.

b. Only install a fuse with the amperage rating designated on the fuse box lid.

If you do not have a spare fuse, in an emergency you can pull out the "RAD NO.1", "RAD NO.2" or "PWR OUTLET" fuse, which may be dispensable for normal driving, and use it if its amperage rating is the same.

If you cannot use one of the same amperage, use one lower than, but as close as possible to, the amperage. If the amperage is lower than that specified, the fuse might blow out again but this does not indicate anything wrong. Be sure to get the correct fuse as soon as possible and return the substitute to its original clips.

► **Blown**

It is a good idea to purchase a set of spare fuses and keep them in your vehicle for emergencies.

If the new fuse immediately blows out, there is a problem with the electrical system. Have your Lexus dealer correct it as soon as possible.

## ELECTRICAL COMPONENTS

---



### CAUTION

Never use a fuse with a higher amperage rating, or any other object, in place of a fuse. This may cause extensive damage and possibly a fire.

## CHECKING THE CARTRIDGE TYPE FUSES

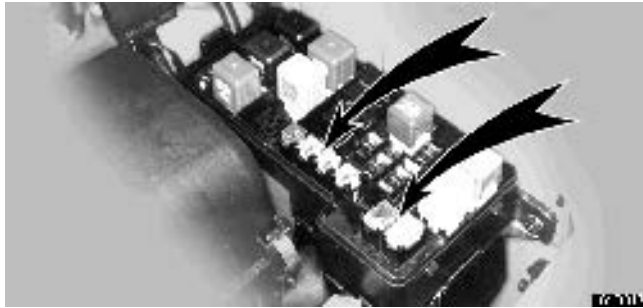

► *Engine compartment*



## ELECTRICAL COMPONENTS

---



### ► *Driver's side instrument panel*

**If the headlights or other electrical components do not work and the blade type fuses are O.K., check the cartridge type fuses. If any of the cartridge type fuses are blown, they must be replaced.**

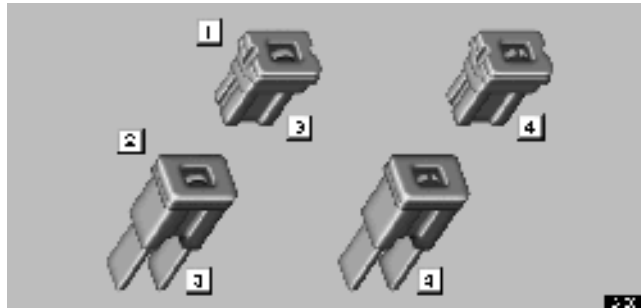

► **1** Type A **2** Type B **3** Good **4** Blown

If there is an overload in the circuits from the battery, the fuses are designed to blow before the entire wiring harness is damaged.

**NOTICE**

*Before replacing the fuses, have the cause of electrical overload determined and repaired by your Lexus dealer.*



**CAUTION**

Always use a genuine Lexus fuse or equivalent for replacement. Never install an ordinary wire – even for a temporary fix. This may cause extensive damage and possibly a fire.

## ELECTRICAL COMPONENTS

---

### ADDING WASHER FLUID



**If the washer tank becomes nearly empty, add washer fluid.**

You may use plain water as washer fluid. However, in cold areas where temperatures range below the freezing point, use washer fluid containing antifreeze. This product is available at your Lexus dealer and most auto parts stores. Follow the manufacturer's directions for how much to mix with water.

#### ***NOTICE***

***Do not use engine antifreeze or any other substitute because it may damage your vehicle's paint.***

### REPLACING LIGHT BULBS

The illustration on the following pages show the locations of light bulbs. If it is necessary to replace a bulb, take your vehicle to your Lexus dealer as soon as possible. Use bulbs with the bulb numbers and wattage ratings given in the table.



**CAUTION**

Halogen bulbs have pressurized gas inside and require special handling. They can burst or shatter if scratched or dropped. Hold a bulb only by its plastic or metal case. Do not touch the glass part of a bulb with bare hands.

**NOTICE**

*Only use a bulb of the listed type.*

**LIGHT LOCATION**

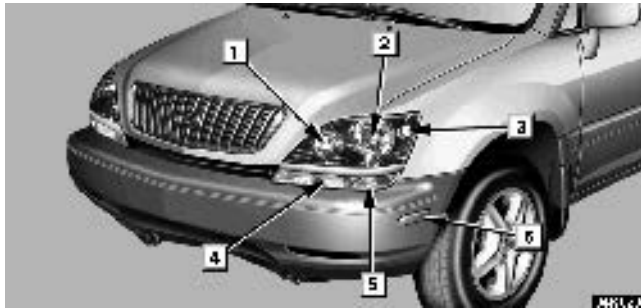

## ELECTRICAL COMPONENTS

---

	Light Bulbs type	Bulb No.	W	T
1	Headlight (high beam) A	9005	60	
2	Headlight B (low and high beam)	9006	51	
3	Parking light C	168	5	
4	Front turn signal D light	W21W	21	
5	Fog light B	9006	51	
6	Front side marker light C	168	5	



**ELECTRICAL COMPONENTS**

Light Bulbs type	Bulb No.	W	T				
				<b>11</b>	Back-up light D	W21W	21
<b>7</b>	High mounted stoplight D	921	18	<b>12</b>	License plate light D	W5W	5
<b>8</b>	Rear turn signal light D	W21W	21				
<b>9</b>	Tail and stop lights D	W21/5W	21/5				
<b>10</b>	Rear side marker light D	W5W	5				

## ELECTRICAL COMPONENTS

---



Light Bulbs type	Bulb No.	W	T			
<b>13</b> Personal light C	—	10		<b>17</b> Glove box light D	—	1.2
<b>14</b> Vanity light E	—	1.5				
<b>15</b> Interior lights E	—	8				
<b>16</b> Door courtesy lights D	—	5				

A: 9005 halogen bulbs  
 B: 9006 halogen bulbs  
 C: Single end bulbs  
 D: Wedge base bulbs  
 E: Double end bulbs

## *SECTION 6 - 5*

---

### **SERVICE PROCEDURES AND SPECIFICATIONS**

#### **Body**

Specifications .....	464
<a href="#">Protecting your vehicle from corrosion</a> .....	465
<a href="#">Washing and waxing</a> .....	466
<a href="#">Cleaning the interior</a> .....	468



## BODY

---

### SPECIFICATIONS

#### – DIMENSIONS AND WEIGHT

Overall length	4575 mm (180.1 in.)
Overall width	1815 mm (71.5 in.)
Overall height	1665 mm (65.6 in.)*
Wheelbase	2615 mm (103 in.)
Tread – Front	1565 mm (61.6 in.)
– Rear	1550 mm (61.0 in.)
Vehicle capacity weight (occupants + luggage)	400 kg (880 lb.)

\*: Unladen vehicle

#### – FUEL TANK

Capacity	65 L (17.2 gal., 14.3 Imp.gal.)
----------	---------------------------------

---

## PROTECTING YOUR VEHICLE FROM CORROSION

Proper care of your Lexus can help ensure long-term corrosion prevention.

**The most common causes of corrosion to your vehicle are:**

- The accumulation of road salt, dirt and moisture in hard-to-reach areas under the vehicle.
- Chipping of paint or undercoating caused by minor accidents or by stones and gravel.

**The following conditions will cause or accelerate corrosion of your vehicle, so it is important to keep your vehicle, particularly the underside, as clean as possible and to repair any damage to paint or protective coatings as soon as possible.**

- The presence of road salt or dust control chemicals, salt in the air near the sea coast, industrial air pollution.
- High humidity, especially at temperatures just above freezing point.
- Certain parts of your vehicle are wet or damp for an extended period of time, even though other parts of the vehicle are dry.
- Components of the vehicle which are prevented from quick-drying due to lack of proper ventilation are exposed to high temperature.

**To help prevent corrosion on your Lexus, follow these guidelines:**

**Keep your vehicle clean by regular washing.** In addition, observe the following points.

- If you drive on salted roads in the winter or if you live near the ocean, you should hose off the undercarriage at least once a month to minimize corrosion.
- High pressure water or steam is effective for cleaning the vehicle's underside and wheel housings. Pay particular attention to these areas as it is difficult to see all the mud and dirt. It will do more harm than good to simply wet the mud and debris without removing them. The lower edge of doors, rocker panels and frame members have drain holes which should not be allowed to clog with dirt as trapped water in these areas can cause corrosion.
- Wash the underside of the vehicle thoroughly when winter is over.

See "Washing and waxing" for more tips.

**Check the condition of your vehicle's paint and trim.** If you find any chips or scratches in the paint, touch them up immediately to prevent corrosion from starting. If the chips or scratches have gone through the bare metal, have a qualified body shop make the repair.

## BODY

---

**Check the interior of your vehicle.** Water and dirt can accumulate under the floor mats and could cause corrosion. Occasionally check under the mats to make sure the area is dry. Be particularly careful when transporting chemicals, cleansers, fertilizers, salt, etc. These should be transported in proper containers. If a spill or leak should occur, immediately clean and dry the area.

**Use mud shields on your wheels.** If you drive on salted or gravel roads, mud shields help protect your vehicle. Full-size shields, which come as near to the ground as possible, are the best. We recommend that the fittings and the area where the shields are installed be treated to resist corrosion. Your Lexus dealer will be happy to assist in supplying and installing the shields if they are recommended for your area.

**Keep your vehicle in a well ventilated garage or a roofed place. Do not park your vehicle in a damp, poorly ventilated garage.** If you wash your vehicle in the garage, or if you drive it in covered with water or snow, your garage may be so damp it will cause corrosion. Even if your garage is heated, a wet vehicle can corrode if the ventilation is poor.

## WASHING AND WAXING

### Washing your Lexus

**Keep your vehicle clean by regular washing.**

The following cases may cause weakness to the paint or corrosion to the body and parts. Wash your vehicle as soon as possible.

- When driving in a coastal area
- When driving on a road sprinkled with antifreeze
- When having stuck of coal tar, tree sap, bird droppings and carcass of an insect
- When driving in the areas where there is a lot of smoke, soot, dust, iron dust and chemical substance
- When the vehicle becomes remarkably dirty with dust and mud

### Hand-washing your Lexus

**Work in the shade and wait until the vehicle body is not hot to the touch.**

1. Rinse off loose dirt with a hose. Remove any mud or road salt from the underside of the vehicle or in the wheel wells.

2. Wash with a mild car-wash soap, mixed according to the manufacturer's instructions. Use a soft cotton mitt and keep it wet by dipping it frequently into the wash water. Do not rub hard – let the soap and water remove the dirt.

**Aluminum wheels:** Use only a mild soap or neutral detergent.

**Urethane bumpers and side moldings:** Wash carefully. Do not scrub with abrasive cleaners. The bumper and side molding faces are soft.

**Road tar:** Remove with turpentine or cleaners that are marked safe for painted surfaces.

***NOTICE***

*Do not use gasoline or strong solvents, which may be toxic or cause damage.*

3. Rinse thoroughly – dried soap can cause streaking. In hot weather you may need to rinse each section right after you wash it.

4. To prevent water spots, dry the vehicle using a clean soft cotton towel. Do not rub or press hard – you might scratch the paint.

### Automatic car wash

***NOTICE***

*To prevent damage to the antenna, make sure it is retracted before driving your vehicle through an automatic car wash.*

Your vehicle may be washed in an automatic car wash, but remember that the paint can be scratched by some type of brushes, unfiltered washing water, or the washing process itself. Scratching reduces paint durability and gloss, especially on darker colors. The manager of the car wash should be able to advise you whether the process is safe for the paint on your vehicle.

### Waxing your Lexus

**Polishing and waxing is recommended to maintain the original beauty of your Lexus' finish.**

Once a month or if the vehicle does not repel water well, apply wax.

1. Always wash and dry the vehicle before you begin waxing, even if you are using a combined cleaner and wax.

2. Use a good quality polish and wax. If the finish has become extremely weathered, use a car-cleaning polish, followed by a separate wax. Carefully follow the manufacturer's instructions and precautions. Be sure to polish and wax the chrome trim as well as the paint.

## BODY

---

3. Wax the vehicle again when water does not bead but remains on the surface in large patches.

## CLEANING THE INTERIOR



### CAUTION

- **Be careful not to splash water or spill liquid on the floor. This may prevent the side airbags from activating correctly, resulting in serious injury.**
- **Do not wash the vehicle floor with water, or allow water to get onto the floor when cleaning the vehicle interior or exterior. Water may get into audio components or other electrical components above or under the floor carpet (or mat) and cause a malfunction; and it may cause body corrosion.**

### Leather Interior

The selected leather is used in your Lexus. Due to a leather product, some parts of leather may be rough, uneven or scratched originally.

To keep good appearance, we recommend you to clean it periodically twice a year.

Remove dirt on the leather in the following ways:

1. Wipe it off lightly using a soft cloth (e.g. gauze) dampened with 5% solution of neutral detergent for wool.
2. Wring water from a clean cloth and thoroughly wipe off all traces of detergent with it.
3. Wipe off the surface of the leather with a dry soft cloth. Allow the leather to dry in a ventilated shaded area. Excess of wet may cause the hardening or shrinking of the leather.

#### **NOTICE**

- *Dirt or sand adhered to the leather may damage the treated surface and cause it to wear earlier. Remove dirt or sand using a vacuum cleaner.*
- *If a stain should fail to come out with a neutral detergent, apply a cleaner that does not contain an organic solvent.*
- *Never use organic substances such as benzine, alcohol or gasoline, or alkaline or acid solutions for cleaning the leather as these could cause discoloring.*
- *Use of a nylon brush or synthetic fiber cloth, etc. may scratch the fine grained surface of the leather.*
- *Mildew may develop on soiled leather upholstery. Be especially careful to avoid oil spots. Try to keep your upholstery always clean.*
- *Long exposure to direct sunlight may cause the leather surface to harden and shrink. Keep your vehicle in a shaded area, especially in the summer.*
- *The interior of your vehicle is apt to heat up on hot summer days, so avoid placing on the upholstery items made of vinyl or plastic or containing wax as these tend to stick to leather when warm.*
- *Improper cleaning of the leather upholstery could result in discoloration or staining.*

## BODY

---

### Synthetic Leather Areas (Dash)

**The synthetic leather areas may be easily cleaned with a mild soap or detergent and water.**

First vacuum over the upholstery to remove loose dirt. Then, using a sponge or soft cloth, apply the soap solution to the synthetic leather. After allowing it to soak in for a few minutes to loosen the dirt, remove the dirt and wipe off the soap with a clean damp cloth. If all the dirt does not come off, repeat the procedure. Commercial foaming-type cleaners are also available which work well. Follow the manufacturer's instructions.

#### ***NOTICE***

***Do not use solvent, thinner, gasoline or window cleaner on the interior.***

### Carpets, Windows and Seat Belts

Begin by vacuuming thoroughly to remove as much dirt as possible. Several types of foam cleaners are available; some are in aerosol cans and others are powders or liquids which you mix with water to produce a foam. To shampoo the carpets, use a sponge or brush to apply the foam. Rub in overlapping circles. Do not apply water – the best results are obtained by keeping the carpet as dry as possible. Read the shampoo instructions and follow them closely.

**The seat belts may be cleaned with mild soap and water or with lukewarm water.**

Use a cloth or sponge. As you are cleaning, check the belts for excessive wear, fraying or cuts.

#### ***NOTICE***

- ***Use a good foam-type shampoo to clean the carpets.***
- ***Do not use dye or bleach on the belts – it may weaken them.***
- ***Do not use the belts until they become dry.***
- ***The windows may be cleaned with any household window cleaner.***
- ***When cleaning the inside of the rear window, be careful not to scratch or damage the heater wires.***

**Air Conditioning Control Panel, Car Audio,  
Instrument Panel, Console Panel, and  
Switches**

Use a soft damp cloth for cleaning.

Soak a clean soft cloth in water or lukewarm water then lightly wipe off any dirt.

***NOTICE***

- *Do not use organic substances (solvents, kerosene, alcohol, gasoline, etc.) or alkaline or acidic solutions. These chemicals can cause discoloring, staining or peeling of the surface.*
- *If you use cleaners or polishing agents, make sure their ingredients do not include the substances mentioned above.*
- *If you use a liquid car freshener, do not spill the liquid onto the vehicle's interior surfaces. It may contain the ingredients mentioned above. Immediately clean any spill using the method mentioned above.*

**If you have any questions about the cleaning of your Lexus, your local Lexus dealer will be pleased to answer them.**



# *SECTION 7*

---

## **REPORTING SAFETY DEFECTS FOR U.S. OWNERS**

[Reporting safety defects for U.S. owners](#) .....  
473

## **REPORTING SAFETY DEFECTS FOR U.S. OWNERS**

If you believe that your vehicle has a defect which could cause a crash or could cause injury or death, you should immediately inform the National Highway Traffic Safety Administration (NHTSA) in addition to notifying Toyota Motor Sales, U.S.A., Inc. (Toll-free: 1-800-25-LEXUS).

If NHTSA receives similar complaints, it may open an investigation, and if it finds that a safety defect exists in a group of vehicles, it may order a recall and remedy campaign. However, NHTSA cannot become involved in individual problems between you, your dealer, or Toyota Motor Sales, U.S.A., Inc.

To contact NHTSA, you may either call the Auto Safety Hotline toll-free at 1-800-424-9393 (or 366-0123 in Washington.D.C. area) or write to: NHTSA, U.S. Department of Transportation, Washington. D.C. 20590. You can also obtain other information about motor vehicle safety from the Hotline.